

THE EVOLUTION OF INCOME INEQUALITY IN THE EUROPEAN UNION

Autores: *Santiago Álvarez García*^(a)
Juan Prieto Rodríguez^(b)
Rafael Salas^(c)

P. T. N.º 10/02

(a) Instituto de Estudios Fiscales y Universidad de Oviedo.

(b) Instituto de Estudios Fiscales y Universidad de Oviedo.

(c) Instituto de Estudios Fiscales y Universidad Complutense de Madrid.

Address for correspondence: Santiago Álvarez-García, Instituto de Estudios Fiscales. Cardenal Herrera Oria, 378. 28035 Madrid.

E-mail & telephone number: santiago.alvarez@ief.minhac.es (+ 34-91-339-8744).

N.B.: Las opiniones expresadas en este trabajo son de la exclusiva responsabilidad de los autores, pudiendo no coincidir con las del Instituto de Estudios Fiscales.

Desde el año 1998, la colección de Papeles de Trabajo del Instituto de Estudios Fiscales está disponible en versión electrónica, en la dirección: ><http://www.minhac.es/ief/principal.htm>.

Edita: Instituto de Estudios Fiscales
N.I.P.O.: 111-02-004-2
I.S.S.N.: 1578-0252
Depósito Legal: M-23772-2001

ÍNDICE

- I. INTRODUCTION
 2. THE MEASUREMENT OF INCOME INEQUALITY
 3. EMPIRICAL RESULTS
 - 3.1. Data
 - 3.2. General overview
 - 3.3. Robust within-countries inequality comparisons
 - 3.4. Evolution of between-countries equality (convergence)
 4. CONCLUSIONS
- APPENDIX
- REFERENCES

ABSTRACT

The objective of this work is to analyse the income inequality in the 15 EU countries during the convergence process to the Monetary Union. Using the information contained in the European Community Household Panel, corresponding to the four first waves. Using the inverse second order stochastic dominance concept, we have carried out an ordering of these countries. Furthermore, this ranking allows us to determine if the differences among EU country members have increased or decreased during this particular period, that is, if there was a real convergence in income equality. In addition, we have also studied whether the inequality of income has diminished within and between countries over time. Gini's generalised family indices proposed by Donaldson and Weymark (1980 and 1983) and Yitzhaki (1983) have been used. This allows us to test the sensitivity of the results obtained to different degrees of inequality aversion and to different equivalence scales, taking into account household sizes.

EL codex: D31, D63, F02, O52

Key words: Inequality, European Union, income distribution, stochastic dominance.

RESUMEN

El objetivo de este trabajo es el análisis de la desigualdad en la distribución de la renta en los países de la UE durante el proceso de convergencia a la moneda única. Mediante el empleo de la información contenida en el Panel de Hogares de la Unión Europea (PHOGUE) en las olas 1994-97 se realiza una ordenación de los 15 países analizados en función de su grado de desigualdad. Esta ordenación, atendiendo al concepto de dominancia estocástica inversa de segundo orden, permite determinar si la desigualdad en las distribuciones de renta de los distintos países se ha aproximado a lo largo de este periodo tan especial, es decir, si se ha producido una convergencia real en la igualdad de la distribución de rentas. Asimismo se analiza la evolución temporal de la desigualdad de la renta dentro de cada país.

Para realizar este trabajo se ha utilizado la familia de índices de Gini generalizada propuesta por Donaldson y Weimark (1980 y 1983) y Yitzaki (1983). Esto ha permitido contrastar la sensibilidad de los resultado obtenidos para distintos grados de aversión a la desigualdad y escalas de renta equivalente entre hogares de tamaño y composición diferente.

Códigos JEL: D31, D63, F02,O52.

Palabras Clave: Desigualdad, Unión Europea, distribución de rentas, políticas redistributivas, dominancia estocástica.

1. INTRODUCTION

The main objective of this paper is to analyse the inequality in the income distribution in the UE country members in the period 1993-1996. This period coincides with the convergence process to the Monetary Union. Using the second-order inverse stochastic dominance concept, we have carried out a robust ordering of these countries according to the inequality ranking. Furthermore, this ranking allows us to determine if the differences among the inequality within the EU country members have increased or decreased during this period. Hence, we can test whether or not there has been a real convergence in income equality in this crucial period.

Besides, the temporary evolution of income inequality has been also analysed within each country. Finally, we explore whether there has been a process of real income convergence among the EU countries themselves, by checking the evolution of the between-countries income inequality in this period.

To achieve these goals, the S-Gini generalised family indices proposed by Donaldson and Weymark (1980 and 1983) and Yitzhaki (1983) together with a parametric form for the equivalence scales [Coulter *et al* (1992)] have been used. This has enabled us to test the sensitivity of the results to different degrees of inequality aversion and to different equivalence scales, taking into account household sizes and composition.

We have used the information contained in the European Community Household Panel (ECHP). This survey contains data on individuals and households for fifteen European countries, with four waves currently available (1994-1997). The information is homogenous across countries, as the questionnaire is similar and the elaboration process of the survey is co-ordinated by EUROSTAT. Hence, this database has the advantage that the methodology is common to all the countries analysed, making comparisons reliable.

2. The measurement of income inequality

We are going to present the following framework, where we can analyse inequality evolution in a robust way. To do so we build up a setting in which we can make sensitivity analysis with respect to the inequality index and to the equivalence scale. A very natural way to do so is to use a class of parametric equivalence scales as in Coulter *et al.* (1992) and to compute the extended S-Gini coefficients proposed by Kakwani (1980), Donaldson and Weymark (1980, 1983) and Yitzhaki (1983) and defined as:

$$G(v) = 1 - v(v-1) \int_0^1 (1-p)^{v-2} L(p) dp \quad v > 1$$

where $L(p)$ is the Lorenz curve for any percentile p , and v is the normative inequality aversion parameter. Note that for $v = 2$, we obtain the Gini standard coefficient.

Muliere and Scarcini (1989) perceived an important dominance property of this class of indices. Given two distributions A and B with the same means, if a distribution A inverse stochastic dominates B at order n , then $G_A(v) \leq G_B(v)$ for any $v \geq n - 1$ ¹.

Definition: A distribution A dominates B according to $G(v)$ for $v \in [v^*, v^{**}]$, denoted as $\geq_G^{v^*, v^{**}} B$, if and only if $G_A(v) \leq G_B(v)$ for all $v \in [v^*, v^{**}]$. We are going to check on this property for all computable $G(v)$ indices across countries.

Definition of *relative inverse stochastic dominance* RISD criterion: Given two distributions A and B defined on a non-negative random variable X with finite expectation. The distribution A *n-degree relative indirect stochastic dominates* B , and we will write $A \succ_{\text{RISD}}^n B$, for any integer $n \geq 1$, if and only if $\tilde{A} \succ_{\text{ISD}}^n \tilde{B}$, where \tilde{A} and \tilde{B} are the distributions A and B normalised by their means $\mu(A)$ and $\mu(B)$, respectively.

An important property arises. Given two distributions A and B , with different means, if a distribution A relative inverse stochastic dominates B at order n , then $G_A(v) \leq G_B(v)$ for any $v \geq n - 1$.

3. EMPIRICAL RESULTS

3.1. Data

In this section, computing the indices presented above, we analyse income inequality across EU countries using the ECHP panel. Given the nature of our study, we have mainly used household information and the size of sample varies

¹ Inverse n -degree stochastic dominance introduced by Muliere and Scarsini (1989) has appealing properties in terms of consistency with very general class of the Yaari rank-dependent Social Welfare Functions. See for instance Zoli (1999) and Aaberge (2001) theorems on *n-degree inverse stochastic (welfare) dominance*. Given two distributions F and G defined over a non-negative random variable X with finite expectations. The distribution F *n-degree indirect stochastic dominates* G , denoted as $F \succ_{\text{ISD}}^n G$, for any integer $n \geq 1$, if and only if $F_n^{-1}(p) \leq G_n^{-1}(p)$ for all $p \in [0,1]$. Define $F_n^{-1}(p)$ as the n -th *degree inverse distribution function*, for $n = 1$, as:

$$F_1^{-1}(p) = F^{-1}(p) = \inf\{X : F(X) \geq p\} \quad p \in [0,1]$$

and for $n \in \{2,3,\dots\}$ as:

$$F_n^{-1}(p) = \int_0^p F_{n-1}^{-1}(u) du \quad p \in [0,1]$$

across countries and along the waves. Actually, Austria, Finland and Sweden were not present in the first wave (ECHP-94), which contains information on 1993 income. Moreover, Luxembourg was not included in the sample in wave fourth (ECHP-97) with 1996 income information. The households' sample composition for each country and each year is presented in Table A1, provided in the Appendix.

Nevertheless, the ECHP is a very rich source of information and, for every household, it provides information on personal characteristics of all members older than 16 years old (age, education, work experience, personal income, etc.) and information on household structure, sources of household income (referred to the previous year), number of small children, accommodation, etc.

In the next sections, we describe the main results that we obtain using this survey.

3.2. General overview

In this subsection, we present a general overview of the results on income inequality in the European Union countries during the convergence to the Monetary Union process (1993-96). Since we want to give a robust answer to what happened with income distributions during these four years, we have computed different S-Gini coefficients, instead of drawing a conclusion based only on one arbitrary inequality index. Besides, we have made comparisons across countries and, simultaneously, along the four available waves of the ECHP data set. Furthermore, we have computed population-weighted between-groups S-Gini indices to test spatial convergence across countries during this period.

We have checked the dominance properties of these comparisons for the S-Gini ranking ν from 1.5 to 7. This can be interpreted in terms of more robust conclusions in our analysis. Most of the relevant indices used in the literature are somehow connected to these dominance properties.

The main propose when testing this dominance properties was reached by ranking the countries according to the S-Gini coefficients from ν equal to 1.5 to ν equal to 7.0, in order to compare the different degrees of income inequality². At the same time, we have tried to analyse the sensitivity of the inequality ranking to the equivalence scales. To achieve this goal, we have divided the household income by an adult-equivalent scale h^α [Coulter *et al.* (1992)], where h is the household size and α ranks from zero to one. Parameter α can be interpreted as a measure of economies of scales within the household. All observations are weighted according to the number of persons in the household.

² For values of ν higher than 7, large-sample countries exhibit computational problems since the algorithm tend to infinity.



In Table 1 we present the Gini standard coefficient ($v = 2$) for α equal to 0.5 for all the countries with at least three observations in our sample³. Broadly speaking, we can classify countries into five different groups according to the income inequality. Sorted in ascending order with respect to the Gini inequality coefficients, Denmark is the first group in the ranking: no other country presents a lower Gini coefficient during this period and it remains the most income equitable country. The second group is composed of The Netherlands, Germany, Austria and Luxembourg: they have swapped their positions in the inequality ranking among them. UK, Ireland, Belgium, France, Italy and Spain constitute the third group, meanwhile Greece and Portugal are the fourth and fifth groups since they remain the most inequitable countries.

Last column in Table 1 shows the trend observed for each country income inequality. We have observed a tendency to increase Gini inequality during the period in Denmark, The Netherlands, UK and Ireland, and a tendency to reduce inequality in Portugal, Germany, Austria Luxembourg, France, Italy, Belgium and Greece. Spain seems to remain unchanged over the period.

Table 1
EQUALITY RANKINGS
(according to Gini coefficient, $\alpha = 0.5$)

Ranking 1993		Ranking 1996		Inequality Trend
1	Denmark	1	Denmark	(+)
2	Netherlands	2	Germany	(--)
3	Germany	3	Austria**	(--)
4	Austria**	4	Netherlands	(+)
5	Luxembourg*	5	Luxembourg*	(--)
6	UK	6	France	(-)
7	Ireland	7	Italy	(-)
8	Italy	8	Belgium	(-)
9	France	9	UK	(+)
10	Spain	10	Ireland	(+ +)
11	Belgium	11	Spain	(=)
12	Greece	12	Greece	(-)
13	Portugal	13	Portugal	(--)

Luxembourg*, 1993-1995.

Austria**, 1994-1996.

³ Hence, Finland and Sweden are not included since they are observed only twice and once respectively.

The aim of the rest of this paper is to check the robustness of these results by computing the values for different v and α . In the following sections we analyse first the difference in the inequalities among countries for each period. Then, we proceed to study the difference in inequality for each country along the whole period. Finally, we explore the convergence process in real equivalent income among countries, by studying the between-groups inequality indices in the period.

3.3. Robust within-countries inequality comparisons

Starting from the computed indices, we have carried out a ranking of inequality in the income distribution, based on the dominance properties for the S-Gini index. This ranking, for each year, is presented graphically in Figure 1. Dotted lines delimit countries with lower values of the Gini indices only for some values of v , but not for all of them. This means that it is impossible to establish a stochastically dominating ranking among this set of countries; that is to say, they are non-comparable according to this criterion. Obviously, the ranking is not constant over time and some important differences can be observed comparing different years. However, four substantial groups of European Union countries can be detected. A first group would be composed of Denmark, Sweden and Finland, that is, those countries with the smallest degree of inequality. A second group would be formed by Germany, Austria, the Netherlands and France. This group of intermediate inequality countries included Luxembourg until 1995, last year in which it appears in the Panel. Belgium, United Kingdom, Italy, Ireland and Spain would constitute the third group, with a higher inequality degree than the two previous sets of countries. Finally, Greece and Portugal present the highest degree of inequality in the income distribution and could be considered the elements of the fourth and last set of countries.

Since Figure 1 displays inequality rankings using equivalence scales computed with α equal to 0.5, furthermore we wish to analyse the influence that different equivalence scales could have on these results. In order to do this, in Figure 2 we represent inequality rankings in 1996-income distribution, using three different equivalence scales. The main conclusion of this figure is the robustness of the results, since we did not observe significant variations when changing the equivalence scale. Indeed, there are only two minor differences. On the one hand, if we increase α from 0.5 to 0.75, Greece stop being dominated by Ireland and, hence, it enlarges Belgium, UK, Spain, Italy and Ireland group. On the other hand, when we decrease α from 0.5 to 0.25, Finland stop being dominated by Denmark and, at the same time, the Netherlands gets dominated by Austria and Germany.

Moreover, Figures 3 to 6 display the dominance analysis of inequality evolution inside each country. According to these figures, we can, again, distinguish four groups. A first set of countries where inequality has monotonically de-



creased during the whole period in an unequivocal way, since this result does not depend on the equivalence scale or the elected v . This group is formed by Germany, Luxembourg, Portugal and Austria and it is represented in Figure 3.

A second set of countries, outlined by Figure 4, is composed of Belgium, Italy, France and Greece. This group is characterised by a decrease in income inequality with regard to the initial situation (year 1993). However, this result is not conclusive as it is for the previous set of countries, since the improvement in the income distribution has mainly taken place until 1995, these countries presenting a probable increase in inequality in 1996.

A third group of countries (Denmark, United Kingdom and Spain) is involved in an ambiguous change in inequality during the analysed period, as can be observed in Figure 5. For instance, Danish income distribution has been more equitable during 1993 and 1994 but 1996 is not dominated by 1993 for α equal or greater than 0.5, meaning that these two distributions are not comparable and that is not possible to make any settlement about them. Moreover, United Kingdom 1995 income distribution dominates the other three years distributions (for any α) but 1993 and 1996 are not directly comparable. The Spanish case is more complex since the lowest inequality level takes place in 1994, but we get different results for the three other years, depending on the equivalence scale. For α lower or equal to 0.5, 1996 income dominates 1995 and 1993 income distributions, while for α equal to 0.75 they are not comparable.

Finally, Ireland and the Netherlands present a non-monotonically increment in income inequality during this period, as it is shown in Figure 6, and they represent the fourth set of countries.

3.4. Evolution of between-countries equality (convergence)

We have studied the evolution of the between-countries income inequality existing in this period in order to explore whether there has been a process of real income convergence among the EU countries (Salas, 2002). We have used the exchange rates as a homogenisation criterion to compare income levels in the different countries.

To do this, we compute population-weighted between-groups S-Gini inequality indices for the eleven countries that have been present in all the periods (four waves) in the ECHP. Two important issues arise. First, the population of a country is taken into consideration in the weights of the indices and second, equivalence scales are considered when computing the equivalent income. The latter point suggests that more robust analysis can be made, in comparison with the usual aggregate-based per capita convergence studies, since changes in the equivalent scale can be implemented. Traditional per capita results coincide with the particular $\alpha = 1$ case. All the computed indices are displayed in Table 2.

Table 2
BETWEEN-COUNTRIES INCOME INEQUALITY

	a=0.25				a=0.50				a=0.75				a= 1			
	1993	1994	1995	1996	1993	1994	1995	1996	1993	1994	1995	1996	1993	1994	1995	1996
v=1.5	0.2314	0.2177	0.2309	0.2159	0.2298	0.2209	0.2344	0.2212	0.2344	0.2259	0.2394	0.2264	0.2408	0.2308	0.2434	0.2315
v=2	0.3092	0.3023	0.3203	0.3018	0.3193	0.3104	0.3283	0.3102	0.3294	0.3184	0.3363	0.3185	0.3393	0.3261	0.3441	0.3265
v=3	0.3962	0.3942	0.4129	0.3922	0.4135	0.4062	0.4237	0.4044	0.4277	0.4180	0.4353	0.4165	0.4415	0.4293	0.4497	0.4281
v=4	0.4616	0.4605	0.4765	0.4565	0.4791	0.4744	0.4883	0.4707	0.4951	0.4881	0.5017	0.4846	0.5107	0.5013	0.5192	0.4981
v=5	0.5116	0.5116	0.5242	0.5055	0.5289	0.5263	0.5363	0.5205	0.5454	0.5407	0.5504	0.5353	0.5616	0.5547	0.5682	0.5496
v=6	0.5500	0.5509	0.5602	0.5428	0.5668	0.5657	0.5722	0.5581	0.5833	0.5802	0.5865	0.5731	0.5994	0.5943	0.6033	0.5876
v=7	0.5799	0.5815	0.5878	0.5717	0.5963	0.5961	0.5997	0.5868	0.6124	0.6104	0.6139	0.6017	0.6281	0.6242	0.6294	0.6160



We have summarised Table 2 information contained in Figure 7. As it can be observed in this graphic analysis of income dominance, between-countries income inequality has decreased during this period since 1996 income distribution is not dominated by other years distributions and it strictly dominates 1993 income distribution. This implies that there has been a convergence in real income during these years. This result can be considered more robust than the usual aggregate-based per capita convergence since this measure is based on the actual household structure and it takes into account the equivalence scales.

4. CONCLUSIONS

Using the generalised family of Gini indices proposed by Donaldson and Weymark (1980 and 1983) and Yitzhaki (1983) we have analysed the income inequality across EU countries. The main propose of computing this indices was to check the dominance properties for the S-Gini (ranking v from 1.5 to 7), in order to classify the countries according to income inequality. This can be interpreted in terms of more robust conclusions in our analysis. At the same time, we have tried to analyse the sensitivity of this inequality ranking to the equivalence scales. To achieve this goal, we have divided the household income by an adult-equivalent scale h^α . We have taken α values ranking from 0.25 to 0.75.

To carry out this analysis, we have used the information contained in the European Community Household Panel (ECHP) and we have found that countries can be classified into four different groups. A first group would be composed of Denmark, Sweden and Finland, that is, those countries with the smallest degree of inequality. Germany, Austria, the Netherlands and France would form a second group. This group of intermediate inequality countries included Luxembourg till 1995, the last year in which it appears in the Panel. Belgium, United Kingdom, Italy, Ireland and Spain constitute a third group, with a higher inequality degree. Finally, Greece and Portugal are the elements of the fourth and last set of countries and they have the highest degree of inequality in the income distribution.

Furthermore, we have detected that differences among inequality within the EU country members have been reduced during this period, that is we found a real convergence in income equality during this period. Even more, the temporary evolution of income inequality within each country has been also analysed finding that there is not a unique pattern to describe it. However, more than a half of the counties in our sample have experienced an increase in their income equality and only two have increased their inequality during this period.

Finally, we have studied the evolution of the between-countries income inequality in this period in order to explore whether there has been a process of real income convergence among the EU countries. We have used the exchange rates as a homogenisation criterion to compare income levels of different countries and we found that between-countries income inequality has decreased. This implies that there has been a convergence in real income during these years; along with the convergence process in income equality pointed out above. This result can be considered more robust than the usual aggregate-based per capita convergence since this measure is based on the actual household structure and it takes into account the equivalence scales.

APPENDIX

Table A1
HOUSEHOLDS' SAMPLE COMPOSITION IN THE ECHP (94-97)

Households' composition											
	Years	1 member	2 members	3 members	4 members	5 members	6 members	7 members	More than 7 members	Number of households	Number of individuals
Denmark	1993	1212	1170	461	484	115	34	5	1	3482	7693
	1994	1104	1075	435	449	123	30	6	1	3223	7200
	1995	1035	969	401	401	115	26	7	1	2955	6568
	1996	921	915	382	379	107	32	8	1	2745	6204
The Netherlands	1993	1326	1794	699	942	337	67	18	4	5187	13029
	1994	1319	1749	717	918	321	67	14	5	5110	12791
	1995	1370	1773	687	929	331	76	11	2	5179	12897
	1996	1299	1778	657	915	319	68	10	3	5049	12584
Belgium	1993	841	1037	662	625	237	63	18	7	3490	9149
	1994	828	982	628	601	240	63	15	9	3366	8839
	1995	794	960	572	577	221	62	13	11	3210	8398
	1996	762	918	525	548	204	57	14	11	3039	7916
Luxembourg	1993	228	275	184	192	97	24	8	3	1011	2087
	1994	210	271	170	190	87	25	7	2	962	2672
	1995	205	259	168	181	90	23	5	2	933	2590

(Sigue)

(Continuación)

Households' composition											
	Years	1 member	2 members	3 members	4 members	5 members	6 members	7 members	More than 7 members	Number of households	Number of individuals
France	1993	1911	2277	1231	1219	483	159	30	34	7344	18916
	1994	1690	2092	1191	1093	462	135	30	29	6722	17408
	1995	1665	2094	1142	1077	434	135	29	24	6600	16985
	1996	1594	1971	1053	981	412	113	31	21	6176	15758
Ireland	1993	532	873	644	765	627	325	138	144	4048	14585
	1994	501	818	543	708	514	270	132	98	3584	12577
	1995	475	739	504	592	450	234	96	83	3173	10887
	1996	453	707	476	531	415	210	83	70	2945	9952
Italy	1993	1047	1525	1717	1847	683	220	55	21	7115	21934
	1994	1060	1591	1717	1809	680	197	56	18	7128	21757
	1995	1101	1622	1730	1771	661	178	51	18	7132	21506
	1996	1045	1567	1655	1624	597	154	54	17	6713	20074
Greece	1993	911	1485	1069	1383	426	184	54	11	5523	16321
	1994	863	1442	1033	1257	394	166	53	12	5220	15309
	1995	827	1325	973	1196	384	145	46	11	4907	14384
	1996	751	1271	955	1073	358	138	45	13	4604	13491
Spain	1993	1004	1670	1484	1764	811	305	104	64	7206	23025
	1994	924	1539	1332	1588	717	270	104	48	6522	20708
	1995	873	1550	1284	1510	670	246	89	45	6267	19712
	1996	802	1435	1213	1398	612	219	70	45	5794	18167

(Sigue)

(Continuación)

Households' composition											
	Years	1 member	2 members	3 members	4 members	5 members	6 members	7 members	More than 7 members	Number of households	Number of individuals
Portugal	1993	762	1338	1079	1007	403	178	55	59	4881	14706
	1994	763	1352	1097	995	404	184	59	62	4916	14826
	1995	739	1328	1119	985	384	172	56	67	4850	14627
	1996	740	1318	1104	980	382	154	63	61	4802	14428
Germany	1993	1333	1963	1330	1092	355	85	32	17	6207	16284
	1994	1355	1989	1334	1164	356	85	36	17	6336	16682
	1995	1375	1999	1285	1133	335	83	34	15	6259	16304
	1996	1345	2035	1239	1101	326	73	30	14	6163	15942
UK	1993	1335	1665	901	802	313	78	25	7	5126	12844
	1994	1312	1690	866	753	307	71	24	9	5032	12508
	1995	1272	1699	855	775	303	69	25	13	5011	12547
	1996	1241	1704	855	774	295	73	16	7	4965	12397
Austria	1994	731	1008	559	599	275	123	53	32	3380	9579
	1995	725	985	538	588	266	113	46	30	3291	9248
	1996	708	944	511	575	231	105	45	23	3142	8733
Finland	1995	851	1343	743	754	323	87	29	9	4139	11214
	1996	941	1321	713	696	311	88	26	12	4108	10890
Sweden	1996	1957	2000	750	810	277	71	17	9	5891	13453

Table A2
INEQUALITY S-GINI INDICES ($v = 2.0$) FOR DIFFERENT EQUIVALENCE SCALES

Years	Gini $v = 2.0$ $\alpha = 0.25$				Gini $v = 2.0$ $\alpha = 0.50$				Gini $v = 2.0$ $\alpha = 0.75$			
	1993	1994	1995	1996	1993	1994	1995	1996	1993	1994	1995	1996
Germany	0.2717	0.2700	0.2646	0.2561	0.2735	0.2684	0.2636	0.2544	0.2899	0.2807	0.2764	0.2671
Austria	n.a.	0.2857	0.2754	0.2652	n.a.	0.2786	0.2670	0.2570	n.a.	0.2877	0.2749	0.2655
Belgium	0.3441	0.3379	0.3132	0.3155	0.3407	0.3315	0.3078	0.3079	0.3486	0.3371	0.3156	0.3134
Denmark	0.2286	0.2310	0.2399	0.2383	0.2143	0.2156	0.2231	0.2226	0.2176	0.2173	0.2232	0.2251
Spain	0.3444	0.3345	0.3444	0.3471	0.3396	0.3278	0.3387	0.3402	0.3433	0.3303	0.3419	0.3417
Finland	n.a.	n.a.	0.2398	0.2446	n.a.	n.a.	0.2329	0.2365	n.a.	n.a.	0.2413	0.2444
France	0.3328	0.2884	0.2867	0.2906	0.3299	0.2852	0.2818	0.2851	0.3392	0.2947	0.2898	0.2931
Greece	0.3695	0.3533	0.3430	0.3550	0.3656	0.3476	0.3391	0.3497	0.3685	0.3491	0.3429	0.3515
The Netherlands	0.2479	0.2703	0.2741	0.2593	0.2526	0.2746	0.2782	0.2624	0.2715	0.2929	0.2962	0.2801
Ireland	0.3175	0.3259	0.3388	0.3330	0.3127	0.3216	0.3346	0.3290	0.3191	0.3277	0.3404	0.3352
Italy	0.3282	0.3191	0.3069	0.3093	0.3275	0.3165	0.3061	0.3068	0.3353	0.3228	0.3145	0.3135
Luxembourg	0.3054	0.2829	0.2800	n.a.	0.3044	0.2817	0.2788	n.a.	0.3168	0.2947	0.2916	n.a.
Portugal	0.3967	0.3773	0.3708	0.3676	0.3907	0.3713	0.3650	0.3624	0.3916	0.3722	0.3663	0.3642
UK	0.3122	0.3139	0.3049	0.3172	0.3118	0.3142	0.3063	0.3178	0.3223	0.3250	0.3183	0.3286
Sweden	n.a.	n.a.	n.a.	0.2292	n.a.	n.a.	n.a.	0.2229	n.a.	n.a.	n.a.	0.2335

Figure 1
INEQUALITY RANKING (1993-1996); $\alpha = 0,50$

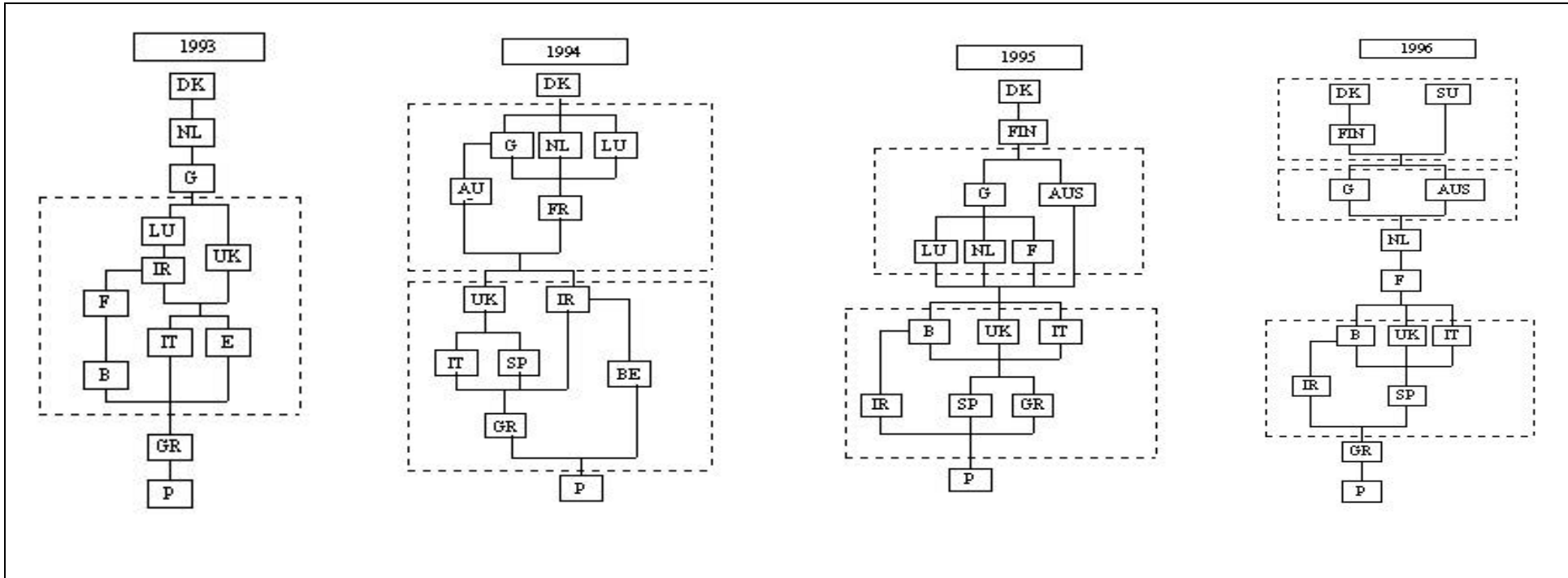

Figure 2
INEQUALITY RANKING 1996 ($\alpha = 0.25, 0.50, 0.75$)

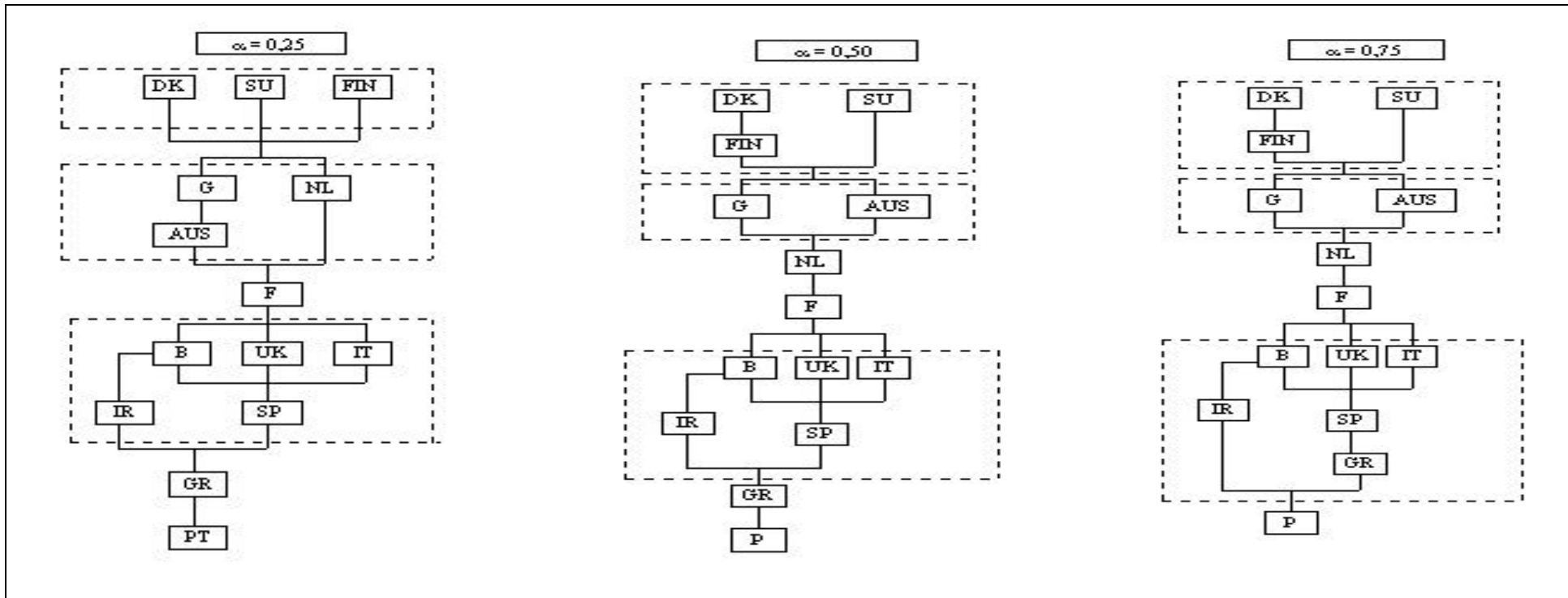

Figure 3

COUNTRIES WHERE INEQUALITY HAS MONOTONICALLY DECREASED DURING PERIOD 1993-1996

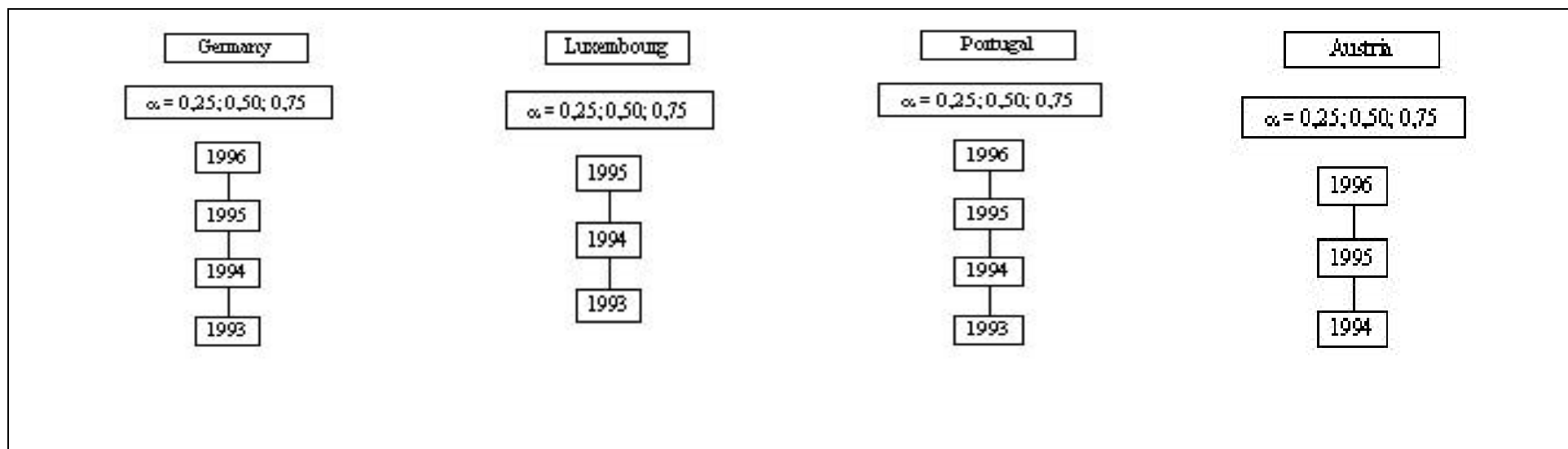

Figure 4

COUNTRIES WHERE INEQUALITY HAS NON-MONOTONICALLY DECREASED DURING PERIOD 1993-1996

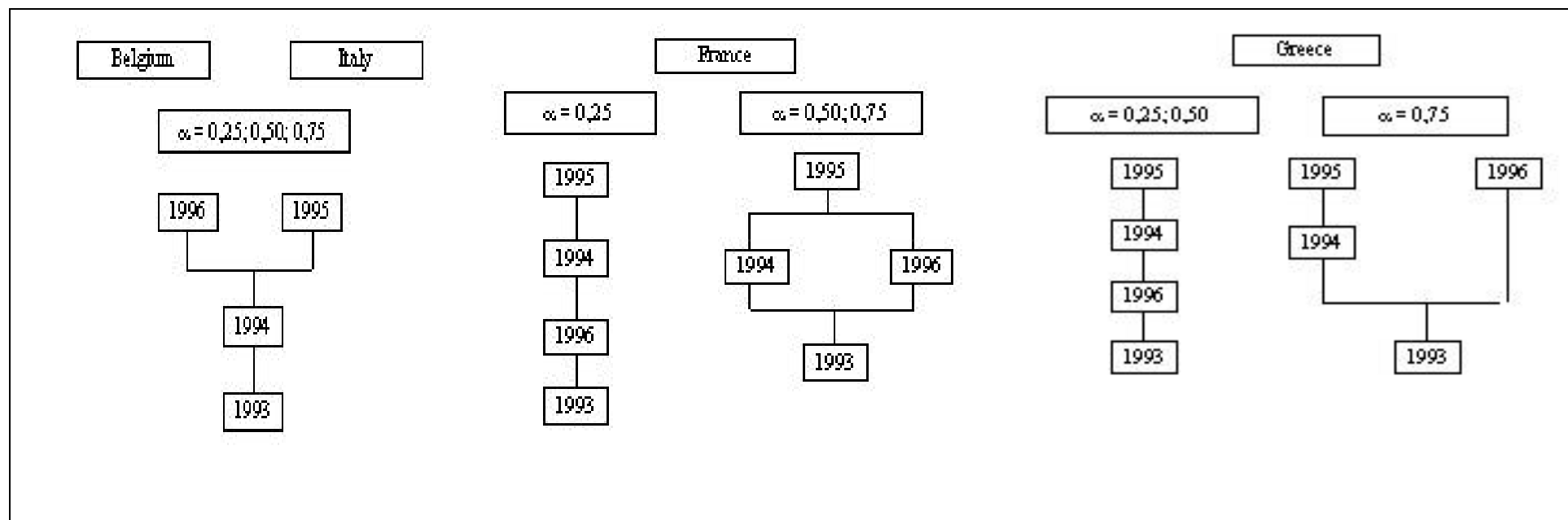

Figure 5

COUNTRIES WHERE INEQUALITY HAS AMBIGUOUSLY CHANGED DURING PERIOD 1993-1996

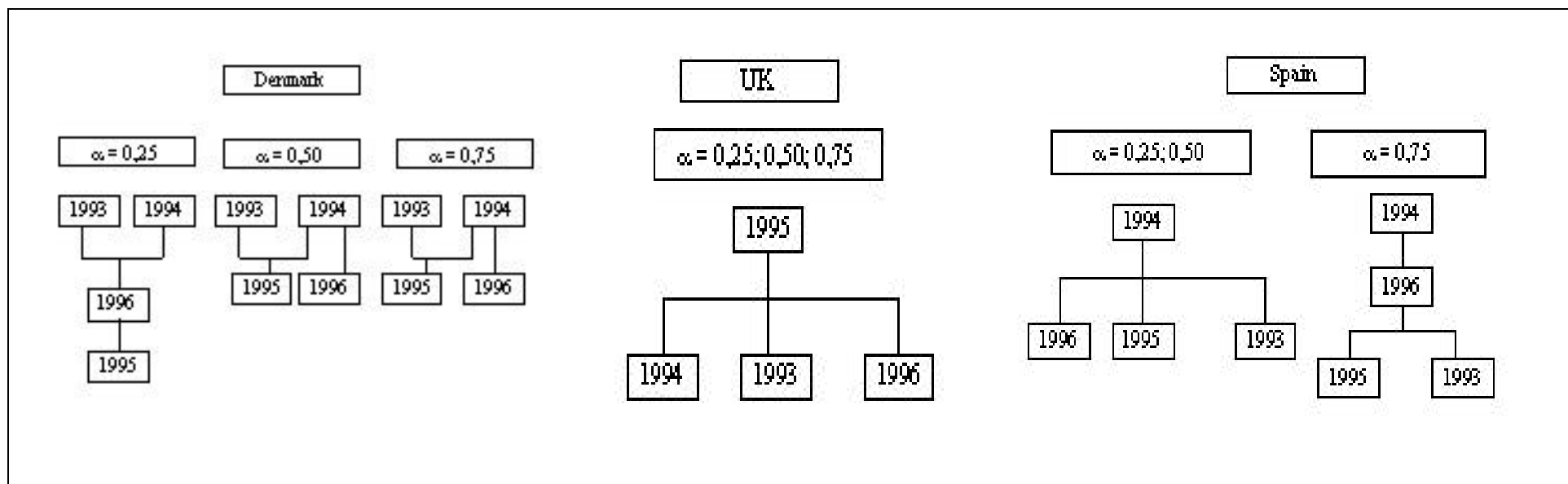

Figure 6

COUNTRIES WHERE INEQUALITY HAS NON-MONOTONICALLY INCREASED DURING PERIOD 1993-1996

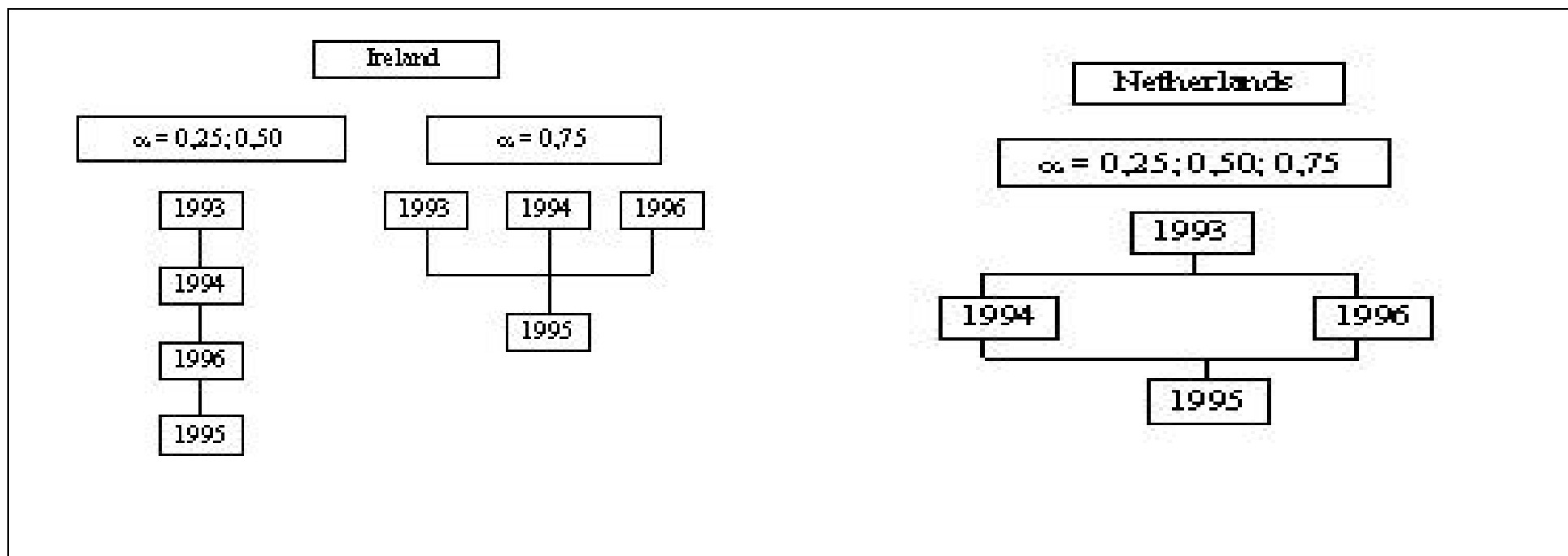
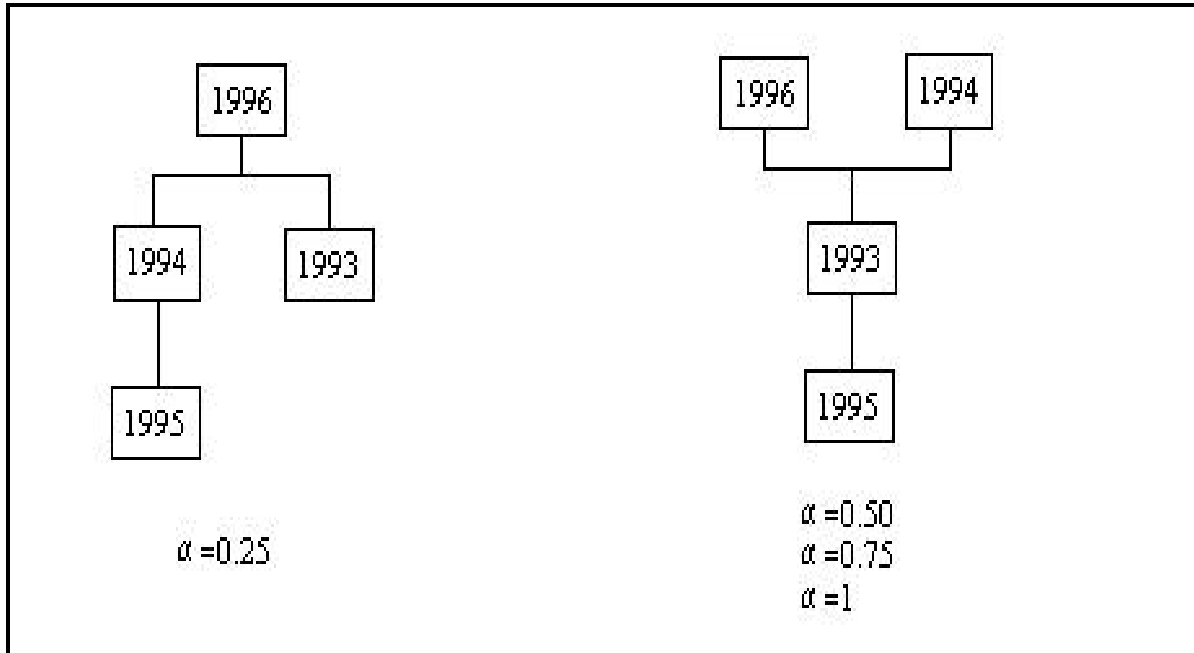

Figure 7

BETWEEN-COUNTRIES INEQUALITY (base on exchange rates homogenisation)



REFERENCES

- AABERGE, R. (2001): "Ranking Intersecting Lorenz Curves", mimeo, presented at the Thrid Annual Workshop of the Living Standard, Inequality and Taxation Network, Universidad Carlos III, Colmenarejo, Madrid.
- COULTER, F.A., COWELL, F.A. y S.P. JENKINS (1992): "Difference in Needs and Assessment of Income Distributions", *Bulletin of Economic Research*, 44, 77-124.
- DONALDSON, D. y J.A. WEYMARK (1980): " A Single Parameter Generalization of the Gini Index and Inequality", *Journal of Economic Theory*, 22, 67-86.
- (1983): "Ethical Flexible Indices for Income Distributions in the Continuum", *Journal of Economic Theory*, 29, 353-358.
- KAKWANI, N.C. (1980): "On a Class of Poverty Measures", *Econometrica*, 48, 437-446.
- MULIERE, P. y M. SCARSINI (1989): "A Note on Stochastic Dominance and Inequality Measures", *Journal of Economic Theory*, 49, 314-323.
- SALAS, R. (2002): "Multilevel Interterritorial Convergence and Additive Multidimensional Inequality Decomposition", *Social Choice and Welfare*, 19, 201-218.
- YITZHAKI, S. (1983): "On an Extension of the Gini Inequality Index", *International Economic Review*, 24, 617-628.
- ZOLI, C. (1999): "Intersecting Generalized Lorenz Curves and the Gini Index", *Social Choice and Welfare*, 16, 183-196.

NORMAS DE PUBLICACIÓN DE PAPELES DE TRABAJO DEL INSTITUTO DE ESTUDIOS FISCALES

Esta colección de *Papeles de Trabajo* tiene como objetivo ofrecer un vehículo de expresión a todas aquellas personas interesadas en los temas de Economía Pública. Las normas para la presentación y selección de originales son las siguientes:

1. Todos los originales que se presenten estarán sometidos a evaluación y podrán ser directamente aceptados para su publicación, aceptados sujetos a revisión, o rechazados.
2. Los trabajos deberán enviarse por duplicado a la Subdirección de Estudios Tributarios. Instituto de Estudios Fiscales. Avda. Cardenal Herrera Oria, 378. 28035 Madrid.
3. La extensión máxima de texto escrito, incluidos apéndices y referencias bibliográficas será de 7000 palabras.
4. Los originales deberán presentarse mecanografiados a doble espacio. En la primera página deberá aparecer el título del trabajo, el nombre del autor(es) y la institución a la que pertenece, así como su dirección postal y electrónica. Además, en la primera página aparecerá también un abstract de no más de 125 palabras, los códigos JEL y las palabras clave.
5. Los epígrafes irán numerados secuencialmente siguiendo la numeración arábica. Las notas al texto irán numeradas correlativamente y aparecerán al pie de la correspondiente página. Las fórmulas matemáticas se numerarán secuencialmente ajustadas al margen derecho de las mismas. La bibliografía aparecerá al final del trabajo, bajo la inscripción "Referencias" por orden alfabético de autores y, en cada una, ajustándose al siguiente orden: autor(es), año de publicación (distinguiendo a, b, c si hay varias correspondientes al mismo autor(es) y año), título del artículo o libro, título de la revista en cursiva, número de la revista y páginas.
6. En caso de que aparezcan tablas y gráficos, éstos podrán incorporarse directamente al texto o, alternativamente, presentarse todos juntos y debidamente numerados al final del trabajo, antes de la bibliografía.
7. En cualquier caso, se deberá adjuntar un disquete con el trabajo en formato word. Siempre que el documento presente tablas y/o gráficos, éstos deberán aparecer en ficheros independientes. Asimismo, en caso de que los gráficos procedan de tablas creadas en excel, estas deberán incorporarse en el disquete debidamente identificadas.

Junto al original del Papel de Trabajo se entregará también un resumen de un máximo de dos folios que contenga las principales implicaciones de política económica que se deriven de la investigación realizada.

PUBLISHING GUIDELINES OF WORKING PAPERS AT THE INSTITUTE FOR FISCAL STUDIES

This serie of *Papeles de Trabajo* (working papers) aims to provide those having an interest in Public Economics with a vehicle to publicize their ideas. The rules governing submission and selection of papers are the following:

1. The manuscripts submitted will all be assessed and may be directly accepted for publication, accepted with subjections for revision or rejected.
2. The papers shall be sent in duplicate to Subdirección General de Estudios Tributarios (The Deputy Direction of Tax Studies), Instituto de Estudios Fiscales (Institute for Fiscal Studies), Avenida del Cardenal Herrera Oria, nº 378, Madrid 28035.
3. The maximum length of the text including appendices and bibliography will be no more than 7000 words.
4. The originals should be double spaced. The first page of the manuscript should contain the following information: (1) the title; (2) the name and the institutional affiliation of the author(s); (3) an abstract of no more than 125 words; (4) JEL codes and keywords; (5) the postal and e-mail address of the corresponding author.
5. Sections will be numbered in sequence with arabic numerals. Footnotes will be numbered correlatively and will appear at the foot of the corresponding page. Mathematical formulae will be numbered on the right margin of the page in sequence. Bibliographical references will appear at the end of the paper under the heading "References" in alphabetical order of authors. Each reference will have to include in this order the following terms of references: author(s), publishing date (with an a, b or c in case there are several references to the same author(s) and year), title of the article or book, name of the journal in italics, number of the issue and pages.
6. If tables and graphs are necessary, they may be included directly in the text or alternatively presented altogether and duly numbered at the end of the paper, before the bibliography.
7. In any case, a floppy disk will be enclosed in Word format. Whenever the document provides tables and/or graphs, they must be contained in separate files. Furthermore, if graphs are drawn from tables within the Excell package, these must be included in the floppy disk and duly identified.

Together with the original copy of the working paper a brief two-page summary highlighting the main policy implications derived from the research is also requested.

ÚLTIMOS PAPELES DE TRABAJO EDITADOS POR EL INSTITUTO DE ESTUDIOS FISCALES

2000

- 1/00 Crédito fiscal a la inversión en el impuesto de sociedades y neutralidad impositiva: Más evidencia para un viejo debate.
Autor: Desiderio Romero Jordán.
Páginas: 40.
- 2/00 Estudio del consumo familiar de bienes y servicios públicos a partir de la encuesta de presupuestos familiares.
Autores: Ernesto Carrillo y Manuel Tamayo.
Páginas: 40.
- 3/00 Evidencia empírica de la convergencia real.
Autores: Lorenzo Escot y Miguel Ángel Galindo.
Páginas: 58.

Nueva Época

- 4/00 The effects of human capital depreciation on experience-earnings profiles: Evidence salaried spanish men.
Autores: M. Arrazola, J. de Hevia, M. Risueño y J. F. Sanz.
Páginas: 24.
- 5/00 Las ayudas fiscales a la adquisición de inmuebles residenciales en la nueva Ley del IRPF: Un análisis comparado a través del concepto de coste de uso.
Autor: José Félix Sanz Sanz.
Páginas: 44.
- 6/00 Las medidas fiscales de estímulo del ahorro contenidas en el Real Decreto-Ley 3/2000: análisis de sus efectos a través del tipo marginal efectivo.
Autores: José Manuel González Páramo y Nuria Badenes Pla.
Páginas: 28
- 7/00 Análisis de las ganancias de bienestar asociadas a los efectos de la Reforma del IRPF sobre la oferta laboral de la familia española.
Autores: Juan Prieto Rodríguez y Santiago Álvarez García.
Páginas 32.
- 8/00 Un marco para la discusión de los efectos de la política impositiva sobre los precios y el *stock* de vivienda.
Autor: Miguel-Ángel López García.
Páginas 36.
- 9/00 Descomposición de los efectos redistributivos de la Reforma del IRPF.
Autores: Jorge Onrubia Fernández y María del Carmen Rodado Ruiz.
Páginas 24.
- 10/00 Aspectos teóricos de la convergencia real, integración y política fiscal.
Autores: Lorenzo Escot y Miguel-Ángel Galindo.
Páginas 28.

2001

- 1/01 Notas sobre desagregación temporal de series económicas.
Autor: Enrique M. Quilis.
Páginas 38.
- 2/01 Estimación y comparación de tasas de rendimiento de la educación en España.
Autores: M. Arrazola, J. de Hevia, M. Risueño, J.F. Sanz.
Páginas 28.
- 3/01 Doble imposición, "efecto clientela" y aversión al riesgo.
Autores: Antonio Bustos Gisbert y Francisco Pedraja Chaparro.
Páginas 34.
- 4/01 Non-Institutional Federalism in Spain.
Autor: Joan Rosselló Villalonga.
Páginas 32.
- 5/01 Estimating utilisation of Health care: A groupe data regression approach.
Autor: Mabel Amaya Amaya.
Páginas 30.
- 6/01 Shapley inequality decomposition by factor components.
Autores: Mercedes Sastre y Alain Trannoy
Páginas 40.
- 7/01 An empirical analysis of the demand for physician services across the European Union.
Autores: Sergi Jiménez Martín, José M. Labeaga y Maite Martínez-Granado
Páginas 40.
- 8/01 Demand, childbirth and the costs of babies: evidence from spanish panel data.
Autores: José M.^a Labeaga, Ian Preston y Juan A. Sanchis-Llopis
Páginas 56.
- 9/01 Imposición marginal efectiva sobre el factor trabajo: Breve nota metodológica y comparación internacional.
Autores: Desiderio Romero Jordán y José Félix Sanz Sanz
Páginas 40.
- 10/01 A non-parametric decomposition of redistribution into vertical and horizontal components.
Autores: Irene Perrote, Juan Gabriel Rodríguez y Rafael Salas.
Páginas 28.
- 11/01 Efectos sobre la renta disponible y el bienestar de la deducción por rentas ganadas en el IRPF.
Autora: Nuria Badenes Plá.
Páginas 28.
- 12/01 Seguros sanitarios y gasto público en España. Un modelo de microsimulación para las políticas de gastos fiscales en sanidad.
Autora: Ángel López Nicolás.
Páginas 40.
- 13/01 A complete parametrical class of redistribution and progressivity measures
Autores: Isabel Rabadán y Rafael Salas.
Páginas 20.
- 14/01 La medición de la desigualdad económica.
Autor: Rafael Salas.
Páginas 40.

- 15/01 Crecimiento económico y dinámica de distribución de la renta en las regiones de la UE: un análisis no paramétrico.
Autores: Julián Ramajo Hernández y María del Mar Salinas Jiménez.
Páginas 32.
- 16/01 La descentralización territorial de las prestaciones asistenciales: efectos sobre la igualdad.
Autores: Luis Ayala Cañón, Rosa Martínez López y Jesus Ruiz-Huerta.
Páginas 48.
- 17/01 Redistribution and labour supply.
Autores: Jorge Onrubia, Rafael Salas y José Félix Sanz.
Páginas 24.
- 18/01 Medición de la eficiencia técnica en la economía española: El papel de las infraestructuras productivas.
Autoras: M.^a Jesús Delgado Rodríguez e Inmaculada Álvarez Ayuso.
Páginas 32.
- 19/01 Inversión pública eficiente e impuestos distorsionantes en un contexto de equilibrio general.
Autores: José Manuel González-Páramo y Diego Martínez López.
Páginas 28.
- 20/01 La incidencia distributiva del gasto público social. Análisis general y tratamiento específico de la incidencia distributiva entre grupos sociales y entre grupos de edad.
Autor: Jorge Calero Martínez.
Páginas 36.
- 21/01 Crisis cambiarias: Teoría y evidencia.
Autor: Óscar Bajo Rubio.
Páginas 32.
- 22/01 Distributive impact and evaluation of devolution proposals in Japanese local public finance.
Autores: Kazuyuki Nakamura, Minoru Kunizaki and Masanori Tahira.
Páginas 36.
- 23/01 El funcionamiento de los sistemas de garantía en el modelo de financiación autonómica.
Autor: Alfonso Utrilla de la Hoz.
Páginas 48.
- 24/01 Rendimiento de la educación en España: Nueva evidencia de las diferencias entre Hombres y Mujeres.
Autores: M. Arrazola y J. de Hevia.
Páginas 36.
- 25/01 Fecundidad y beneficios fiscales y sociales por descendientes.
Autora: Anabel Zárate Marco.
Páginas 52.
- 26/01 Estimación de precios sombra a partir del análisis Input-Output: Aplicación a la economía española.
Autora: Guadalupe Souto Nieves.
Páginas 56.
- 27/01 Análisis empírico de la depreciación del capital humano para el caso de las Mujeres y los Hombres en España.
Autores: M. Arrazola y J. de Hevia.
Páginas 28.

- 28/01 Equivalence scales in tax and transfer policies.
Autores: Luis Ayala, Rosa Martínez y Jesús Ruiz-Huerta
Páginas 44.
- 29/01 Un modelo de crecimiento con restricciones de demanda: el gasto público como amortiguador del desequilibrio externo.
Autora: Belén Fernández Castro.
Páginas 44.
- 30/01 A bi-stochastic nonparametric estimator.
Autores: Juan G. Rodríguez and Rafael Salas.
Páginas 24.

2002

- 1/02 Las cestas autonómicas.
Autores: Alejandro Esteller, Jorge Navas y Pilar Sorribas.
Páginas 72.
- 2/02 Evolución del endeudamiento autonómico entre 1985 y 1997: la incidencia de los Escenarios de Consolidación Presupuestaria y de los límites de la LOFCA.
Autores: Julio López Laborda y Jaime Vallés Giménez.
Páginas 60.
- 3/02 Optimal Pricing and Grant Policies for Museums.
Autores: Juan Prieto Rodríguez y Víctor Fernández Blanco.
Páginas 28.
- 4/02 El mercado financiero y el racionamiento del endeudamiento autonómico.
Autores: Nuria Alcalde Fradejas y Jaime Vallés Giménez.
Páginas 36.
- 5/02 Experimentos secuenciales en la gestión de los recursos comunes.
Autores: Lluís Bru, Susana Cabrera, C. Monica Capra y Rosario Gomez.
Páginas 32.
- 6/02 La eficiencia de la universidad medida a través de la función de distancia: Un análisis de las relaciones entre la docencia y la investigación.
Autores: Alfredo Moreno Sáez y David Trillo del Pozo.
Páginas 40.
- 7/02 Movilidad social y desigualdad económica.
Autores: Juan Prieto-Rodríguez, Rafael Salas y Santiago Álvarez-García.
Páginas 32.
- 8/02 Modelos BVAR: especificación, estimación e inferencia.
Autor: Enrique M. Quilis.
Páginas 44.
- 9/02 Imposición lineal sobre la renta y equivalencia distributiva: un ejercicio de microsimulación.
Autores: Juan Manuel Castañer Carrasco y José Felix Sanz Sanz.
Páginas 44.
- 10/02 The evolution of income inequality in the European Union.
Autores: Santiago Álvarez-García, Juan Prieto-Rodríguez y Rafael Salas.
Páginas 36.