

**Design of a  
Period Batch Control  
Planning System  
for  
Cellular Manufacturing  
  
Jan Riezebos**

CIP-GEGEVENS KONINKLIJKE BIBLIOTHEEK, DEN HAAG

Riezebos, Jan

The design of a period batch control planning system for cellular manufacturing  
/ Jan Riezebos. – [S.l.:s.n.]-I11.

Thesis University of Groningen, Groningen, the Netherlands

With references– With summary in Dutch–

ISBN 90-367-1341-2

Keywords: production planning, production system, cellular manufacturing

© J. Riezebos, 2001

Printed by PrintPartners Ipskamp B.V., Enschede, the Netherlands

*All rights reserved. No part of this publication may be reproduced, stored in a retrieval system, or transmitted in any form by any means, electronic, mechanical, photocopying, recording or otherwise, without the written permission of the author.*

RIJKSUNIVERSITEIT GRONINGEN

**Design of a  
Period Batch Control  
Planning System  
for  
Cellular Manufacturing**

PROEFSCHRIFT

ter verkrijging van het doctoraat in de

Bedrijfskunde

aan de Rijksuniversiteit Groningen

op gezag van de

Rector Magnificus, dr. D.F.J. Bosscher,

in het openbaar te verdedigen op

donderdag 4 januari 2001

om 14.15 uur

door

**Jan Riezebos**

geboren op 28 juli 1966

te IJsselmuiden

Promotor

Prof. dr. ir. G.J.C. Gaalman

Beoordelingscommissie Prof. dr. A.G. de Kok  
Prof. dr. N.C. Suresh  
Prof. dr. J. Wijngaard

ISBN 90-367-1341-2

STELLINGEN

behorende bij het proefschrift

*Design of a*

*Period Batch Control*

*Planning System*

*for*

*Cellular Manufacturing*

van

Jan Riezebos

4 januari 2001

Een afname in de totale voorraad onderhanden werk kan bereikt worden door het aantal tussenvoorraadposities te laten toenemen.

*(Dit proefschrift)*

Het pleidooi voor een geringer aantal niveaus in de stuklijst zoals gevoerd in planningsliteratuur m.b.t. groepsgewijze productie<sup>1</sup> houdt onvoldoende rekening met het effect op de performance van het productiesysteem.

*(Dit proefschrift) (<sup>1</sup> zie Wemmerlöv [1988: 28], Steudel & Desruelle [1992: 272])*

Gebruik van transfer batches in flow shops levert de grootste verbetering van de make span indien gecombineerd met permutation flow shop schedules.

*(Dit proefschrift)*

De taak van productieplanning wordt niet eenvoudiger door het productiesysteem op te delen in teams.

*(Dit proefschrift)*

Om te kunnen vaststellen of het wenselijk is een instrument te gebruiken is het noodzakelijk maar niet voldoende om de effectiviteit ervan aan te tonen. Dit geldt zowel voor de doodstraf als voor het in dit proefschrift bestudeerde plannings-instrument PBC.

Het *christmas tree problem* is geen speciaal geval van het *cutting tree* problem.

Management concepten zijn als homeopatische geneesmiddelen: zowel zij die het voorschrijven als die er gebruik van maken wachten wetenschappelijk bewijs van werking en mogelijke bijwerkingen niet af.

Gezien het toenemende aantal publicaties waarin kritiek wordt geuit op de *moderne* sociotechniek is er behoefte aan een *postmoderne* sociotechniek.

Pogingen om op basis van een economische waardering van vrijwilligerswerk en onbetaalde zorgtaken het maatschappelijk belang te duiden nemen ten onrechte het economisch hegemonisme als uitgangspunt.

De bestaansgrond van wetenschap is niet het bevestigen van intuïtie, maar het bevragen ervan.

*(n.a.v. H. Mulisch, De ontdekking van de hemel, 1992)*

Wetenschap dient niet blindelings te werken aan de grenzen van het weten, maar weet te hebben van de grenzen van haar denkkaders en instrumentarium.

Basisscholen gaan professioneler om met het herkennen en inpassen van over- en onderpresterende hoogbegaafden in hun onderwijssysteem dan universiteiten.

Toepassing van het poldermodel leidt tot vervlakkings.

WORD wordt nooit *perfect*.

## PREFACE AND ACKNOWLEDGEMENTS

Doing research is an exciting activity. It raises much more questions that remain unanswered, as compared to the actual progress that is obtained. I consider this to be one of the most important contributions of scientific work. We should never stop thinking and raising questions about fundamental choices that are made. In order to determine how to move forward, we have to look back. This thesis is the result of such a backward looking activity. As an assistant professor production management and production system design, I visited many firms that coped with production planning problems. Some of them expected to eliminate these problems by changing their production system into a cellular manufacturing system. Others were disappointed with respect to the results they obtained with their cellular organized production system. I wondered to what extent the production planning systems of firms could be redesigned such that the benefits of cellular manufacturing became within reach. Therefore, I started to study literature on the design of planning systems for cellular manufacturing. Many of these studies pointed towards the work of Burbidge on Period Batch Control (PBC). It is a simple and rather straightforward system, based upon repetition, and easily adaptable to specific situations that require tailor made solutions. Unfortunately, the same holds true for the descriptions of PBC in literature. The main contribution of my research project is to provide a scientific body of knowledge on period batch control planning systems for cellular manufacturing. I have worked on it with enthusiasm and excitement.

Doing research is also a long-term activity. It has taken six years to finish this thesis. The most difficult questions during this time were about the remaining amount of time necessary to finish the thesis, and not only because I didn't know the answer. The main struggle in the research project was to convince myself of the worthiness of this study. I thank my supervisor Gerard Gaalman, for understanding me in these parts of the project as well. He continuously expressed his faith in my ability to finish this thesis. I enjoyed the inspiring discussions and the friendly atmosphere that he created for working at this thesis. I express my thanks to the members of my dissertation committee, Jacob Wijngaard, Nallan Suresh, and Ton de Kok, for their willingness to read the manuscript carefully. It has costed them a lot of time and energy, and I am grateful for their efforts. Peter van Dam and Martin Land often have motivated me to keep on working at the thesis. I am indebted to them and to other -former- members of my department and faculty for stimulating and enabling me to work at this subject.

Invaluable support has been given by people that were not able to understand what I was doing. My parents have stimulated me to develop my abilities and not to forget the relativity of all knowledge that can be gained in this world. Stefan and Menno have shown that it is worthwhile to evaluate learning processes and consider them from another (their) point of view. Lucia has kept an eye on me. I appreciate her sensitivity, sympathy, and loyalty.

PREFACE AND ACKNOWLEDGEMENTS.....	i
CHAPTER 1 INTRODUCTION .....	1
§ 1.1 DEFINITION OF THE AREA OF APPLICATION.....	1
§ 1.2 RELEVANT FACTORS IN THE DESIGN OF A PLANNING SYSTEM.....	3
§ 1.2.1 Historical developments in the field of production planning and control	4
§ 1.2.2 Summary	11
§ 1.3 RESEARCH QUESTIONS .....	12
§ 1.4 OUTLINE OF THESIS .....	14
CHAPTER 2 RELATIONSHIPS BETWEEN CELLS IN CELLULAR MANUFACTURING.....	17
§ 2.1 LITERATURE ON RELATIONSHIPS BETWEEN CELLS.....	18
§ 2.2 SEQUENTIAL, SIMULTANEOUS, AND LATENT RELATIONSHIPS BETWEEN CELLS .....	23
§ 2.2.1 Sequential relationships	25
§ 2.2.2 Simultaneous relationships	26
§ 2.2.3 Latent relationships	27
§ 2.3 RELATIONSHIPS BETWEEN CELLS IN PRACTICE .....	28
§ 2.3.1 Sequential relationships	29
§ 2.3.2 Simultaneous relationship	34
§ 2.3.3 Latent relationships	35
§ 2.4 CONCLUSION.....	37
CHAPTER 3 PERIOD BATCH CONTROL.....	39
§ 3.1 PRINCIPLES OF PERIOD BATCH CONTROL.....	39
§ 3.1.1 Basic Unicycle PBC is a Single Cycle system	41
§ 3.1.2 Basic Unicycle PBC is a Single Phase system	43
§ 3.1.3 Basic Unicycle PBC is a Single Offset time system	44
§ 3.1.4 Variants of PBC in practice	46
§ 3.1.5 Operation of a PBC system	48
§ 3.1.6 Planning functions in program meetings	50
§ 3.2 SUITABILITY OF PBC FOR CELLULAR MANUFACTURING .....	54
§ 3.3 PBC PLANNING SYSTEM EVOLUTION.....	56
§ 3.3.1 Single cycle ordering versus economic ordering	57
§ 3.3.2 Single cycle, single phase, single offset time planning	58
§ 3.3.3 PBC system design	60
§ 3.3.4 Group Technology and PBC	62
§ 3.3.5 Stable loading and single cycle programming	63
§ 3.3.6 Overlapping production and multi phase cyclical planning	66
§ 3.3.7 Information technology and PBC	67
§ 3.3.8 Cyclical planning to improve rather than just co-ordinate production	70
§ 3.3.9 PBC, MRP and Kanban	72
§ 3.3.10 Concluding remarks	73
§ 3.4 OUTLINE OF RESEARCH ON PERIOD BATCH CONTROL SYSTEM DESIGN .....	74

CHAPTER 4 DESIGN FACTORS FOR BASIC UNICYCLE PBC SYSTEMS .....	77
§ 4.1 CONCURRENT DESIGN OF PRODUCTION SYSTEM AND PLANNING SYSTEM .....	77
§ 4.1.1 Relationship between production systems and planning systems	78
§ 4.1.2 Planning literature and production system structure	80
§ 4.1.3 PBC literature on production and planning system design	83
§ 4.2 LENGTH OF PLANNING PERIOD P .....	85
§ 4.2.1 Choice of period length	85
§ 4.2.2 Trade-offs in the choice of period	89
§ 4.3 STAGE DEFINITION: NUMBER OF STAGES N .....	91
§ 4.3.1 Processing stage definition with Production Flow Analysis	92
§ 4.3.2 Decomposition of the Period Batch Control system into stages	95
§ 4.4 STAGE DEFINITION: ALLOCATION OF OPERATIONS TO STAGES .....	99
§ 4.4.1 The relationship between cells and stages	100
§ 4.4.2 Stages with operations performed in various cells	101
§ 4.4.3 Cells with operations performed within various stages	103
§ 4.4.4 Relevant factors for allocation of operations to stages	107
§ 4.4.5 Reconsidering the relationship between cells and stages	109
§ 4.5 SUMMARY AND CONCLUSIONS .....	110
 CHAPTER 5 MODELS AND METHODS FOR DETERMINING A PERIOD LENGTH P .....	 113
§ 5.1 DETAILED DECOUPLED PERIOD DETERMINATION .....	114
§ 5.2 CLASSICAL ECONOMIC PERIOD DETERMINATION .....	118
§ 5.3 MODELLING DETAILED ECONOMIC PERIOD DETERMINATION .....	120
§ 5.4 MODELLING DIFFERENT NUMBER OF SUBBATCHES PER OPERATION .....	124
§ 5.4.1 Non-nested batching policy $nb_{hi-1} \geq nb_{hi}$	125
§ 5.4.2 Nested batching policy $nb_{hi-1} \leq nb_{hi}$	128
§ 5.4.3 Period length determination with (non)-nested batching policies	132
§ 5.5 SOLUTION METHODS FOR DETAILED ECONOMIC PERIOD DETERMINATION MODEL .....	135
§ 5.5.1 Exploring the cost structure of the model with equal subbatches	136
§ 5.5.2 Variable batching strategies: an enumerative search heuristic	142
§ 5.5.3 Solution approach for the complete model: progressive search heuristic	145
§ 5.6 COMPARING THE HEURISTICS: AN EXHAUSTIVE SEARCH HEURISTIC .....	147
§ 5.7 CONCLUSIONS .....	150

CHAPTER 6	MODELLING THE TRADE-OFF BETWEEN N AND P .....	153
§ 6.1	TRADE-OFF BETWEEN N SMALL & P LARGE AND N LARGE & P SMALL .....	154
§ 6.2	DESIGN OF A SIMULATION MODEL .....	159
§ 6.2.1	Modelling overtime in a PBC system .....	159
§ 6.2.2	Characteristics of the production situation in the simulation analysis .....	160
§ 6.2.3	Model of Period Batch Control planning system .....	162
§ 6.2.4	Simulation modelling environment .....	167
§ 6.3	PERFORMANCE OF PBC IN PRODUCTION SITUATION I .....	167
§ 6.3.1	Experimental design .....	167
§ 6.3.2	Expected effects of experimental design factors in production situation I .....	169
§ 6.3.3	Methodology used to analyse the results .....	170
§ 6.3.4	Effect of PBC configuration on amount of overtime work .....	171
§ 6.3.5	Effect of PBC configuration on costs .....	178
§ 6.4	PERFORMANCE OF PBC IN PRODUCTION SITUATION II .....	181
§ 6.4.1	Results for production situation II .....	182
§ 6.4.2	Conclusions on comparing production situations I and II .....	185
§ 6.5	CONCLUSIONS .....	185
CHAPTER 7	DETERMINING A CONFIGURATION OF THE PBC SYSTEM .....	187
§ 7.1	PBC CONFIGURATION PROPOSED BY PROGRESSIVE SEARCH HEURISTIC .....	188
§ 7.1.1	Results of progressive search heuristic without correction factor ( $MI = 1$ ) .....	189
§ 7.1.2	Evaluation of proposed configuration in simulation model .....	190
§ 7.1.3	Results of progressive search heuristic with correction factor $MI < 1$ .....	193
§ 7.2	PBC SYSTEM DESIGN AND THE VALUE OF A SEARCH HEURISTIC .....	195
§ 7.3	CONCLUSION .....	198
CHAPTER 8	CO-ORDINATION BETWEEN CELLS AND PBC SYSTEM DESIGN .....	199
§ 8.1	EFFECT OF PBC SYSTEM DESIGN ON UNCERTAINTY IN A CELLULAR SYSTEM .....	200
§ 8.1.1	Uncertainty in cellular manufacturing systems .....	200
§ 8.1.2	Conversion uncertainty .....	202
§ 8.1.3	Boundary transaction uncertainty within cells .....	204
§ 8.1.4	Boundary transaction uncertainty across cell boundaries .....	206
§ 8.1.5	PBC design and latent relationships between cells .....	208
§ 8.1.6	Uncertainty and co-ordination requirements .....	209
§ 8.2	STAGE CO-ORDINATION AS PART OF THE PLANNING SYSTEM .....	210
§ 8.2.1	Stage co-ordination .....	211
§ 8.2.2	Functional architecture of stage co-ordination within PBC planning .....	213
§ 8.2.3	Examples of stage co-ordination .....	215
§ 8.2.4	Final remarks .....	216
§ 8.3	CONCLUSIONS .....	216

CHAPTER 9 CONCLUSIONS AND FURTHER RESEARCH .....	217
§ 9.1 CONCLUSIONS .....	217
§ 9.2 RECOMMENDATIONS FOR FURTHER RESEARCH .....	223
APPENDIX A. SHORT CASE DESCRIPTIONS .....	227
A.I. CASE I COMPLEX MACHINES .....	228
A.II. CASE II COMPLETE INSTALLATIONS .....	229
A.III. CASE III COMPLEX INSTALLATION .....	231
A.IV. CASE IV PARTS PRODUCTION MAKE/ENGINEER TO ORDER .....	232
A.V. CASE V PARTS PRODUCTION MAKE TO ORDER .....	233
A. SUMMARY OF CASE DESCRIPTIONS .....	235
APPENDIX B. MIXED INTEGER PROGRAMMING FOR STAGE ALLOCATION .....	237
B.I. LONGEST-PATH ORIENTATION IN MIXED INTEGER PROGRAMMING MODEL .....	238
B.II. BOTTLENECK ORIENTATION IN MIXED INTEGER PROGRAMMING MODEL.....	239
B.III. APPLICATION OF MIXED INTEGER MODEL ON PRODUCTION SITUATION I.....	241
APPENDIX C. PROOF OF EQUIVALENCE BETWEEN FORMULA 5.2 AND 5.3.....	243
APPENDIX D. EXPLORING RELATED PROBLEMS WITH SUBBATCHES.....	245
D.I. REPETITIVE LOTS.....	245
D.II. OVERLAPPING OPERATIONS IN A FLOW SHOP .....	246
D.III. LOT STREAMING .....	246
APPENDIX E. PROGRESSIVE SEARCH HEURISTIC .....	247
E.I. DETAILED DESCRIPTION OF PROGRESSIVE SEARCH HEURISTIC.....	247
E.II. APPLICATION OF PROGRESSIVE SEARCH HEURISTIC ON EXAMPLE PROBLEM.....	250
APPENDIX F. VERIFICATION AND VALIDATION OF THE SIMULATION MODEL .....	251
F.I. VERIFICATION OF THE SIMULATION MODEL.....	251
F.II. VALIDATION.....	252
APPENDIX G. MODIFICATIONS IN PROGRESSIVE SEARCH HEURISTIC.....	255
G.I. MODIFICATIONS IN LOWERBOUNDS ON P .....	255
G.II. MODIFICATIONS IN MODELLING COMPLETION TIME.....	257
G.III. MODIFICATIONS IN COST STRUCTURE.....	259
REFERENCES .....	261
AUTHOR INDEX.....	269
SUMMARY .....	271
SAMENVATTING .....	273

---

**LIST OF FIGURES**

Figure 1.1 Pressures to change towards cellular manufacturing	2
Figure 2.1 Interdependency between system elements	19
Figure 2.2 Reciprocal interdependency between cells in transformation process	19
Figure 2.3 Product redesign with cell dedication types 1 and 2	21
Figure 2.4 Latent relationships between cells	27
Figure 2.5 Five types of sequential relationships with a cell	28
Figure 3.1 Unicycle (a) and Basic Unicycle (b) PBC system (compare Figure 3.11)	40
Figure 3.2 Basic PBC scheme	41
Figure 3.3 Surge effect: load fluctuations due to unequal planning frequencies	42
Figure 3.4 Work order definition in MRP and PBC	44
Figure 3.5 Example of traditional versus single offset time Bill of Material	45
Figure 3.6 Kumera Oy Cyclical planning system	47
Figure 3.7 PBC system with 3 stages	48
Figure 3.8 Customer order lead time L versus Throughput time T	49
Figure 3.9 Master Production Scheduling versus PBC Flexible Programming	51
Figure 3.10 Operation of a PBC system (free to Burbidge [1975a: figure 4.2])	53
Figure 3.11 Cycle, Phase, and Offset time (a,c,d according to Burbidge [1962, fig 33])	58
Figure 3.12 Essential features of period batch control (Burbidge, 1962)	60
Figure 3.13 Cyclic planning according to Burbidge [1975a: figure 3.6]	65
Figure 3.14 Flow shop cyclical planning	66
Figure 4.1 Traditional sequence design process	78
Figure 4.2 Mutual interaction between design of production and planning system	78
Figure 4.3 Set-up time effect	87
Figure 4.4 Start/finish effect	88
Figure 4.5 Effect of reduction of period length P	89
Figure 4.6 Original stage allocation	100
Figure 4.7 Alternative stage allocation	100
Figure 4.8 Operations involving various cells within the same stage	101
Figure 4.9 Cells with operations performed within various stages	103
Figure 4.10 Work load distribution if cells are simultaneously active in various stages	104
Figure 4.11 Traditional perspective on PBC synchronization	109
Figure 4.12 New perspectives on PBC synchronization	110
Figure 5.1 Build up of inventory (WIP and finished goods) during stages	120
Figure 5.2 Computing earliest starting time at operation $i$ in the non-nested case	126
Figure 5.3 $ra_{hi}=rs_{hi}$ : operation $i$ starts without interruption if first subbatch at $i$ arrives	127
Figure 5.4 Non-powered nested batching policies result in temporally stock	129
Figure 5.5 Powered nested batching at $i$ generate less machine waiting time at $i+1$	131
Figure 5.6 Partial and total cost curves	137

Figure 5.7 Conditional and actual total cost curves for increasing numbers of subbatches	139
Figure 5.8 Change in actual cost curves for various equal number of subbatch policies	141
Figure 5.9 Enumerative search heuristic that finds P, N, and $nb_{hi}$ with minimal cost	143
Figure 5.10 Cost of solutions obtained with enumerative search heuristic	144
Figure 5.11 Structure of progressive search heuristic (details in Appendix D)	146
Figure 5.12 Performance progressive search heuristic	148
Figure 6.1 Effects of PBC configuration change through reduction of T	154
Figure 6.2 Trade-off between PBC configurations with identical throughput time	155
Figure 6.3 $N=2, P=1\frac{1}{2}$ (N small & P large)	155
Figure 6.4 $N=6, P=\frac{1}{2}$ (N large & P small)	155
Figure 6.5 Increase of Work In Progress if $P\uparrow$ and $N\downarrow$	157
Figure 6.6 Lower bottleneck utilization if $N\downarrow$ and $P\uparrow$	157
Figure 6.7 Increase in overlapping production if $N\downarrow$ and $P\uparrow$	158
Figure 6.8 Part routings in simulated production situation I	160
Figure 6.9 Bill Of Material in production situation I	162
Figure 6.10 Simulation model of a PBC planning system	163
Figure 6.11 Applied stage allocation in simulation of production situation I	164
Figure 6.12 Details on flow control in PBC	165
Figure 6.13 Cost curves for combinations of N and NrSub	179
Figure 6.14 Total cost as function of total number of transfers during T	180
Figure 7.1 Gantt chart for PBC design with $N=1, P=0.3767\cdot T, NB=3$	191
Figure 7.2 Gantt chart for minimal cost configuration of PBC: $N=2, P=0.2657\cdot T, NB=3$	194
Figure 7.3 PBC system design approach	196
Figure 8.1 Uncertainty influencing remaining co-ordination in cellular manufacturing	200
Figure 8.2 Uncertainty within cells	201
Figure 8.3 Three components of uncertainty in cellular manufacturing	201
Figure 8.4 Uncertainty caused by sequential relationship between cells within stage	208
Figure 8.5 Functional architecture of stage co-ordination level	214
Figure A.1 Goods flow case I Complex machines	228
Figure A.2 Goods flow case II Complete installations	230
Figure A.3 Goods flow case III Complex installation	231
Figure A.4 Goods flow case IV Parts production make/engineer to order	232
Figure A.5 Goods flow case V Parts production make to order	234
Figure B.1 Optimal stage allocation for production situation I (machine 13 bottleneck)	242
Figure F.1 Gantt chart used for validation of the simulation model	253
Figure G.1 Convergent product structure	256



---

## Chapter 1 Introduction

This chapter introduces the problem of planning system design in the context of a dynamic environment. The changing demands of the environment will often lead to a redesign of the production system and a redistribution of planning tasks and responsibilities within the firm. We focus on batch manufacturing systems that have chosen to apply a cellular production structure and we examine the consequences of choosing this production structure for the design of the planning system. Section § 1.1 introduces the area of application and defines the notions of group technology and cellular manufacturing that we use in this thesis. Section § 1.2 focuses on the design of a planning system. The section shows that besides developments in information technology and planning theory, changes in the organization of production and planning system and their environment have also had a strong influence on planning system design. As the introduction of cellular manufacturing entails a change in the production system, we therefore have to expect some changes in the planning system as well. This brings us to the main research questions in Section § 1.3. Section § 1.4 presents an outline of this thesis and describes the research approach used.

### § 1.1 Definition of the area of application

Most batch manufacturing firms face the need to produce both efficiently and flexibly in small batches and with short throughput times in order to stay competitive. These requirements are fundamentally different compared with some decades ago. Traditional production organization structures were designed with the aim of producing high quality products in specialized departments. These departments could either be process oriented (functional) or product oriented (lines). Both structures enabled the production system to produce efficiently. Efficiency in production lines could be a matter of well organized supporting processes, such as material transfer, making it possible to produce high volumes of standardized products. Efficiency in functional structures could be a matter of high utilization of specialized processes, making it possible to produce a large variety of products.

These traditional production organization structures have a cost. Figure 1.1 shows that production line organization is able to realize very short throughput times, but is not very flexible. On the contrary, functional organizations are very flexible, but they often involve long throughput times and low dependability. However, in order to stay competitive, batch manufacturing systems have to be both flexible and attain short throughput times.

One way to achieve this combination of objectives is to redesign the production system according to group technology principles. *Group technology* aims at searching for similarity within the production system and product structure, and at using this similarity in order to simplify the method of production. Some firms have introduced cellular manufacturing as a consequence of the application of group technology to their production system. Others

adopted cellular manufacturing as a consequence of a socio-technical redesign of the production system.

We define a *cellular manufacturing system* as a production system that is decomposed into cells, with cells being able to process several operations per work order. This set of operations per work order reduces the total number of different organizational units that are sequentially involved in producing a product. The result of a good system design is a simple but robust decomposition of the production system into cells. Cells are not over-specialized in one product only, as in traditional production lines, but are able to produce a family of parts that require the combining of processes available in the cell.

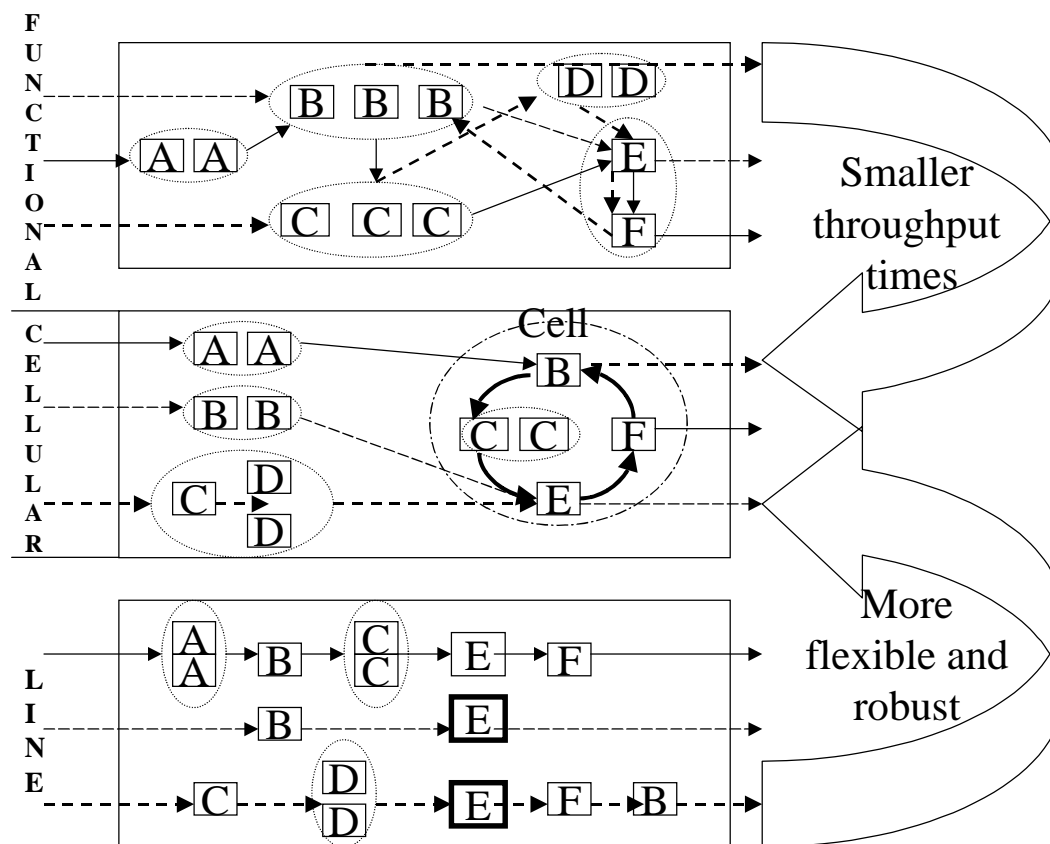

**Figure 1.1 Pressures to change towards cellular manufacturing**

Figure 1.1 shows an example of a cellular decomposition as an alternative for functional or line production. In functional organization, each product visits organizational units that are responsible for special processes (i.e., A or B). This results in a lot of material handling. The line organization uses different organizational units per product. The example in Figure 1.1 shows that this leads to extra investments in two machines that can perform process E. Furthermore, if changes occur in demand volume or mix, the capacity of a specific machine in the line may become a bottleneck, while the total amount of capacity of this machine type is still sufficient. The line production system is therefore not very flexible and the system design is less robust, as redesign has to be considered on a regular basis.

The cellular organization in Figure 1.1 shows a cell on the right side in which four different operations are combined. In this example, the routing direction within the cell is identical for all products. The operations are arranged in a circular routing, as work may enter from other parts of the system at any of the operations, and also may leave the cell after a number of operations, depending on the product. Due to mix variation, capacity imbalances for the machines within the cell will occur. Operators in a cellular manufacturing system are trained to process multiple operations within a cell in order to handle these fluctuations in machine utilization. We see that a cellular organization tries to combine several advantages of a production line system without facing the inherent weaknesses of this system.

Production planning is an important task within a manufacturing system. We define the *planning system* as that part of the manufacturing system that is responsible for regulating, co-ordinating, and monitoring the flow of work through the *production system*. The production system is that part of the manufacturing system that is responsible for performing the required transformation. The way the planning system accomplishes its function strongly influences the performance of the production system. Planning systems can differ in the way they distribute tasks and responsibilities over various organizational entities, and in the way they decompose the planning problem into subproblems (aggregation/disaggregation).

This thesis examines the changes that are required in the design of a planning system when cellular manufacturing is being applied. The study identifies the factors that have to be taken into account when designing a planning system in order to realize the desired benefits of a change towards cellular manufacturing.

## § 1.2 Relevant factors in the design of a planning system

Developments in the field of production planning during the last century have been substantial. There has been considerable progress with respect to the theoretical foundation of various aspects of production planning, such as scheduling, requirements planning, capacity planning, and so on. Another factor that has played an important role in the development of planning systems is the increase in technological possibilities for supporting the planning function, mainly through the use of computer technology. From these two factors, one can easily draw the *incorrect* conclusion that planning systems that incorporate more advanced theoretical methods and make more intensive use of computer technology are better suitable for providing support to the actual production planning task in a firm.

If we want to determine how the production planning task in cellular manufacturing should be supported, we have to understand the nature of the planning task itself and the position of the planning function within the firm. We will show the relevance of this approach through an exploration of historical developments in the field of production planning. This will help us to identify factors that must be considered when determining an adequate planning system.

### § 1.2.1 Historical developments in the field of production planning and control

Before the Industrial Revolution, which started around 1750, manufacturing activities were mainly domestic, taking place in small work shops in homes. These activities were often highly specialized, based on manual skills. The relationship between supplier and customer was based on merchandising finished products or ordering a new amount of these products that could be used as input for the customer's processes. The successive processes in the supply chain were decoupled through inventory.

The Industrial Revolution and, more specifically, Richards Arkwright's introduction of a fabric system into the textile industry (1769) reduced the geographical distance between the sites of successive processing stages. Workers, materials and machinery required for these processes were all concentrated at a site where power for the new machinery was available. It was therefore less necessary to decouple the successive processing steps through large amounts of inventory. The huge investments in new technology and the interdependency of labour and technology stimulated the development of control procedures for the availability of the various system inputs, such as raw materials, workers, water and power, in order to improve the return on investment of the new machinery. The concept of planning as an instrument for effectively coupling traditionally independent processes, i.e. a *controller point of view*<sup>1</sup>, was born.

The concept of the 'interchangeability of parts' could be introduced into fabric systems due to the development of lathes and milling machines by Henry Maudsley (1794) and Eli Whitney (1818). This interchangeability became more essential because of the increased application of steam-powered machines, which resulted in a demand for spare parts. A kind of repetitiveness emerged that became a further subject of study. The attention of management changed from selecting and developing individual craftsmen in order to produce products with sufficient quality to the design of a system that was able to produce quality products efficiently in the amounts that were required by the market. This resulted in the development of cyclical planning systems that could use the repetitive character of demand, i.e. a development that originated from a *market point of view*<sup>2</sup>.

Adam Smith pointed out the advantages of the division of labour and specialization for a nail-making operation. He noted that there was an increase in dexterity in every workman. This enabled time savings gained by less frequent passing from one species of work to another, and the invention of or improvement in tools, methods, or machines facilitating labour and making it more efficient. These effects were more likely to occur in case of specialization.

---

<sup>1</sup> The *controller point of view* indicates changes in the required internal performance of the production system that make changes in the planning and control system necessary. The increased demands in terms of return on investments and the increasing influence of share holders result in such changes.

<sup>2</sup> A *market point of view* indicates the effect of changing market demands with respect to speed (lead time), dependability, flexibility, quality, and price on the design of the planning and control system.

Note that this type of worker specialization includes preparational, executionary, as well as regulatory aspects of the tasks. However, this further division of tasks made the co-ordination between the various tasks more complex. Charles Babbage (1832) noted:

*'The constant repetition of the same process necessarily produces in the workman a degree of excellence and rapidity in his particular department, which is never possessed by one person who is obliged to execute many different processes. ... Now the cost of keeping a stock of iron ore, or of coals above-ground, is just the same as that of keeping in a drawer, unemployed, its value in money (except, indeed, that the coal suffers a small deterioration by exposure to the elements). The interest of this sum must, therefore, be considered as the price of an insurance against the risk of combination amongst the workmen'*

Babbage showed that co-operation between workers who have specialized in a certain process has a cost. If one chooses to strive for the benefits of such specialization, appropriate design of the co-ordination system may lower the extra costs that are incurred. Babbage noted that there was a possibility of reducing the risk of combining processes, as this reduces the costs of manufacturing. He showed that the co-ordination system, i.e., the master manufacturer who distributes the work, was an instrument to reduce total costs. These planning system developments originated from both a *systems point of view*<sup>3</sup> and a *controller point of view*<sup>1</sup>.

The work of Taylor (1903) on shop management was a next step towards the development of production planning systems. He made a distinction between administrative and preparatory planning tasks and executionary planning tasks, and advocated the creation of a specialized planning function for the first set of tasks, so the foremen and workers could concentrate on the execution and realization of these plans. Furthermore, he abandoned the principle of 'unity of control', advocating a change from a strict hierarchical management control structure with one supervisor linking workers and management to a flatter control structure *'in which a worker receives his daily orders and help directly from eight different bosses, each of whom performs his own particular function'* (Taylor, [1903: 98-99]). His ideas instigated that the new production planning function owned a direct responsibility over the progress of work at the floor. The planner had to design the order release and control system such that the workers were able to work according to plan. Therefore, the system required that the output of the planning function -the plans- had to be very realistic. These developments led to a fundamental change from a *power balance point of view*<sup>4</sup>.

The introduction of separate planning departments and the application of scientific knowledge to the field of planning stimulated conceptualization of the relationship between efficiency, inventory, and production planning. Ford W. Harris (1913) was the first to publish a paper on

---

<sup>3</sup> A *systems point of view* indicates changes in the organization and integration of the technology in the production system that make it necessary to change the planning system as well.

<sup>4</sup> A *power balance point of view* indicates changes in the position and power of the planning office and in the task of production planning and control itself, resulting in changes in the planning system.

this relationship. He suggested the use of a mathematical formula in which the most economic choice for the order quantity would depend on cost factors, such as the costs of releasing an order to the floor, including the set-up costs, and the costs of carrying a large stock. This formula did not include all relevant factors, he noted, so it should be used by managers to check their own insights, and apply some correction factors if required. His economic order quantity formula is also known as Camp's Formula (Camp, 1922), or as Wilson's Formula (Wilson, 1934). The intended audience of the journal in which Harris published his formula consisted of managers in manufacturing. At that time it had some 10,000 readers, which shows that the development and application of scientific management principles had attracted broad interest. Since then, the application of statistical and mathematical models in the area of production planning has grown rapidly, a development, originating from a *theoretical progress point of view*<sup>5</sup>.

The next important step was made by Henry L. Gantt (1918), who developed charts for the detailed planning and monitoring of the production progress. The Gantt charts could be used in the planning room as a descriptive model of the controlled system. Such a model is one of the prerequisites for an effective control system, as noted by De Leeuw (1986). The development of these charts enabled the position of the planning room to change from mainly an administrative and preparatory one to a more proactive one in controlling the production system. The expected future loading of the resources in the system could be shown and this information could be used when deciding about the release of new work to the floor. The expected consequences of interventions by a manager in the production system (for example, if he planned to release a maintenance plan) could be visualized and communicated in advance to other parts of the system. This gave the production planning a central position in the operational control of the factory, and increased the power of the planners. Note that this development in the planning system originated from a *theoretical progress point of view*<sup>5</sup>.

However, the increased dependency on information systems such as Gantt charts for the control of production made the planning system more sensitive to errors or time delays in the information. This led to the development of administrative procedures for monitoring the progress of jobs, the availability of the required input material, the accuracy of the estimated times for setting up the machine and processing the jobs, the control of process outcomes in terms of yield and product quality, and so on. Many of the advancements were oriented towards the reduction of uncertainty, and statistical methods were developed in order to forecast demand and test the quality of production and input. All these measures were oriented towards making the deterministic model of the controlled system (the Gantt chart) a more accurate representation of the real system. These developments were necessary in order to preserve the position of the planning function from a *power balance point of view*<sup>4</sup>.

---

<sup>5</sup> A *theoretical progress point of view* indicates changes in the availability of planning methods, resulting in changes in the design of the planning system.

In designing an accurate model, the problem of aggregation and abstraction with respect to capacity and products appeared for the first time. Questions had to be answered: what products have to be included, should they be aggregated into families that are planned as one group, how should capacity be modelled, would it be necessary to model each capacity source separately, and so on. The decisions that were then made have had an important impact on the design of planning systems from a *theoretical progress point of view*<sup>5</sup>.

During this time, the period batch control system emerged, and it made use of the principle of parts explosion. This principle requires that products and parts be individually planned in order to generate balanced ordering sets. The enormous amount of data that had to be gathered and calculations that had to be performed forced the designers of the planning systems to search for stability in the overall plans, so plans would not have to be updated continuously.

As a consequence, planning efforts became hierarchically organized into several levels. In the first place, long term plans resulted that had to take into account such factors as seasonal demand, capacity changes, and so on. In the second place, short term plans resulted in which the actual production had to be planned. Here, the problem of aggregation with respect to time became apparent for the first time. For cyclical planning systems such as PBC, the length of the time bucket (the stable period) in both the long term and short term programs had to be determined. This choice had a direct impact on the amount of co-ordination effort required.

After the Second World War, the industrialized countries faced a steady increase in demand. Production facilities had to be rebuilt, as many had been destroyed, had deteriorated, or reconfigured during war time in order to supply the war industry. The modernization and rebuilding of society generated a multiplier effect that led to a strong increase in demand. At the same time, it was difficult to enlarge machine capacity by the required speed, due to scarce resources. The only way that production facilities could respond to the demand was to increase efficiency, enlarge batches instead of run frequencies, and provide longer throughput times. Buitenhuis and van het Nederend (1969) describe a cyclical planning system that in the early 1950s changed from a period length of one week to a period length of four months due to these market circumstances! This can be characterized as a development originating from both a *market point of view*<sup>2</sup> and a *resource point of view*<sup>6</sup>.

The type of planning system modification that has been sketched above (period length increase) is quite illustrative for the way systems were designed or redesigned. There was much attention to partial insights, but the effects on other parts of the system (inventory management) or other objectives (flexibility) were overlooked. Systems theory and, more specifically, industrial dynamics, did focus on the interrelationship between parts of a system and time varying behaviour. Jay W. Forrester (1961) studied dynamic systems with time-

---

<sup>6</sup> A *resource point of view* indicates changes in the availability of technology for the required transformation, which also requires a change in the way the system is being planned.

sequence relationships and showed the presence of amplification behaviour. He observed that the response of a part of a system to a certain change generally exaggerated the response that could reasonably be justified by the magnitude of the change. Such amplified changes could be observed in ordering behaviour in successive stages of the supply chain. The main causes for this nervous behaviour were found in (1) the length of the pipelines and hence the length of the time delay in the information feedback system, (2) the common but incorrect inventory policies that often were used, such as an upward tendency in the amount of safety stock if demand increased, and (3) the use of statistical forecasting techniques that assume that the historical demand patterns will prevail in the near future.

The literature on industrial dynamics has had an important impact on the design of planning systems from a *systems point of view*<sup>3</sup>. Monhemius (1989) notes that as a consequence, the old principles of period batch control, such as parts explosion, were reconsidered. These principles had resulted in ‘*one of the most sophisticated systems for goods flow control for complex products in the period before 1940*’ [1989:2], as they led to an integral control of the supply chain by using the information of end product demand in the control of each manufacturing stage.

Another development after World War II originated from a *theoretical progress point of view*<sup>5</sup> due to the growth in the field of operations research. Both the deterministic and stochastic aspects of production planning became objects of study, mainly for academic researchers. The role of consultants (such as Harris) who had been both developing and using scientific instruments changed. They became expert users of new knowledge. Some examples of these developments are queuing theory, general systems theory, linear programming (the simplex method), inventory theory, and scheduling theory. These theoretical developments have resulted in a large number of alternative planning systems for different production situations. For example, network planning theory for the planning of research and development projects, with their inherent task-time uncertainty, resulted in PERT (Program Evaluation Research Task (PERT, 1958), later known as Program Evaluation and Review Technique. Construction projects, with their inherent trade-off between realizing time objectives and cost objectives and the consequences for the usage of resources, were supported using CPM/Cost (Critical Path Method, Kelley & Walker, 1959). Scheduling theory was developed for job shop as well as flow shop production situations (e.g. Johnson, 1954, Muth & Thompson, 1963, and Conway, Maxwell, & Miller, 1967). However the distance between the developers of new theory and the proposed users of this theory rapidly increased. Many planning system designers were primarily users of this new theory, so a gap with mainstream operations research literature started to develop during the 1960s.

The growing insight into the need for integral control, and the theoretical progress in the field of forecasting and inventory models were important prerequisites for a new step forward in planning system design, but the contribution of the computer technology that became available at the end of the 1960s has to be seen as being the trigger for these developments.

Applying the developments that originated from an *information technology point of view*<sup>7</sup> made it possible to compute the expected demand for parts, calculate the required amount of raw materials, and co-ordinate the timing of release of work orders such that a successive process was fed without making it necessary to use huge amounts of either decoupling or buffer inventory. The systems were named Material Requirements Planning (MRP) systems.

The development of these computerized information systems reduced both the required time for and the costs of integral control. The need for integral control was interpreted as a need for central planning. This centralization empowered the planning and information functions in firms, and the newly obtained status had to be preserved through the application of advanced planning instruments that were made available from theoretical advances. In MRP systems, various options became available, often not well understood by the people who implemented these systems in firms or used these systems for actually regulating the goods flow in manufacturing systems. Some examples of these options are advanced lot-sizing rules for discrete demand, capacity planning, and so on. The application of such instruments made the system nervous, or resulted in unrealistic tasks being given to the floor because of the inherent weaknesses of the model of the controlled system that was behind the MRP system.

The developers of these systems (information system engineers) reacted by modifying the MRP concept into Closed Loop MRP and MRPII. However, modelling the control system in terms of important design parameters such as the offset lead time, bill of material structure, safety stocks, lot-sizes, was not paid the required attention by the information system engineers. The effect was that the quality of models of the controlled systems deteriorated, while the technical possibilities of more detailed control of the manufacturing system increased. In many applications, the combination of both effects made the industry very depressed about the competence of modern production planning systems. The result was a tendency to use the system only for administrative purposes, such as tracking and tracing, ordering materials, and so on. The role of such planning systems in actually controlling progress on the work floor is still limited, although no manufacturing system can nowadays operate without such a registrative and administrative ERP system.

In recent years, several important developments have taken place. The huge ERP systems are integrated with computerized graphical detailed scheduling systems (in Germany called *Leitstand systeme*) to improve the utilization of available system information in controlling the work flow. These systems are connected with systems for time measurement as well as simulation modelling tools in order to maintain an accurate model of the actual situation. The increased popularity of cyclical planning systems and visual control systems such as Kanban in recent years is a movement in the opposite direction. These systems are easier to describe, understand, and therefore better communicate the objectives and tasks to which the manufacturing system has to direct its attention. However, they do not rely heavily on

---

<sup>7</sup> An *information technology point of view* indicates changes in the availability of technology for supporting the required planning task, which enables a change in the planning system.

computer technology in controlling the work flow. Special attention has to be paid to the release of work to the production system and to the accurateness of the estimated throughput times and capabilities of the system. In repetitive production situations, level production schedules have been developed. For less predictive production and market situations, developments in the area of work load control systems have improved our understanding of the consequences of order release for system performance.

There are a number of parallel developments in the field of production organization that also have had important consequences for the design of planning systems.

The labour force has changed dramatically. There has been a strong increase in the education level of the work force, increase in their multi-flexibility, a tendency to temporarily use shift work as an instrument for increasing the flexibility of the firm, reduced working times per worker, an increase in part-time workers, higher participation of woman in production processes, the increased possibility of changing labour capacity in the short term by using employment agencies, and so on. All these developments have made it necessary to modify the production organization and its planning from a *labour force point of view*<sup>8</sup>.

At the same time, the increased automation of machinery and computerization of process control has changed the role of other parts of the system towards a more direct-service oriented one. The interrelationships between several parts of the system have changed as well as the demands that are placed upon the system in terms of efficiency, flexibility, dependability, and other types of performance. The decomposition of the planning system according to the (rather functionally defined) processing stages in the production system is hence not as appropriate as it was before from a *systems point of view*<sup>3</sup>.

Changes in machinery and set-up procedures have resulted in a change in the way capacity has to be planned. Conventional machinery would not take long to set up, but for newer machines, set-up activities have to be planned in a different way. The required precision and the availability of machine specific tools become more important in planning these set-ups. From a *resource point of view*<sup>6</sup>, planning systems had to take into account the co-ordination of these additional preparatory activities as well, besides the procurement of required materials.

Market forces have resulted in a demand for more variety, less repetition, smaller lead times, higher quality, and lower costs. From a *market point of view*<sup>2</sup>, this requires a better co-ordination of the activities that are involved both in translating the actual demands from a customer to the production organization, and in providing these demands.

Many production organizations have reacted to these demands from different viewpoints by delegating responsibility and authority to the work force, and redesigning the organizational

---

<sup>8</sup> A *labour force point of view* indicates changes in the composition and characteristics of the labour market.

units on the floor into cells or teams. The consequences of the increased autonomy of these units for the distribution of planning tasks in the production system are not clear. Some firms only allocate the detailed planning tasks to the units, other firms give units the authority to refuse work order packages that are proposed by the central planning, and so on.

The role and power of central planning probably changes because of these changes in responsibility and authority. From a *power balance point of view*<sup>4</sup>, we expect central planning to want to stay involved in determining the work order release packages, capacity analysis, and the co-ordination of the flows over the more or less autonomous units. However, the changing position and role of central planning puts other demands on the quality of the model they use to control the production system. This may have consequences for the required accuracy of data, and the degree of detailed knowledge about actual work order progress. The focus of the central planning systems may change, and this has important consequences for the architecture of production planning systems.

### § 1.2.2 Summary

We conclude that, besides changes from a theoretical progress point of view<sup>5</sup> and information technology point of view<sup>7</sup>, other factors have led to developments in the design of planning systems. An historical overview of developments in the field of planning systems design shows that there have been the following driving forces:

- The changing demands of customers with respect to speed (lead time), dependability, flexibility, quality, and price. The required external performance has led to changes in the planning system from a *market point of view*<sup>2</sup>.
- Changing internal performance requirements on the production system from a *controller point of view*<sup>1</sup>. Demands in terms of return on investments, and the increasing influence of share holders on the performance records have resulted in changes in the planning system.
- Changes in the labour market (the *labour force point of view*<sup>8</sup>), in the availability of transformation technology (the *resource point of view*<sup>6</sup>), and in the organization and integration of the technology in the production system (the *systems point of view*<sup>3</sup>), all have resulted in other demands on the planning system.
- Changes in the position and power of the planning office and in the task of production planning and control itself have led to changes from a *power balance point of view*<sup>4</sup>.

Changes in the design of a planning system should therefore not only reflect progress in information technology or planning theory, but also changes in organization and environment.

### § 1.3 Research questions

In the past, development of planning systems was strongly related to general organizational and technological development processes. We wonder to what extent the application of cellular manufacturing affects the design of production planning systems in organizations. The change towards cellular manufacturing is not primarily a technological change, but more an organizational change. Such a change has implications, and we ought to consider both the consequences and opportunities for planning system design.

Due to the introduction of cells, changes will occur with respect to the power of the planners in the organization, their relationship with cell leaders, communication and negotiating patterns, and so on. However, apart from these, we expect that the introduction of cells will have even more impact on the planning systems in firms, due to the change in the flows that will occur within the production system. In order to plan and co-ordinate these flows, we make a distinction between two levels of planning in a cellular manufacturing system: planning within cells and planning between cells. In this study, we direct our attention primarily to that part of the planning system that is responsible for the regulation of the various flows between cells in the production system.

The objective of this study is:

*to gain insight into the main factors that must be taken into account when designing a planning system for the co-ordination of flows between cells and their effect on system performance.*

The study will reveal what characteristics of a planning system should be taken into consideration for appropriate co-ordination between cells in a cellular organized production system. The relationship between production system design and planning system design affects the performance of the whole system. If we gain insight into the main design choices in planning system design and understand their relationship to production system design choices, we will be able to improve the performance of cellular manufacturing systems.

There is a huge variety in cellular manufacturing systems and planning system design choices. This variety has forced us to focus our attention on a specific type of cellular manufacturing system and also on a specific type of planning system.

We have chosen to restrict our attention to multi-stage cellular manufacturing systems, as we will examine the co-ordination between cells. Single-stage cellular manufacturing systems do not encounter intercellular flows. Our understanding of the main factors in planning system design for multi-stage systems will increase if we consider actual policies that are applied to planning and co-ordinating these cellular manufacturing systems. The practical situations that we consider in our study are mainly found in the discrete fabrication industry, especially in metal ware fabrication. The desired multi-stage characteristics were found in these situations.

Furthermore, we have restricted ourselves to one well-defined planning system that may be suitable for these cellular manufacturing systems. We examine which main factors should be considered when designing this planning system in the context of a multi-stage cellular manufacturing system. The choice for a specific planning system constrains the search process to suitable parameters for this system.

We have found one planning system that is both specifically proposed (Burbidge, 1971, 1996) and criticized (Hyer & Wemmerlöv, 1982) in literature for its suitability for supporting the overall planning in these multi-stage cellular manufacturing systems. Burbidge propagated the use of the *Period Batch Control* (PBC) system for these production situations because of the predictable throughput times, short lead times, low work in progress, and the clear distribution of responsibility. Hyer and Wemmerlöv criticized the PBC system for being too rigid and unsophisticated, but noted the influence of PBC system design choices on its effectiveness in multi-stage cellular manufacturing systems.

We require a well-defined planning system, but there are several variants of the PBC system described in literature. We have therefore decided to focus our study on a specific variant of this cyclical planning system, the *basic unicycle period batch control* system. The essential characteristic of this particular PBC system is its periodic, cyclical nature, where each work order has an identical lead time. It provides central co-ordination of the goods flow in a cellular system and synchronizes the transfer of work at fixed moments in time. It results in an intermittent, but predictable goods flow within the organization and in a transparent production plan.

The insights that we gain from examining this particular planning system will also be useful for designing other planning systems, whether cyclical or not. Characteristics of the PBC planning system do also appear in related planning systems such as MRP and Kanban. However, the latter systems require some additional design choices (e.g., lot-sizing decisions, internal lead times, container size, and capacity planning). These choices may distract attention from the main design choices in a planning system for cellular manufacturing. This makes these systems less suitable for our analysis.

There are three questions that we want to answer in this study:

- *What characterizes co-ordination between cells in a cellular manufacturing system?*
- *What are the main factors that distinguish the basic unicycle Period Batch Control system from other planning concepts in supporting these co-ordination requirements?*
- *What choices have to be made when designing a basic unicycle Period Batch Control system for the co-ordination between cells and how do they affect performance?*

The study aims at a specialist audience of people involved in the design or redesign of planning systems, both from academic institutions and from industry. It supposes elementary knowledge of logistics and production planning at APICS CPIM level, which can be obtained by studying, for example, the introductory text of Vollmann, Berry and Whybark (1997). However, the results of this study should also convince other people involved in the redesign of production systems of the relevance of considering a suitable reconfiguration of planning systems in order to obtain the benefits that are aimed at in the redesign project.

Ultimately, the study wants to show that in the redesign of both production organization and planning system a careful trade-off should be made in order to realize a higher performance by the system as a whole.

## § 1.4 Outline of thesis

Our study focuses on that part of the planning system that is responsible for regulating the co-ordination between cells. It is therefore directed towards logistical co-ordination requirements in the system.

Chapter Two examines the first research question. It describes the impact of an organizational change towards cellular manufacturing on the logistical co-ordination requirements between cells. We present an instrument to describe the various relationships between cells that may occur. This instrument is used to analyse five case studies involving Dutch firms that use cellular manufacturing in their small-batch metal ware fabrication. We identify various types of relationships between cells and show how these firms co-ordinated these relationships. Finally, we discuss the implications for planning system design.

Chapter Three studies the second research question. It analyses the basic unicycle period batch control system and addresses the essential principles of such a system that distinguish it from other planning concepts. It discusses the major differences with other PBC systems as well as other planning approaches, such as material requirements planning and Kanban. Finally, it introduces our last research question on the design choices in such a system.

The third research question is answered in Chapters Four to Eight.

Firstly, Chapter Four discusses the relationship between the structure of the production system and the design of the basic unicycle period batch control system. We examine the influence of both the definition of stages and the length of the period on the performance of the manufacturing system. This will reveal whether the application of a cellular manufacturing system can be more successful if combined with an appropriate design for a period batch control system.

Chapter Five provides support in the determination of a period length in such a period batch control system. For this purpose, it develops mathematical models and several heuristic solution approaches.

In Chapter Six, the effect of the design of a PBC system on performance is further elaborated through a trade-off analysis with respect to PBC design parameters: period length, number of stages, stage contents, and number of transfer batches. We apply simulation analysis to determine the effect of various combinations of design parameters on the performance of a PBC system, and test the sensitivity of this performance for changes in product structure and market characteristics. We perform this analysis for a cellular manufacturing system that has been described in literature.

Chapter Seven explores the applicability of the solution methods of Chapter Five for PBC system design parameters in the simulated system of Chapter Six. It provides a design approach for the integral design of the production and PBC planning system.

Finally, Chapter Eight studies the relationship between PBC design and the required co-ordination in the cellular manufacturing system. If an organization applies cellular manufacturing and uses PBC as an overall planning system, the design of the PBC system influences the distribution of co-ordination requirements in the system. In order to analyse this distribution, it makes a distinction between co-ordination within and between cells. Finally, for specific PBC system design choices, it proposes an intermediate hierarchical planning level between the central co-ordination performed by the PBC system and the decentral co-ordination that is performed within cells. This intermediate hierarchical planning level is denoted 'stage co-ordination'.

Chapter Nine recapitulates the conclusions of this study and provides suggestions for further research.



---

## Chapter 2 Relationships between cells in cellular manufacturing

Firms that wish to apply cellular manufacturing have to understand the different characteristics of the planning problems they will face. Literature reports that many cellular organized firms face problems with the support given by their production planning systems. Wildemann (1992) noted that 56% of the firms that had adopted a cellular decomposition of their production system had not significantly modified their method of planning and controlling the production system. This is remarkable, as many of the expected benefits of a change to cellular manufacturing are logistical in nature.

Olorunniwo (1996) reported from a survey of US firms the differences in application of planning and control systems before and after the introduction of cells. He found that before cellularization, 74.6% of the firms used an MRP system, and after cellularization, 70.9 % used this system, sometimes in combination with another system for control of a part of the system (e.g., within the cell). Still, 60% of the firms that used MRP had not changed their method of planning and controlling the system at all.

According to Burbidge, Partridge and Aitchison (1991), the main benefits that can be expected from a change towards cellular manufacturing are substantial reductions in material throughput times and material handling, improvements in quality and accountability, better trained workers, higher job satisfaction, and a production system that is better prepared for future process automation. Other benefits that are often mentioned are higher delivery performance, lower work in progress, easier loading, and a higher volume and mix flexibility.

Many authors see as one of the reasons for these benefits the simplification of the planning and control problem, see e.g., Kuipers & van Amelsvoort [1990: 103]. They assume that the delegation of planning tasks and responsibilities to cells leads to an easy to accomplish overall co-ordination of the goods flow in cellular manufacturing systems. A good hierarchical decomposition of the planning problem makes the co-ordination issue within cellular manufacturing easily tractable.

In this chapter, we question if this is not a far too simple view of the co-ordination issue within cellular manufacturing. Therefore, we will analyse the requirements for the planning system that originate from a cellular decomposition of the production system. We restrict ourselves to the kind of co-ordination<sup>1</sup> that is needed *between* cells, because our study focuses on planning system design for multi-stage cellular systems. We develop a framework for analysing the co-ordination requirements between cells.

---

<sup>1</sup> Note that in our terminology, co-ordination belongs to the task domain and responsibility of the planning system, but need not be performed by using computerized tools and methods for planning and control. The planning system is much broader defined than this set of tools and methods. Moreover, co-ordination is not restricted to planning in a narrow sense, i.e. prescription of the way of performing the transformation in advance, but includes various types of mutual arrangements.

We use this framework in our analysis of the case studies. These studies have been performed in five firms that use cellular manufacturing for their production of parts. Characteristics of the case studies and their cellular organization are described in Appendix A. We will describe the specific co-ordination requirements that resulted from their cellular decomposition. Note that all firms are involved in small-batch metal ware fabrication. The cells they implemented are mostly hybrid cells with functional layouts within the cells, instead of flow-line layouts.

The chapter is organized as follows. Section § 2.1 presents an overview of the literature on relationships between cells. Section § 2.2 presents a comprehensive description of co-ordination requirements. It introduces three types of relationships between cells: sequential, simultaneous, and latent relationships. The description of these relationships serves as a framework for analysing the planning between cells. Section § 2.3 shows for the five cases the differences in both the presence of the sequential, simultaneous, and latent relationships, and in the way they are coped with. Section § 2.4 ends with conclusions on the use of this framework for analysis.

## § 2.1 Literature on relationships between cells

We have defined a cell as *an organizational unit consisting of a set of resources (workers, equipment, and information) that is able to process several operations per work order*. Cells operate as elements in a system. We consider this manufacturing system as an open system, which implies that we examine the interaction of cells with other parts of the system as well as with elements in the environment of the system. The system boundary decision indicates that it is useful to distinguish the interaction with other elements within the system and the interaction with elements in the environment, such as a subcontractor. Both from a contractual and from an organizational point of view the usefulness of this distinction is clear.

We examine the relationships between elements of the system (i.e., cells, remaining cells) that are relevant with respect to the co-ordination requirements in the transformation process. The transformation process consists of all conversion activities or operations required to produce the desired products and services. A cellular manufacturing system is decomposed into several cells that all perform a subset of these operations.

Relationships between cells can be identified by examining the interdependencies between these elements in the system. Thompson (1967) introduced three types of interdependencies between elements in a system: pooled, sequential and reciprocal interdependencies.

Two elements in a system are *pooled interdependent* if they both contribute to and are sustained by the overall system. This type of interdependency between elements is only indirect in nature, as each element can provide its contribution to the system independently, but for the success of the system, both will have to succeed in their contributions.

Pooled interdependent elements are also *sequential interdependent* if one of them provides input for the other. Sequential interdependency points therefore towards a more direct relationship and interdependency between the elements in a system. The output of one element may affect the other element.

If both elements are sequentially interdependent with respect to the same process, their interdependency is *reciprocal*, causing more complex co-ordination requirements between these elements. Figure 2.1 shows the relationship between the three types of interdependency.

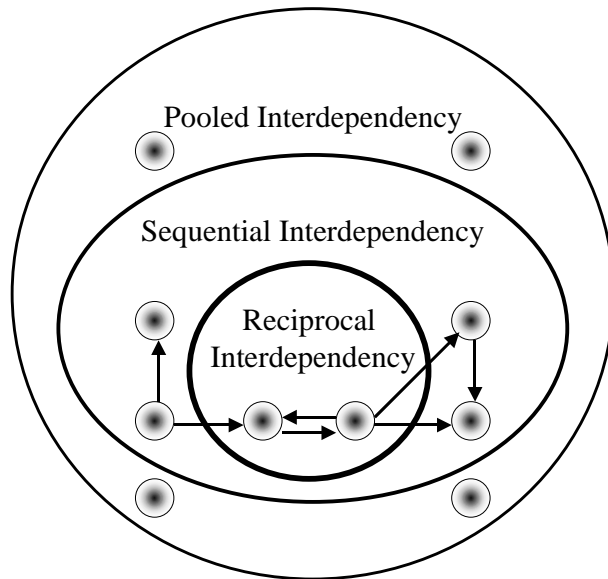

**Figure 2.1 Interdependency between system elements**

The interdependencies that are introduced by Thompson are useful in identifying a relevant aspect of the nature of the relationship between cells. He uses these interdependencies to identify an effective grouping based on the co-ordination requirements between the elements. According to Thompson, reciprocal interdependency requires co-ordination by mutual adjustment, which makes it necessary that elements in this set are clustered. If the size of the cluster becomes too huge for effective communication, he suggests to use an extra factor for finding subgroupings: the amount of contingency that one system element poses for another.

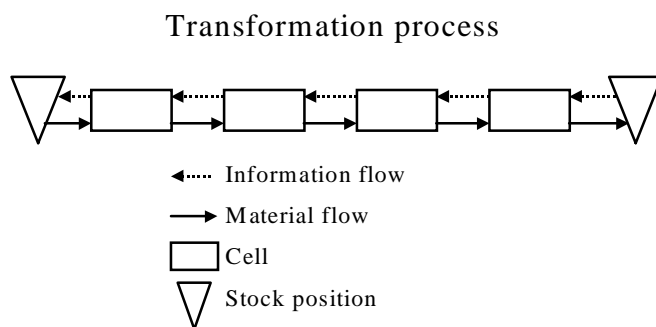

**Figure 2.2 Reciprocal interdependency between cells in transformation process**

Thompson's notion of interdependency does not enable us to identify the actual co-ordination requirement between cells for an effective control of the transformation process. The reason is that all cells in the transformation process are pooled interdependent, as they all contribute to the same organization. If cells are sequentially interdependent, they often will also be reciprocal interdependent because of the parallel but opposite directed flows of material and information necessary to proceed with the same transformation process, as Figure 2.2 shows. Note however, that the frequency of interchange of these flows need not be the same, nor the consequences of an inadequate co-ordination of these flows. We should therefore further distinguish the interdependencies between cells that are reciprocal interdependent according to the definition of Thompson and identify their co-ordination requirements more precisely.

Susman (1976) introduced two types of interdependency between group members in a cell, based on parallelization and segmentation of their tasks. We will use this distinction in order to refine the notion of interdependency between cells. Susman considered the situation where two group members perform the same task in parallel within a period of time. They have a simultaneous-*independent* relationship, and the reason for this relationship is the scarce amount of time. If more time would have been available, the work could have been completed by only one person. Now they may have to cooperate, and share tools, space, or information. The reason for the other type of interdependency is task segmentation. In that case, a sequential-dependent relationship occurs for the limiting factor is the *skill* of the operators. If one operator was able to perform all necessary operations on this work order, the work could have been completed by this one person. Hence, segmentation is required because of scarcity of skill; parallelization is required because of scarcity of time.

We can extend these relationships to the interdependency of cells. If two cells are able to perform the same task, we may use this (latent) relationship when determining an efficient loading of the whole system. Furthermore, if two cells perform simultaneously (possibly different) tasks that later in the transformation process (e.g., in an assembly stage) are combined, the time-limited aspect of the relationship between these cells may be used in designing a more effective co-ordination of the whole transformation process. Finally, we consider a sequential dependent relationship between cells, as segmentation of the product flow is an essential characteristic of a multi-stage cellular manufacturing system.

Much of the literature on the design of cellular manufacturing systems stresses the importance of avoiding sequential dependent relationships as much as possible. Many procedures for the design of a cellular decomposition try to transform the part/machine matrix into a block diagonal form<sup>2</sup> (see for an overview Miltenburg & Zhang, 1991, Vakharia & Wemmerlöv, 1995). Garza and Smunt (1991, 1994) even state that the main benefits of dedication in a cellular system are lost if intercell flow of material is allowed. However, segmentation may be

---

<sup>2</sup> We think it is an omission in literature on cell design that no methods are available that support the transformation of the part/machine matrix into a form that finds a good decomposition and segmentation of the system into a multi-stage cellular manufacturing system.

necessary due to the scarcity or nature of the technology used. Segmentation may also be intentionally designed into a cellular manufacturing system, even when the above mentioned factors do not make it unavoidable. In order to understand this, we have to return to our definition of cells<sup>3</sup>. Literature generally assumes that the selection of a combination of operations that a cell can perform should enable it to produce a fixed product family. The cells are then dedicated towards this family, and flows of material between cells are avoided. However, avoiding material flows between cells results only in a subset of all benefits of cellular manufacturing. Other benefits, such as short throughput times, increased job satisfaction, and reduced quality problems, may be as important and need not only be obtainable through the dedication to a fixed product family. According to Alford (1994), we can distinguish two types of dedication in cells. Cells can be dedicated to:

•	a fixed product family	cells get the disposal of all <i>resources</i> necessary to perform the required operations and complete this family
•	a fixed combination of operations	cells get the disposal of <i>products</i> that require a subset of the available set of operations

The impact of this distinction becomes visible if a design change occurs for one of the products allocated to the cell such that a new type of operation is required for this product. This situation is depicted in Figure 2.3. Type 1 cells will add resources for this new operation to the cell, in order to let the cell remain dedicated to the same product family, as shown in the upper right part in Figure 2.3. Type 2 cells will redesign the routing of the product, such that the redesigned product visits another cell for the new operation. The set of operations allocated to the type 2 cell remains the same, as shown in the lower right part in Figure 2.3.

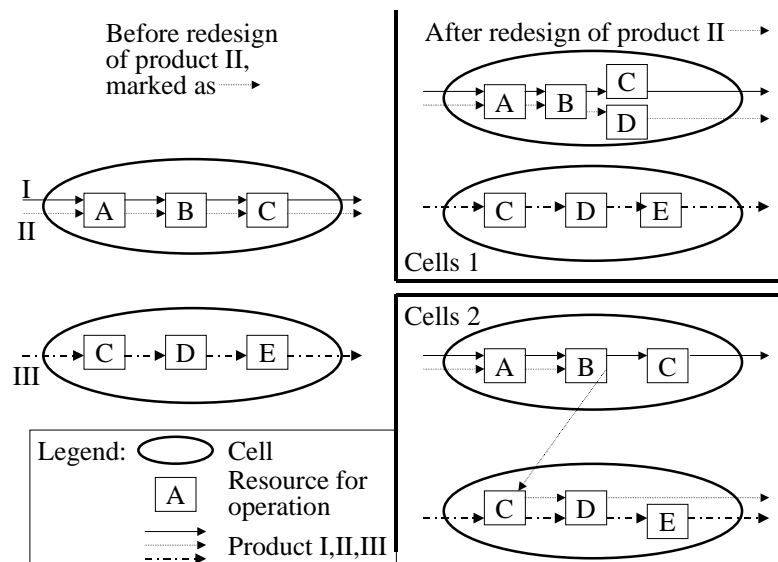

Figure 2.3 Product redesign with cell dedication types 1 and 2

<sup>3</sup> We have defined a cell as an organizational unit consisting of a set of resources (workers, equipment, and information) that is able to process several operations per work order.

In the second type of cells, the benefits of dedication are not expected from the avoidance of flows between cells in the system, but from the specific combination of operations and hence resources in the cells. These benefits may be found in an increased variety and attractiveness of work and a better work load distribution over the cells. The reduction of material flows between this type of cells is then not an objective from a systems design point of view. Note that this distinction between cells does not concern cell layout, but only the relationships between cells. The type of dedication of a cell causes different relationships with other cells.

Burbidge (1993) distinguished between *cross flow* and *back flow* relationships between cells and used the notion of ‘processing stages’<sup>4</sup> in describing these material flows. We view a cross flow as a relationship between cells at the same processing stage due to the flow of material, and a back flow as a flow of material from a cell to another cell that belongs to a preceding processing stage. The main goods flow follows the direction of the processing stages. Burbidge stated that if cross flow relationships are allowed between cells, throughput times, stocks and handling costs will increase, quality control will be more difficult, and it will be impossible to hold the cell responsible for quality, cost, and completion by due date. Still, several reasons can exist to accept cross flow relationships or even back flow relationships between cells, at least temporally. Burbidge mentioned two main reasons:

- to support a quick change to group technology
- to accommodate design modifications or introduce new products

The difference in complexity of the relationships between cells can become a useful distinction in planning system design. Dale and Russell (1983) report on the redesign of a machine shop and distinguished between simple cells and complex cells, according to the complexity of the material flow relationships between them. They placed the simple cells in line such that only simple sequential material flow relationships between these cells remained. Therefore, these relationships could be controlled using a simple co-ordination mechanism directed to obtaining the benefits of cellular manufacturing. The complex cells were designed such that interchange of work from one cell to another was possible, leading to more complex material flow relationships between the cells. Interchanging work orders between these cells resulted in balanced queues of parts. This enabled them to meet fluctuations in market demand. So together the complex cells had high mix flexibility. In this way, short throughput times could be guaranteed while producing with an overall acceptable utilization rate.

Willey and Ang (1980) showed that changes in part mix and volume can result in an imbalance in workloads between and within cells. In the case of complex cells (that are not completely disjoint), these problems were mitigated by transferring workloads between cells. They used these relationships between complex cells in the control of the production. Several heuristics were tested and the results of their simulation experiments showed that the decision

---

<sup>4</sup> Burbidge [1996: 258] defined a processing stage as ‘a stage in processing at which batches must be completed before forwarding them to the next operation’. He considered four stages: prefabrication (material production), fabrication (component processing), finishing (painting) and assembly.

when and to which alternate machine centre workloads are being transferred can have significant influence on shop performance.

It can be highly efficient and attractive to use this flexibility and consider the specific relationship between these cells in the planning and control of the cellular manufacturing system. However, we should recognize that the possibility of using this type of relationship between cells generates specific co-ordination requirements in the system. The required co-ordination does not only concern the control of the flow of material between the cells, but also the decision when and to which cell the transfer of workload has to take place.

From this literature survey, we conclude that there are several valid reasons for the existence of material flows between cells. We can summarize these reasons as:

- scarcity of skills
- nature of technology
- benefits of dedication to a fixed combination of operations:
  - increased variety and attractiveness of work
  - better work load distribution over the cells
- support quick change to group technology
- accommodate design modifications or introduce new products
- both simple and flexible planning system
- less sensitive to work load imbalance

However, the co-ordination requirements between cells should not be restricted to the material flow relationships, but other types of flows between cells and the available flexibility between cells should be considered as well. A consequence of neglecting these relationships is a too restricted view of the required co-ordination effort in cellular manufacturing. In order to improve the identification of relationships that require co-ordination, we need an instrument that helps us to describe several types of relationships between cells. Although the importance of considering relationships between cells is recognized in the literature, no instrument is available that provides a comprehensive description of the existing relationships between cells and their co-ordination requirements. In the next section, we present such a categorization of relationships.

## § 2.2 Sequential, Simultaneous, and Latent relationships between cells

In this section, we focus on the identification of relationships between cells and the co-ordination necessary to proceed with the primary transformation process of the production system. Note that the presence of orders in the system causes these relationships to occur and therefore induces the co-ordination requirement between cells. The type of relationship provides information on the extent of the co-ordination requirement between the cells. We can use this information when designing co-ordination mechanisms for the planning system.

Co-ordination requirements can exist with respect to three types of relationships between cells: sequential, simultaneous, and latent. We will first introduce these relationships formally and afterwards we work them out.

A **sequential relationship** between two cells exists if a directed flow between the cells is prescribed<sup>5</sup> in order to proceed with the primary transformation process of the system.

We distinguish between sequential relationships due to the existence of:

- a prescribed *material* flow between cells
- a prescribed *resource* flow between cells
- a prescribed *information* flow between cells

A **simultaneous relationship** between two cells exists if it is prescribed<sup>5</sup> that activities that have been allocated to these cells can be performed in parallel. The activities must be needed to proceed with the primary transformation process of the system.

A **latent relationship** between two cells exists if a sequential or simultaneous relationship between the cells can be created by using the available flexibility in assigning operations, resources, material, or information to both cells. A relationship between two cells is latent if:

- the prescription of either the flow or the parallel connection between these cells has not yet been completed. This is the case with incomplete specification (process plan) or allocation (production plan) of the required operations, resources, material and information to the cells
- an alternative in the already prescribed flow or connection between cells is present with respect to this specification and allocation of operations, resources, material and information

The next two types of alternatives cause a latent relationship between cells:

- existence of an *alternative cell* that can be involved in the plan; the cells are related because the alternative cell can also perform the required operation, and may have to use the resource, material or information to proceed with its primary process
- existence of an *alternative sequence* in which the cells are visited to perform the operation, or will have the disposal of the resource, material or information

The existence of the various relationships depends on the set of accepted work orders<sup>6</sup> that are to be produced. Relevant characteristics of these orders are used to determine possible specifications and allocations of the corresponding operations to the cells. This results in a set of process plans and an aggregate production (allocation) plan. The information contained in these plans is sufficient to determine between what cells which relationships will exist.

---

<sup>5</sup> This has to be prescribed either in a process plan or a production (allocation) plan.

<sup>6</sup> A work order is defined as the most comprehensive set of specified requirements of one (internal or external) customer to be met by the system, where the specifications include the type of products and the amount, quality and delivery aspects.

### § 2.2.1 Sequential relationships

Sequential *material* flow relationships can be split into relationships caused by the segmentation of the main goods flow, and either incidental or structural deviations from this flow. This distinction is important from a co-ordination point of view, as it can have impact for the way the corresponding co-ordination requirements are coped with. Incidental or structural intercell movements that deviate from the main goods flow are easily identifiable in a cellular manufacturing system. These intercell movements are between machines or cells at the same or a former processing stage (see for a definition of processing stage footnote 4). In a cellular manufacturing system, the percentage orders that need such intercell movements is generally small. This may make it possible to co-ordinate the flow of orders that need such intercell movement with another co-ordination mechanism then used for co-ordinating the main goods flow.

The second type of sequential relationship originates from the flow of *resources* between cells. If it is prescribed that a cell requires a specific resource for use in its transformation process, and this resource is first used in another cell, there exists a sequential relationship between these cells. Examples of such resources are cutting tools, fixtures, transportation equipment, but also human operators that have to be interchanged between the cells.

The last type of sequential relationship that we consider is a relationship between two cells due to the prescribed delivery of *information* from one cell to another. If this information is not given to the cell, it cannot proceed with the primary activities that have to be performed. Therefore, these cells are sequentially dependent.

It is important to distinguish information flows needed due to a sequential dependency and information flows needed for controlling the primary process. The first type is considered here and it includes such information as order documents, processing and measuring instructions (e.g., NC programs), measurement reports, etc. The flow of this information will often be combined with the flow of material or resources from one cell to another. In that case, no new relationships between the cells result, although the information flow does generate a co-ordination requirement. However, the flow of information need not be combined with one of the other flows. It can generate a sequential relationship between cells on its own and hence create a specific co-ordination requirement.

Concluding, we want to stress that two cells can have a sequential relationship while never delivering material to each other; flows of resources and information also generate sequential relationships.

### § 2.2.2 Simultaneous relationships

Simultaneous relationships can be encountered if two cells perform activities for the same order. They are not related through a material or resource flow, but through an information flow with respect to this order. The information they have to share is not required in order to proceed with the transformation process, but the cells benefit from sharing the information. Simultaneously related cells share information, e.g. on the progress of their activities or on the liability of the customer. Suppose that several cells produce for the same assembly. A cell might benefit from obtaining information on the delivery dates that the other cells can guarantee. The planning within the cell could possibly benefit by using this information of the simultaneously related cells. If one of the cells has a machine breakdown that delays its production of parts for an assembly, a simultaneously related cell will not need to give priority to a component for the same product. Sharing the available information on progress or due dates makes it possible to update the planning of all simultaneous cells. Note that the *sequentially* related assembly cell itself will not benefit from sharing this information between the *simultaneously* related fabrication cells.

Simultaneous relationships can also occur due to specifications in a process plan, concerning, for example, the raw material that has to be used, or the time frame in which both operations in the different cells have to be performed. Sharing information between these cells on the related activities they perform makes these cells simultaneously related.

Our definition of a simultaneous relationship between cells is not identical to the simultaneous-independence relationship as introduced by Susman (1976). In his view (which we described in Section § 2.1), two elements are only simultaneously related because of the lack of time, which forces them to perform the task in parallel. In order to increase capacity for this task, the simultaneous dependency between several elements should be identified, as they probably will share some resources, require the same type of materials, and so on. This increases the complexity of co-ordination in the system. We do consider these complex flows, but denote them as additional sequential relationships between the cells.

Our definition of a simultaneous relationship between cells is neither identical to a pooled interdependency as introduced by Thompson (1967). The information flows between simultaneously related cells makes their interdependency either sequential or reciprocal. However, the way we organize the co-ordination of these flows needs not be the same as for other sequential relationships between cells, because of the frequency of occurrence, and the different consequences of not obtaining this information.

§ 2.2.3 Latent relationships

Latent relationships between cells are defined in a more abstract sense. They exist if flexibility is available within the production system that can be used to create or change a sequential or simultaneous relationship between the cells.

An important type of latent relationship can be found in the presence of a *pool of shared resources* (see Figure 2.4). These resources are not allocated to specific cells, but a cell requires the disposal of such a resource for a specific operation. The flow of shared resources is often not planned, and the time at which the resources are really needed by the cells is frequently not known to the planning system. This makes it possible that conflicts between cells arise if more cells want to have the disposal of one of these resources at the same time. Cells are latent related if this can occur, e.g., if a specific resource can be claimed by both cells for the production of the set of currently known orders. For the existence of a latent relationship between two cells it is not necessary that the shared resource will be interchanged between these cells, as is required in case of a sequential resource relationship between these cells.

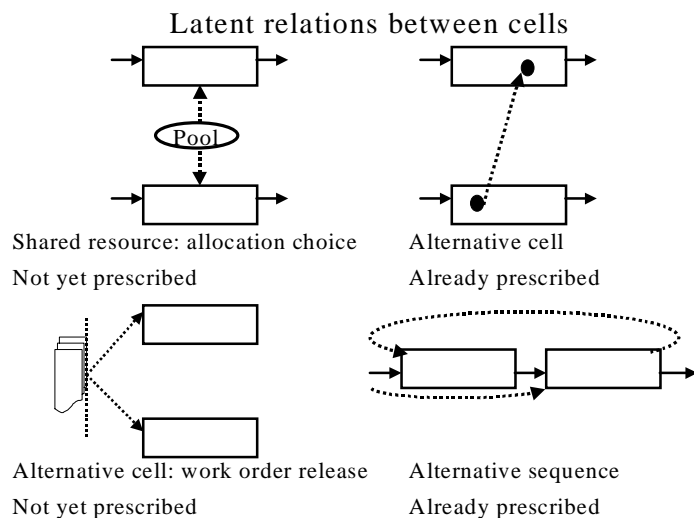

**Figure 2.4 Latent relationships between cells**

The second type of latent relationship is caused by the available flexibility between cells in the already determined specification and allocation of operations, resources, material and information. So this type can be encountered if it is possible to specify and prescribe an alternative process routing for an order by using another cell instead of the current one, in that way creating a latent relationship between these cells. This can only occur if both cells are not completely disjoint, which happens quite often in parts production due to the allocation of similar machines to the various cells.

Figure 2.4 shows four latent relationships between cells. If a plan not yet has prescribed the sequence of the flow (of a shared resource, work order, or information), the co-ordination requirement is that a choice should be made. However, after a choice has been made, the cells remain latent related, as long as there remains some flexibility with respect to this allocation decision. Both relationships are latent, but the co-ordination requirements are different.

Our categorization of relationships between cells makes a distinction between sequential, simultaneous and latent relationships. These categories can be used as a framework for analysing the co-ordination requirements between cells in a cellular manufacturing system. The second part of this chapter illustrates the usage of this framework in five case studies.

### § 2.3 Relationships between cells in practice

In this section, we show the usage of the distinction between sequential, simultaneous, and latent relationships in determining co-ordination requirements between cells in a practical context. The five case studies were all found in Dutch metal ware small batch production. The characteristics of these firms and their cellular organization are introduced in appendix A. In this paragraph we will describe relationships between cells in the part production processing stage with other elements in the system. We focus on situations where the distinction in relationships between cells helped us to detect co-ordination requirements and we tried to identify which co-ordination mechanisms were applied by the five firms in order to cope with these relationships. We do not aim at presenting all relationships that existed between these cells in the cases we studied. A selection of these relationships will show the usefulness of the framework that we developed.

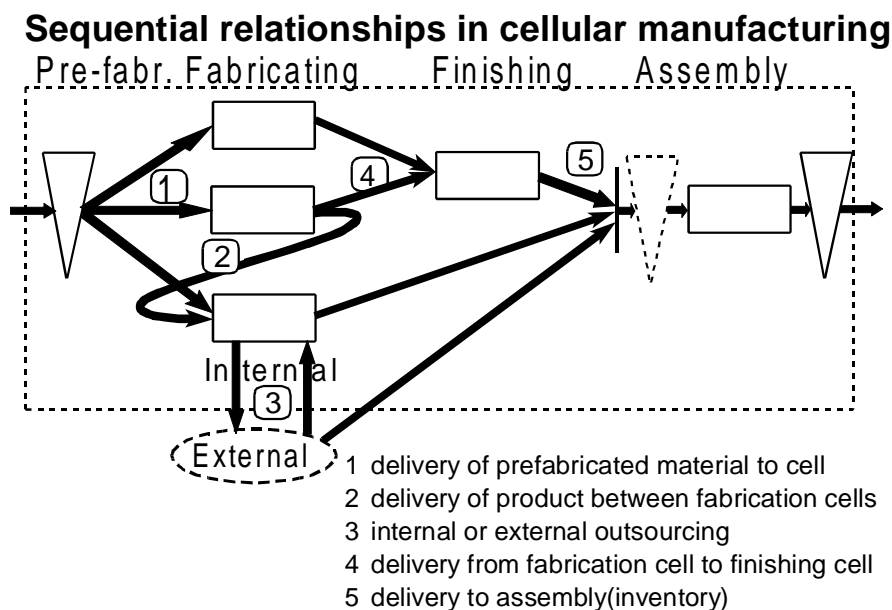

**Figure 2.5 Five types of sequential relationships with a cell**

## § 2.3.1 Sequential relationships

We deal with five types of sequential relationships as illustrated in Figure 2.5 and show the differences in coping with these relationships between the cases.

The *first sequential relationship* that we examine is between a prefabrication cell and a parts-producing cell. In all cases raw material was centrally prefabricated in a cell that also performed the warehousing function and often even tool management (e.g., storage, preparation, pre-setting). However, the pull or push mechanism that was used to control the delivery to the parts-producing cell differed per firm, as can be seen in Table 2.1.

Case	I Complex machines	II Complete installations	III Complex installation	IV Parts production make/engineer to order	V Parts production make to order
Push/Pull	push	pull	push	push	pull
Max. lead time	1 day	4 days	no max.	no max.	2 days

**Table 2.1 Sequential relationship with prefabrication cell**

Two cases used a pull system to control this delivery to the parts-producing cells, which means that orders were released to the parts-producing cell and that prefabrication could only start if the parts-producing cell had handled the material request to prefabrication. The other three cases used a push mechanism, so orders were first released to the prefabrication cell. This cell prepared the required material and either reserved it for or delivered it directly to the parts-producing cell. The available time for this operation was explicitly restricted in three cases. The decision to use a pull or push mechanism has consequences for both the total amount of work in process and the efficiency that can be achieved in the prefabrication cell. Note that a pull system creates additional sequential relationships between the cells in the direction opposite to the material flow because of the required information flow from the parts producing cell to the prefabrication cell.

The *second sequential relationship* concerns a relationship between a parts-producing cell and a cell at the same or a former processing stage, i.e. a cross or back flow. If this relationship is present, the way it is coped with interests us. Table 2.2 presents the relationships we found in the cases studied and the policy with respect to the use of this relationship.

Case	I Complex machines	II Complete installations	III Complex installation	IV Parts production make/engineer to order	V Parts production make to order
Former stage	not present	not present	present	not present	not present
Same stage	present	present	present	present	present
Usage frequency	incidental	incidental	structural	structural	structural

**Table 2.2 Sequential relationship with a cell at the same or a former processing stage**

As can be seen in Table 2.2, all firms encountered this type of relationship between cells, mainly within the same stage, but the way they coped with it differed. Case I and II used this relationship incidentally, e.g., in case of a machine break down, by switching the work temporally to another cell. They preferred to subcontract the work to avoid disturbing the processing in the other cells instead of structurally using this flexibility. Generally, the load of the other cells prohibited the interchange of work, as the interchange of work would delay orders that had already been released to these cells.

The other three cases encountered these relationships structurally. Case IV and V designed their cellular system such that no more than 10%-20% of the orders had to be processed sequentially in more cells at the same stage. Both firms considered this percentage unavoidable, as duplication of the required resources was economically not justifiable. The co-ordination of this relationship was a problem in case IV, where the cell that performs the first operations is held responsible for the final delivery performance of the order. If this cell transfers the work to the next cell, the latter is often not willing to give priority to orders for whose delivery performance they are not responsible. A reason can be found in the resulting machine load not being taken into account in the planning of the second cell, i.e. in the capacity profiles made for this cell.

Case III had both structural relationships with cells at the same and at a former processing stage. These relationships were for a large part caused by the processing sequence of one module. After pre-processing has taken place, this module is processed in the welding cluster and afterwards the mechanical cluster is involved before it is put in stock. However, the flow between the welding cluster and the pre-processing cell is bi-directional. When the last welding operation is completed, the module is first returned to the pre-processing cell that also performs some finishing operations. The required inspection of the finishing work is again done within the welding cell. The firm preferred this relationship in the main flow because (1) the utilization of the finishing machines was too low to create a separate cell, (2) the finishing work was considered too simple for performing it in the welding cell, and (3) the skill level of the finishing operators was comparable with the prefabrication operators.

The *third sequential relationship* describes the existence of relationships with other elements in the system or its environment due to operations that are performed by an internal or external subcontractor. An example of an internal subcontractor is a quick service or a separate machine within the shop used by more cells. External subcontracting means here the subcontracting of part of the work that had already been allocated to a cell. It can be used for capacity reasons or because the required operations cannot be performed within the firm, which is often the case with surface or other finishing operations. It is important to describe the flow of material after the subcontracted operation has finished. Is it to be returned to the parts-producing cell to continue processing or is it to be delivered to the warehouse? This affects the way to cope with the co-ordination requirements.

Case	I Complex machines	II Complete installations	III Complex installation	IV Parts production make/engineer to order	V Parts production make to order
External capacity	incidental	structural	incidental	incidental	incidental
Surfacing: work returned to	cell	warehouse	warehouse	NA	warehouse
Internal	NA	NA	heating	NA	quick services

**Table 2.3 Sequential relationship with subcontractor or internal separate department**

Table 2.3 presents an overview of this third type of sequential relationship in the five cases. The first row describes the usage that is made of external subcontracting due to capacity reasons. In all cases but one, the surfacing operations were externally subcontracted. The second row describes the return flow of material after the work had been subcontracted for a surfacing operation. If (part of) the work is returned to the parts-producing cell, it is denoted by *cell*, otherwise by *warehouse*. The last row describes the presence of internal subcontracting to a separate department.

Subcontracting work that had already been allocated to a cell due to capacity reasons was in most cases restricted. Only one case used this form of flexibility intensively. The cell foreman was allowed to decide on his own about subcontracting work. Subcontracting due to these capacity reasons was here often preferred to changing the planning of the cells by reallocating the work, and adequate procedures for subcontracting had been developed. For example, the cell stays responsible for delivering the correct information, material, and tools (if necessary), and for the lead time performance on the subcontracted order. Much of the production flexibility in the firm was found in this subcontracting system with near door subcontractors. This resulted in a very high utilization of the cells, as frequent disturbances caused by the transfer of work load between cells were avoided.

If the flow of subcontracted material is directly returned to a cell for further processing, the cell ought to be informed about the arrival of the work, which results in a sequential relationship because of an information flow. Provision of information with respect to the expected return moment of the subcontracted work would enable the cell to make a realistic planning of the resulting work load. Case I did not use planning as a co-ordination mechanism for this relationship with the external subcontractor. Instead, it used a large amount of slack time. In most of the cases, the work was returned to the warehouse and the planning department allocated the work to a cell if further processing was necessary.

Two of the cases used sequential relationships with separate internal departments. The handling of these flows was done differently. In case III the internal transport system was used, while in case V the cell who had to continue processing brought the material to the departments.

The *fourth sequential relationship* is between a parts-producing cell and a finishing cell. This relationship is especially important if more parts-producing cells have this relationship with one finishing cell. A finishing cell can often process only one arrival at a time and is usually the last cell involved in producing the order, so the lead time performance of this cell is very important. We describe the type of co-ordination for this cell as well as the instruments used to avoid long delays in the delivery of the product. Table 2.4 describes the number of cells that deliver to the finishing cell and mentions the priority planning procedure applied for this finishing cell. Finally, we enumerate the instruments used to manage the capacity of this cell.

Case	I Complex machines	II Complete installations	III Complex installation	IV Parts production make/engineer to order	V Parts production make to order
Delivering cells	all	two	one	all	all
Priority planning	FIFO	FIFO + informal	NA	FIFO/EDD	NA
Capacity management instruments	overcapacity overtime temporally workers	overcapacity subcontracting	overcapacity flexible operators	planning to regulate flows	overtime subcontracting temporally workers

**Table 2.4 Sequential relationship with finishing cell**

Three of the five cases allowed underutilization of the machine capacity in the finishing cell. Although the capital invested in this cell was generally high, these firms gave priority to a complexity reduction in the management of material flow and capacity. By using overcapacity, they could handle a strongly fluctuating incoming flow of material as well as relatively short throughput time requirements that ranged from 1 to 4 days. The other two cases used a different strategy. In case V, the finishing department had less overcapacity, while all parts-producing cells delivered to this cell. As an instrument for capacity management, this firm hired temporally employees for preparatory activities in the finishing department. Case IV used planning as an instrument for capacity management. The expected load of the finishing cell in the next week was presented to the parts-producing cells and the incoming flows of material were regulated based on this profile. Note that in this way not only the sequential relationships between the parts-producing cells and the finishing cells were used, but that also the relationships between the parts-producing cells were recognized in planning the system, as will be further discussed in the section on simultaneous relationships.

The *fifth sequential relationship* describes the relationship of a parts-producing cell and a cell that performs assembly operations. These operations can partly be decoupled from the operations performed within the parts-producing cells by specifying and communicating a planned start date for the assembly operations and by using a buffer policy, e.g., using safety stock or safety lead time. However, co-ordination can also be performed by a detailed planning of the flows to the assembly cell or by using the available flexibility in the planning within the assembly cell, e.g., by changing the sequence in assembling the various modules. In that case, the size of the buffer can be much smaller. In Table 2.5 we describe the type of planning of these sequential relationships with the assembly cell and the buffer policy used.

In case I, the planning of the assembly cell is used to plan the flows from the parts-producing cells in detail. Case II planned the start date for the assembly of a complete installation. This installation consisted of various modules that had to be assembled. The required parts for all modules had to be present in the warehouse three days before the planned start date of the assembly of the complete installation. So the co-ordination of the flows from the parts-producing cells was based on this overall start date and not on a detailed planning of the assembly cell that specified the planned start dates of the individual modules. This enabled case II to use the available flexibility in the planning of the assembly cells if problems with respect to the incoming flows occurred, but it resulted also in a higher total amount of stock. Case III and IV used safety stock as a buffering policy for a large percentage of the parts that were required in the assembly. Case V did not recognize that for the welding of some complex products in the pre-assembly cell the co-ordination of the required parts flows was necessary. The due date for the required product was specified in the planning, but the start date for welding the product had to be determined by the foreman of the welding cell. The stock of required parts that was kept in this cell was not controlled. This resulted in an unexpected arrival of orders for these parts with very short lead times in the parts-producing cells, which caused disturbances in their own planning and a very low lead time performance on the assembly products. This illustrates that it is important to recognize the existence of this type of sequential relationship and to select an adequate set of co-ordination instruments.

Case	I Complex machines	II Complete installations	III Complex installation	IV Parts production make/engineer to order	V Parts production make to order
Planning	flow of parts planned in detail	flexible planning within assembly cell	planned start date assembly	planned start date assembly	not planned
Buffer policy	safety lead time	safety lead time	safety stock	safety stock	no buffer

**Table 2.5 Sequential relationship with assembly cell**

To summarize, this description of five types of sequential relationships in cellular manufacturing and the discussion on the resulting co-ordination requirements and the various co-ordination mechanisms applied illustrates the complexity of problems on this co-ordination level in cellular manufacturing. Our description has mainly focussed on material and information flows between a parts producing cell and other cells, but sequential relationships because of resource flows did exist as well. A production planning system for cellular manufacturing must pay attention to these sequential relationships between cells.

However, the segmentation of the transformation system (i.e., the number of cells in sequence) need not correspond with the main co-ordination requirements of the system, as the complexity of co-ordinating these sequential relationships may differ. The relationships that we identified in the five case studies have illustrated this varying complexity. We will have to consider the effect of this complexity on the design of a planning system for cellular manufacturing. The design of such a system should resemble the characteristics of the cellular organization and should consider the resulting sequential relationships.

### § 2.3.2 Simultaneous relationship

In this section, we give some examples of simultaneous relationships between parts-producing cells that we encountered in the five cases studied.

Case I painted the products in one of the three available colors in the finishing department. Two of these colors were used regularly, but usage of the third was only irregularly specified in a process plan. The determination of a date for starting the third color did not take into account the possibility of feeding cells to deliver the required materials in time. This either resulted in a low utilization of the resources in the finishing department, because of waiting time for these parts, or in a high investment in material, because of too early delivery of parts to this department. To become more efficient, the firm had to recognize the simultaneous relationship between the cells that produce parts that would require this color. The planning of these cells could then be tuned to determine an acceptable start date for painting.

The sequential relationships between parts-producing cells and the finishing cells in case IV were co-ordinated by plan. Planning also recognized the simultaneous relationship between the parts-producing cells. These cells received information on expected peaks in the load of the finishing cells for the next week. This enabled them to regulate their flows to these cells by mutual agreement.

Case III did not recognize the simultaneous relationships in the production of module Y. The sequence of processing this module consisted of five steps, but more than five cells were involved in the production of the module, as some of them produced in parallel. If one cell could not finish its production on time, the next cells in the processing sequence were notified. However, cells in the same processing step that produced simultaneously for the

same module were not notified of the expected delay. So they still tried to produce their parts on time, possibly delaying other parts or using overtime.

Case II, IV and V encountered these simultaneous relationships between cells that produce for the same assembly. As could be seen in the former section on co-ordinating the sequential relationship between an assembly cell and a parts-producing cell, the material flows from the latter type of cell were not planned in detail. The mutual relationship between these parts-producing cells can be regarded as a simultaneous relationship. In the planning of these cells, information on the planning of the other cells could be used, but these cases did not use this information explicitly. However, they recognized that usage of this relationship could improve the overall performance of their cellular systems.

We conclude that shop performance can improve if a production planning system for cellular manufacturing takes into account the simultaneous relationships between cells in the system. The co-ordination of these simultaneous relationships is often done by mutual agreement, but a planning system can provide the related cells alternatively with the required information.

### § 2.3.3 Latent relationships

The last type of relationship that we distinguish is a latent relationship. Latent relationships between cells for which the direction of the flow not yet had been determined were found in all cases, due to the existence of pools of shared resources. We could often easily detect these pools by looking for a central storage location of the tools and fixtures. Central storage usually implied that shared usage of these resources was allowed, even if the particular resource was duplicated.

Other examples of latent relationships caused by sharing of resources were found in case II and III. In case II, the tools shared by the assembly cells sometimes constrained the planning within these cells. In case III, the transportation equipment for handling material within the cells was shared, potentially causing delays in the progression of the production. None of the five cases did register which cell had the disposal of which tools. In case V, it was estimated that 5% of the orders were delayed due to the required tools being not available at request. In case I, II, and III, tools have mainly been duplicated. Case IV and V also had duplicated tools, but this solution was considered here too expensive. They had more problems to justify this investment economically, but still preferred this solution of buying themselves out of trouble.

The next latent relationship we consider here is caused by the possibility of allocating an order to more cells. If both cells are able to perform the required operations, we can choose to what cell the work is released. In case I, II and III, this relationship existed only for a small percentage of the orders. Case I and II did not use this flexibility, case III incidentally. Case IV and V encountered this relationship for a large percentage of the orders. Case IV used this

flexibility incidentally, while case V used this flexibility intensively in their planning system by letting the cell foremen choose among the available orders.

Latent relationships due to the existence of alternatives could be seen in the reallocation of operators to another cell. The cases coped differently with the resulting co-ordination requirements. Case I and III had explicitly defined human resource pools. These pools were restricted to a cluster of cells and the people in these pools could change to another cell in case of illness of a cell member or rush work. Human resource pools are generally used for a short period and can be asked for at a short term. Another co-ordination mechanism that was used is temporally reallocation of operators, e.g., for a period of one week. Case I and II considered this when they discussed the production plan for the next week. Case IV and V used this kind of flexibility only incidentally.

Another latent relationship can be encountered due to alternatives in the process plans. Case I recognized this relationship in the loading of a temporally bottleneck in a particular parts-producing cell. If the cell workers concluded that this machine became overloaded, they could interchange work to another cell. In this cell, the NC programs were rewritten, which could be provided within 15 minutes. In case IV, interchange of work was also possible, but here rewriting the programs was done within the engineering department, causing a two-day delay and flows of information between the cells and this department. Case V was not even able to rewrite the programs within a reasonable time, so they were not able to use this latent relationship between the cells.

We conclude that latent relationships identify available flexibility in the relationships between cells. A planning system may be designed such that it enables the cells to effectively exploit this flexibility. We should therefore identify the factors in a planning system that resemble this flexibility. However, there is always a trade-off between flexibility and transparency. A system with many latent relationships between cells because of an inadequate process planning will result in many co-ordination problems for the resulting sequential relationships between cells after they have been determined. The lack of transparency and time for preparation may result in a system that is flexible without being productive.

In this section, we demonstrated the existence of three types of relationships between cells for the five cases that we studied. The differences between the cases were illustrated by elaborating on the way they coped with the co-ordination requirements that resulted from these relationships. We have identified some consequences of these relationships for the design of a planning system for multi-stage cellular manufacturing systems.

## § 2.4 Conclusion

This chapter has analysed the various relationships between cells in the primary transformation process of the production system. The situation of small batch parts producing firms that use cellular manufacturing has functioned as a frame of reference.

Many authors in the field of cellular manufacturing give the impression that the co-ordination issue within cellular manufacturing is quite easily tractable. They assume that the flow of material between cells has been minimized and the problem of scheduling the flows within the cells has been solved by decentralizing the planning tasks to the cells. In this chapter, we have shown that this is a far too simple view of the co-ordination issue within cellular manufacturing. The flow of material between cells is not the only type of flow that has to be considered, as the flow of resources and information also has to be taken in consideration. Furthermore, the flow of material between cells is often more complex than described within this literature due to factors such as subcontracting work and assembly operations. Finally, we have shown that the material flow generates different co-ordination requirements depending on the characteristics of the situation.

Decentralizing the task of detailed cell scheduling to cells is not sufficient to solve the type of co-ordination problems that cells will face in multi-stage cellular systems. Cell scheduling will frequently interfere with problems and decisions of other cells.

The relationships between cells involved in the primary process can be distinguished in three types: sequential, simultaneous and latent relationships. Sequential relationships describe the existence of flows between cells, simultaneous relationships the existence of parallel connected activities, for which the sharing of information may result in improved system performance, and latent relationships describe the existence of flexibility in the process plans or in the production plan with respect to the allocation of operations, resources, material or information to the cells. Introduction of these three types of relationships between cells results in a more comprehensive description of co-ordination requirements. This instrument provides a better understanding of the complexity of the co-ordination issue within cellular manufacturing.

We have analysed the three types of relationships that occurred between cells in five case studies. A selection of the observed relationships has been presented and we have used them to identify specific co-ordination requirements between the cells and to describe differences between the cases in coping with these requirements. We can conclude that the identification of these relationships is important for designing a planning system, as it improves the recognition of the possibilities and constraints in co-ordinating the system. The disclosure of specific relationships between cells has made it in some cases possible to identify deficiencies in the application of co-ordination mechanisms. Comparing the different co-ordination

mechanisms used by the cases for similar co-ordination requirements has allowed us to present alternative co-ordination mechanisms for these situations.

The co-ordination issue in firms that use cellular manufacturing in their production of parts is highly complex due to the various flows that have to be co-ordinated and the flexibility that has to be present in the system. The use of the framework helps to identify these co-ordination requirements.

In designing a planning system for cellular manufacturing, we should consider the various relationships between cells. The decision about creating co-ordination requirements within the system is influenced by specific design choices of the planning system. The same holds true for the decision about allocating planning and co-ordinating tasks and responsibilities in the system. Therefore, we have to examine in the next chapters the consequences of planning system design choices for the co-ordination requirements within multi-stage cellular manufacturing systems.

We will focus on one particular well-defined planning system for cellular manufacturing, the basic unicycle period batch control (PBC) system. The number of design choices in this system is limited compared to other systems that are used in practice. The PBC system focuses on co-ordination between the stages. A more profound knowledge about the effect of design choices in such a system will help us to improve the design of other planning systems for multi-stage cellular manufacturing as well.

## Chapter 3 Period Batch Control

This chapter describes the Period Batch Control (PBC) system, a production planning system that has strongly been advocated for application within cellular manufacturing. It is said to be a simple and effective instrument in obtaining the benefits of group technology.

Firstly, Section § 3.1 presents the principles of PBC. Section § 3.2 considers the suitability of PBC for planning a cellular organized production system. Section § 3.3 shows the historical development of PBC, pays attention to various configurations of PBC that appeared in literature, and discusses contributions of literature on differences between PBC and other planning principles, such as Material Requirements Planning (MRP), Optimized Production Technology (OPT), and Kanban. Finally, Section § 3.4 presents an outline of our research on PBC system design.

This chapter answers the second research question:

*What are the main factors  
that distinguish the basic unicycle Period Batch Control system  
from other planning concepts in supporting the co-ordination requirements  
in a multi-stage cellular manufacturing system?*

and it further introduces the design problem of Period Batch Control systems, which is treated in the remaining Chapters Four to Eight of this dissertation.

### § 3.1 Principles of Period Batch Control

Period Batch Control is a cyclical planning system that co-ordinates the various stages of transformation that are required in order to fulfil the demand of the customers. Effective co-ordination of the supply chain should make it possible to avoid or reduce decoupling stocks or other types of inefficiencies between successive transformation processes.

PBC differs from other planning systems in the way it accomplishes this co-ordination, and more specifically, in the three principles it applies in configuring the planning system:

- 1 **Single cycle ordering** refers to the *frequency* of releasing work orders:  
each part has the same ordering frequency as its parent product
- 2 **Single phase** refers to the *release moment* of work orders:  
work orders are released to the production system at the same moment (defined as the *start* of a period)
- 3 **Single offset time** refers to the *lead time* of work orders (per stage):  
all work orders have identical lead times

The combination of principles 2 and 3 leads to work orders in the production system having all both identical release dates and identical due dates. The time available for completion of a work order, the offset time, is equal to the period length  $P$  or a multiple of  $P$ . The length of  $P$  is therefore an important design parameter of the PBC system.

We may still face the situation that the cycle length of products vary, even if we apply both principle 2 and 3. We define the *unicycle PBC system* (a term introduced by New, 1977) as a PBC system that uses the same cycle and same phase for all products and parts. Figure 3.1a shows such a system. All products A, B, C, and D use different order sizes. If an order is produced, the inventory curve starts to increase. If no production occurs, inventory decreases. A cycle is depicted as a shaded area, i.e. it is the time between two deliveries. All products do also use the same phase, as they start producing at the same moment in time.

In a unicycle PBC system it is still possible, although not very useful, to apply a cycle length for release of work orders to the system that differs from the offset time. This may be the case if the offset time is either greater or smaller than the cycle time. Figure 3.1a illustrates the situation of an offset time of one month and a cycle time of two months. The offset time is for each product only one month, as work orders are finished and the inventory curve starts decreasing after this month. Figure 3.1b shows an alternative with cycle times equal to the offset time. We will examine the latter system in detail and define it as follows:

*The basic unicycle PBC system* is a unicycle PBC system with a cycle time equal to the offset time. A unicycle PBC system uses the same cycle and same phase for all products and parts.

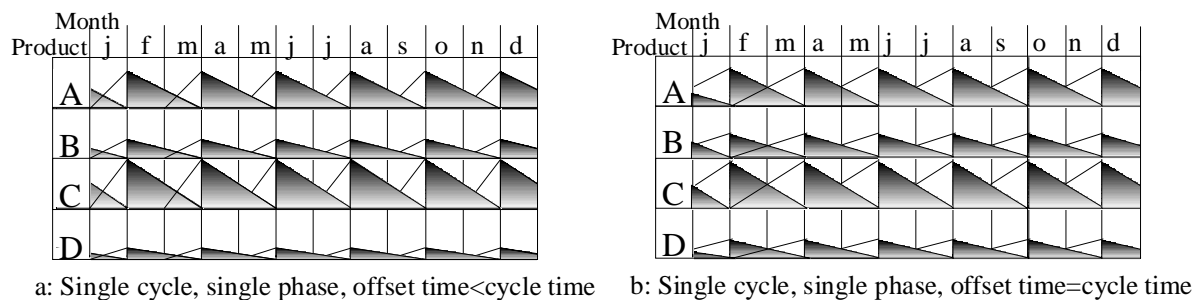
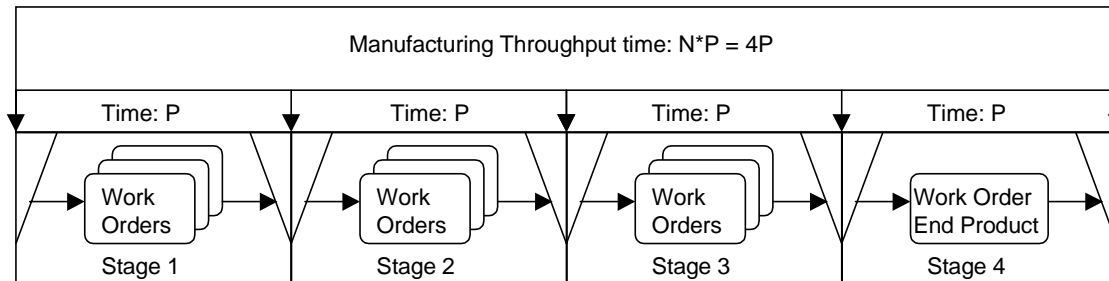

**Figure 3.1 Unicycle (a) and Basic Unicycle (b) PBC system (compare Figure 3.11)**

In order to obtain the required amount of an end product, often several transformation processes are involved in sequence. Subsets of work orders for these processes may be combined into a stage, which means that these work orders will be produced during the same period of time (*when*). A reason for such a subset may be that these orders are performed within one cell (*where*), or that input material is too costly. PBC releases work orders per stage, so a network of work orders has to be completed involving several periods of time.

We define  $N$  as the number of successive stages that are co-ordinated using PBC.

In a PBC system, the total throughput time  $T$  is determined by the product of the period length  $P$  and the number of stages  $N$  that have to be visited. If all products require processing according to this sequence of stages, they all have identical throughput time  $T=P \cdot N$ . Figure 3.2 shows the basic scheme of a PBC system with four stages.



**Figure 3.2 Basic PBC scheme**

### § 3.1.1 Basic Unicycle PBC is a Single Cycle system

PBC is a single cycle system. It uses the same planning cycle for all products that are controlled with this system and each period it releases the work orders for all required parts and components for the amount of end product required in the next cycle. This periodicity is an essential feature of the PBC planning system, as it leads to the same frequency of occurrence of products in the plan, unless these products have lumpy demand.

Burbidge (1996) distinguishes between single cycle systems *at programming level* and *at ordering level*. Single cycle systems *at programming level* use the same planning cycle for all products that are controlled with the system. Each period, orders for these products can be released. If products can be ordered each period, this reduces either the customer order lead time or the average finished product inventory. Multi cycle systems *at programming level* apply different ordering frequencies for the products that are made.

Single cycle systems *at ordering level* translate the released orders for end products to *balanced sets* of orders for parts and components, by using lot for lot explosion. Work orders for parts are in this case also once per period released to the system. The main advantage of balanced ordering is the direct relationship between production requirements and end product requirements one or more periods ahead. This reduces the amount of work in progress and manufacturing throughput time. Additionally, it results in clear objectives for the production system, as they have to make what is actually needed in the next stage. Multi cycle systems *at ordering level* might either allow multiple release moments per period (for example, several containers in a Kanban system) or apply batching with order quantities larger than the amount required during one period, for example multiples of economic order quantities.

Burbidge (1990) argues against the use of both types of multi cycle systems, as they result in variations in the loading of the system over time, the *surge effect*. We illustrate this effect for a multi cycle system at programming level in Figure 3.3.

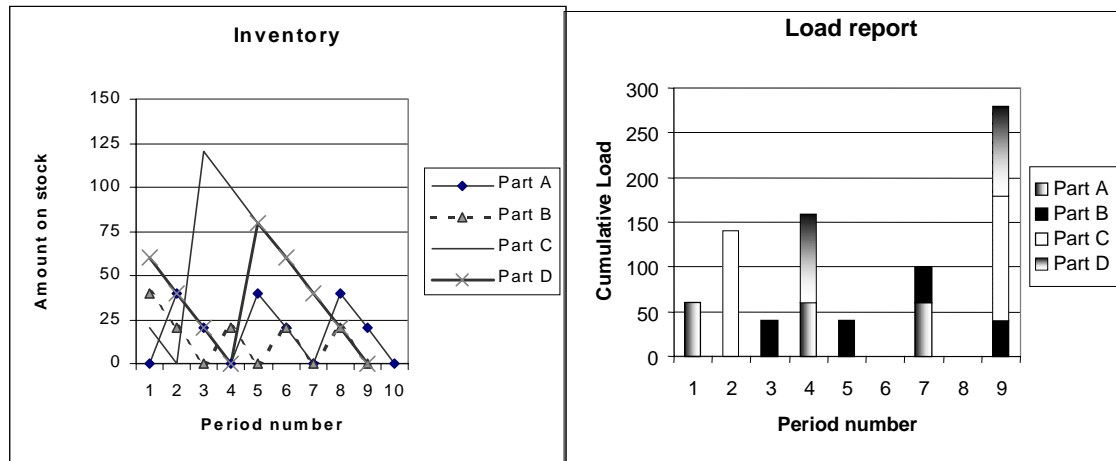

**Figure 3.3 Surge effect: load fluctuations due to unequal planning frequencies**

All four parts in this figure have different planning frequencies but an equal demand rate. The amount of inventory of these parts over time is presented in the left hand side of the figure, assuming a constant continuous demand. Production of a new batch of a part takes place during an offset time of one period. The resulting load on the system is shown in the right hand side figure. It shows that in some periods multiple batches are produced, while in other periods (6, 8) no batches at all have to be produced. This fluctuation is called the surge effect.

The arguments of Burbidge (e.g., 1990, 1993) against multi cycle systems are not valid for all types of multi cycle systems. In Chapter Five, we will discuss the use of (powered) nested order frequencies, both for parts and for products. With such order frequencies, the phasing of the various parts can be arranged such that the resulting load fluctuations do not exaggerate the fluctuations that are caused by demand variations.

Burbidge incorrectly assumes that all types of multi cycle systems apply both independent stock control and independent lot-size determination<sup>1</sup>. However, multi cycle systems are not equivalent with independent decisions in the supply chain, but with different decisions with respect to parts or products.

Unicycle Period Batch Control is single cycle both at programming and at ordering level.

<sup>1</sup> As the terminology of Burbidge with respect to multi cycle and multi phase is not consistent, his arguments against multi cycle systems are sometimes confusing. In some cases, these arguments may remain valid if we read multi offset time or multi phase systems. See e.g., Burbidge (1989a), where he argues that multi cycle systems generate balance of load records (capacity profiles) that do not show if there is sufficient capacity. This conclusion holds for multi offset time, but not for multi cycle systems.

### § 3.1.2 Basic Unicycle PBC is a Single Phase system

PBC releases work orders in a single phase. At the release moment, all work orders have to be made available to the next stage. Multi phase systems allow different moments for release of subsets of work orders. A single phase system introduces a synchronization moment for the system, which is comparable to the transfer moment in an *intermittent serial line system* (see Scholl (1995)). We will elaborate on this analogy with serial line systems. Intermittent serial line systems with one or more workers per station are applied for many reasons of efficiency:

The first reason is that they provide clear but realistic objectives. All workers in such systems know at what time the system will require that their work has finished. If some stations are not able to complete their work package within this time, other workers that have finished their work might offer some help or else make it easier for these stations to accomplish their task within the available time<sup>2</sup>.

The second efficiency related reason for applying serial line systems is that workers do not have to worry about the availability of required materials and tools. The transportation system organizes the transfer of work between stations, so there is no need to build up an input buffer before the work station. Availability of materials, components, and tools are guaranteed by other parts of the production system, which are responsible and specialized in these supply activities. Often, a logical decoupling from supply and usage of these materials is found, which reduces search time and accommodates an appropriate division in responsibilities. Otherwise, search time would become a significant part of the total station throughput time.

The synchronization in PBC due to the single phase principle is directed towards obtaining both types of benefits. Hence, the design of a PBC system should accommodate the determination of realistic objectives and a corresponding decomposition of the system.

The single phase principle of PBC causes a *less nervous* situation at the floor, as the set of work orders for this part of the production system is released at once. *Stability* during a period is achieved. This also means that in principal there will be *no disturbances* due to unexpected arrival of customer orders during the period. Pure single phase systems do not allow rush orders that arrive during the period. The inflexibility can partly be nullified by using small spare parts inventories. Rush orders for spare parts are then supplied from stock and the demand is replenished during the next period.

---

<sup>2</sup> The system of synchronous transfer in serial systems works in general only if it is possible to finish the work before the transfer moment, so the objectives have to be realistic. It prohibits that workers increase their independence from other contributors in the system. Such independence might work counterproductive, as it leads to more buffer inventory or decoupling inventory in the system in order to avoid blocking or starving, less awareness of problems in other parts of the system, and less incentives for improving the whole system instead of searching for local improvements.

If we compare single phase systems with multi phase systems, we see that the latter result in less overview of the complete amount of work that has to be performed within a period. This reduces the possibility to find a best way of working. If part of the work package arrives early in the period, and another part half way the period, then the planning of a resource that is required by both work packages is more difficult, as relevant information still has to arrive, while other related decisions (such as set-ups) already are being executed.

However, from this comparison we cannot draw the conclusion that single phase systems should be preferred to multi phase systems. Recent developments in the field of continuous work order release systems (see e.g., Land and Gaalman, 1998, van de Wakker, 1993) show that information on the actual progress of work at the shop floor can effectively be used for improving the release decision. Therefore, the advantages of single phase systems need not be prevailing in each production situation.

### § 3.1.3 Basic Unicycle PBC is a Single Offset time system

PBC is called a single offset time system, a term introduced by Steele (1998). PBC uses the same internal throughput time (offset time) for work orders that are released to a stage. This results in the same manufacturing throughput time  $T$  for all products that require an identical number of stages. As a consequence, the definition of these work orders becomes very important. Traditionally, these definitions can be deduced from the levels in the Bill Of Materials (BOM)<sup>3</sup>, but the throughput time that is needed for such a level transition is determined separately. Both decisions (work order definition and work order throughput time determination) are managerial decisions with a strong impact on production planning.

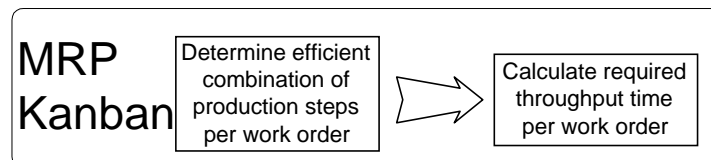

### Decomposition of product structure in work orders

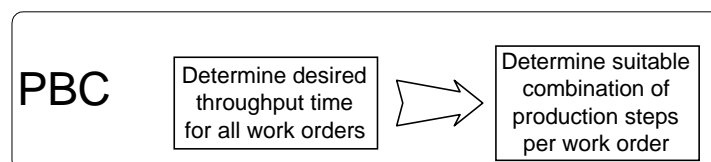
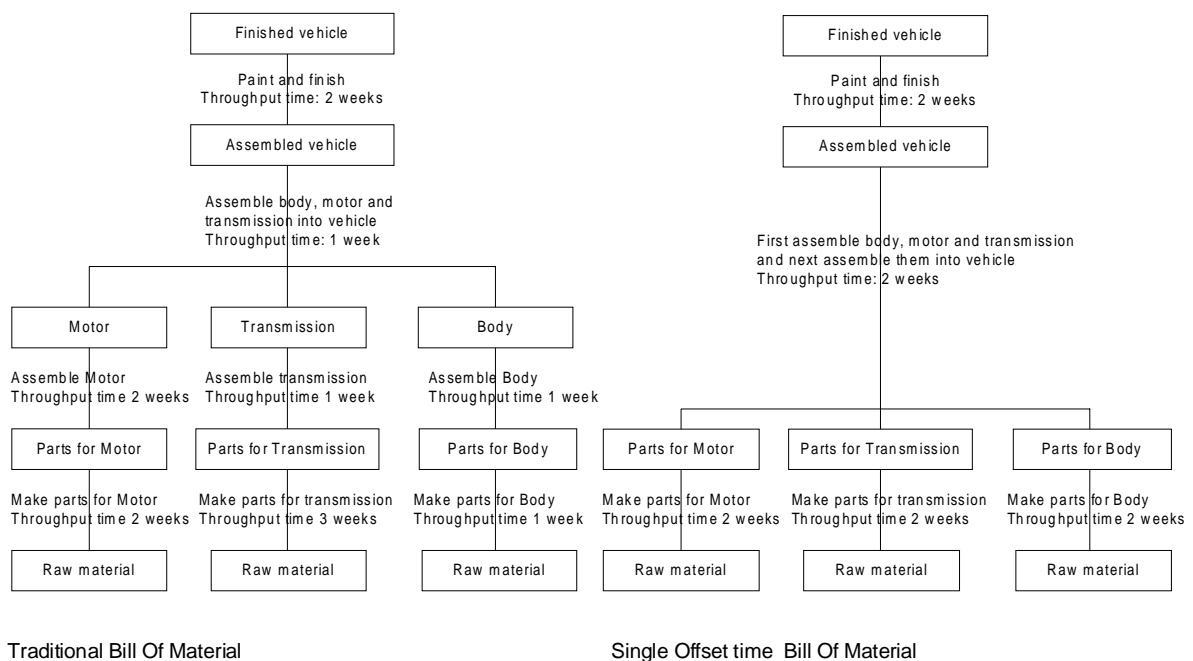

**Figure 3.4 Work order definition in MRP and PBC**

<sup>3</sup> Bill Of Materials A listing of all the subassemblies, parts, and raw materials that go into a parent assembly showing the quantity of each required to make an assembly, Apics (1980)

Within MRP and Kanban systems, the number of operations that are combined into one work order (production Kanban) depends mainly on the organization of the production facilities and the possibility of obtaining efficiencies from batching. If an efficient combination has been determined, the planned throughput time or Kanban lead time for this set of operations is being fixed. This makes the managerial decision about the length of the planned throughput time a consequence of the implicit managerial decision about the desired combination of operations in one work order. In general this leads to multi offset time systems, as the required throughput time per work order may differ for the various combinations of operations that are distinguished.

PBC systems start at the opposite side, as shown in Figure 3.4. The managerial decision about the desired length of the planned throughput time per work order precedes the managerial decision about the combination of operations into a work order. The throughput time decision has to be equal for all work orders in a single offset time system. That decision can therefore constrain the definition of work orders, as each work order within a stage has to be finished at the end of the offset time. So it affects the speed, dependability, and flexibility of the system.



**Figure 3.5 Example of traditional versus single offset time Bill of Material**

We constructed an example in Figure 3.5 that shows the different BOM structure due to the single offset time principle. The left hand figure shows a traditional BOM structure with varying throughput time per work order (level transition), but relatively simple content of work orders. Within the production organization, it will be easy to address these work orders to specific parts of the system. For example, the work order for motor assembly can be found within the department that assembles motors. Planned throughput time is rounded up to an integral number of weeks. Expected throughput time will be less than this number of weeks.

The example of the single offset time BOM at the right side in Figure 3.5 shows an offset time of two weeks. Operations that can be combined into one work order and can be expected to finish within this offset time are combined into one work order. We see that this has led to the elimination of one level in the BOM. The assembly of Motor, Transmission and Body into an assembled product took less than one week, and could be combined with the assembly of the individual components without exceeding the throughput time of two weeks. The same holds for the production of parts for transmission, which now takes only two weeks. This may require a different priority system with respect to the allocation of resources to the work orders, as the critical capacity for producing parts for the transmission is also used by the less critical production of parts for the body. This set of measures reduces the total cumulative throughput time with one week.

The single offset time principle leads to a re-consideration of BOM structuring in planning system design. Browne et al. [1988: 264] note that '*the BOM concept may have had too much influence on the design of shop floor routings*'. PBC provides an alternative.

#### § 3.1.4 Variants of PBC in practice

The basic unicycle period batch control system is single phase, single offset time, and single cycle, both at programming and at ordering level. Many of the systems that are known to operate as a PBC system are variants of this specific system. This holds true both for systems that are actually operating in practice and for systems that are described in literature. The systems that operate in practice are not so rigid as may be expected from the system description. This also makes it quite difficult to compare the effectiveness of differences in system design.

In the Netherlands, we are aware of a number of firms that have considered and applied PBC systems. Studies on the design of the planning system have been performed at Marko B.V., Veendam, manufacturer of school furniture, at the clean room assembly department of a Philips machining plant in Acht, at the parts manufacturing division of Delft Instruments, and at El-O-Matic component fabrication plant. In Chapter Four of his dissertation, Slomp (1993) describes some aspects of a PBC system in combination with a flexible manufacturing system at El-O-Matic. He proposed to use a multi offset time system. The studies showed that the specific circumstances and possibilities in managing disturbances influenced the design of the planning system and made it less rigid than could be expected from the initial system design.

Burbidge (1996) describes a number of cases where PBC systems have been implemented. He distinguishes between implosive, process, explosive, and jobbing industry applications.

In implosive industries, many product and packaging variants have to be delivered, making it uneconomical to produce on stock. The use of PBC facilitated both short delivery times and economic sequencing within a period in order to reduce the total set-up time needed. Variants

can be found with respect to the single cycle at programming level principle. The single phase principle allowed the development of specific sequences, as all orders that had to be produced within the period were known in advance.

Applications of PBC in food processing industry showed the same pattern, but here the PBC systems operated with one day periods, and shorter period lengths of half a day or one shift were also possible, if required by the short shelf life of the products. The short periods were still preferred over continuous production, because of the possibilities to change the sequence of processing work orders between stages, enabling the system to find sequences that efficiently used the various facilities, such as ovens, freezers, and other equipment that led to sequence dependent set-up times.

Most PBC systems that are described regard explosive industries with both assembly and component production. The PBC systems for these situations had to face long throughput times. The PBC systems that were developed for these cases are all specific variants of the basic unicycle PBC, as company specific solutions were developed that made it possible to shorten the total throughput time and improve the co-ordination of subsequent stages. The systems were mainly single cycle at ordering level, but variants with respect to the single phase, single offset time, and single cycle at programming level principles were developed.

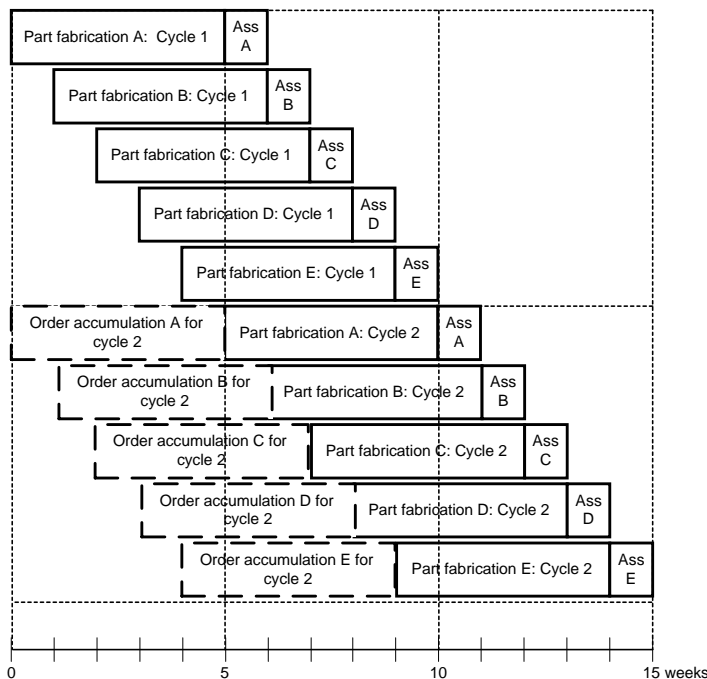

**Figure 3.6 Kumera Oy Cyclical planning system**

Other PBC systems found in literature are from Whybark, 1984, Borgen, 1996, and Melby, 1994. Whybark (1984) describes a single cycle, multi phase, multi offset time system. He reported on a cyclical planning system for the Finnish Kumera Oy. Details on his system are described in Figure 3.6. The cycle time of the system is five weeks. The offset time in parts

production is equal to this cycle time (five weeks), but in assembly, work orders have an offset time of one week. The system is not single phase, as work orders for different part types are released in separate weeks. The total throughput time of an order consists of six weeks manufacturing lead time and maximum five weeks pre-release waiting time. Whybark found an increase in inventory turnover from 2.5 to more than 10 times a year, and a delivery accuracy increase from 50% to 98% of orders less than 3 weeks late.

Borgen (1996) applies a PBC system for co-ordinating the production of newspapers. He focuses on the pre-press production stages and designs a single cycle, single phase, single offset time system with flexible allocation of capacity to the various stages. Main advantage of this PBC system is a synchronized transfer and fewer interrupts during a period.

Melby (1994) describes a period batch control system at Norsk Kongsberg Defense and Aerospace Maskinering/Montasje. The machining department and assembly operated with a four week cycle with weekly loading and a PBC system was developed for the planning within the production cells.

From this review, we conclude that the principles of PBC are not blindly applied when designing a PBC system for a practical situation. A trade-off should be made between the advantages of applying the principles and the costs of their application in these situations. Note however, that the design of a PBC system is not a one time exercise, as improving both the production and planning system are essential. The basic unicycle PBC system may therefore function as an ultimate goal for many of the PBC systems found in practice, comparable with the zero-inventories crusade that was propagated in Japan and in APICS literature of the 1980s.

### § 3.1.5 Operation of a PBC system

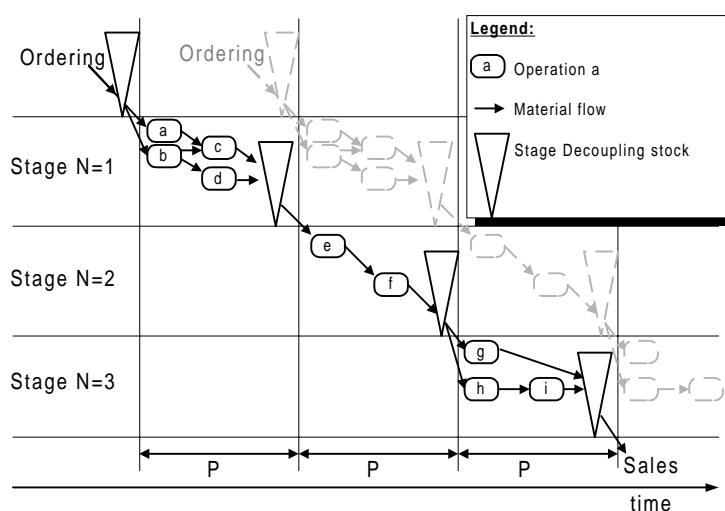

**Figure 3.7 PBC system with 3 stages**

The operation of a basic unicycle PBC system can be illustrated with Figure 3.7. Before production starts, the required raw materials have been ordered and received such that at the start of a new period they are made available to stage  $N=1$ . The operations in this stage are performed according to the specified work orders and have to be ready before the end of the period with length  $P$ . Parts and components can be put in a decoupling stock where they await transfer to the next stage. All work orders have to be finished before the start of the next period in order to effectively decouple both stages. At the start of the next period, the work orders for the next stage are given to the machine operators, who may start them at a free resource, and the required materials can be transferred as they are available in the exact amount needed in the decoupling stock position. At the same time, the operations in stage  $N=1$  receive new work orders that again have to be completed within one period length  $P$ . As each stage in the production system has exactly one period of length  $P$  available to complete the required operations, the total manufacturing throughput time  $T$  equals the number of stages  $N$  times this period length  $P$ .

The length of the customer order lead time depends on the positioning of the Customer Order Decoupling Point, CODP, a term introduced by Hoekstra and Romme (1985). Assume for simplicity, that we do not hold anonymous inventories, i.e. we purchase to order. Then the customer order lead time will also consist of time for ordering raw materials, required parts, controlling designs and required tools, and so on. PBC allocates these activities in a preceding ordering period  $O$ . The products for which these activities are performed have entered the system during the order acceptance period  $AC$ . The delivery of the products to the customer is assumed to take place in a separate stage after production is finished: sales period  $S$ .

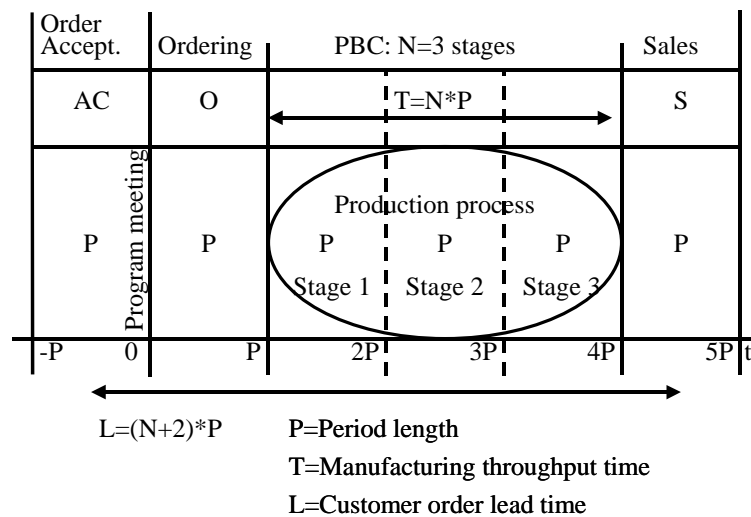

**Figure 3.8 Customer order lead time  $L$  versus Throughput time  $T$**

The necessity of the stages  $O$  and  $S$  depends on the characteristics of the supply chain, i.e. the length of the delivery times of both the required parts and the end product. Most publications on PBC in complex manufacturing situations assume that separate ordering and sales phases are required, but in practice solutions may be found that can eliminate the necessity of these stages. Burbidge (1975a, 1993) describes several of these solutions.

The length of stages O and S need not be equal to the period length  $P^4$ , but again for simplicity, we will assume that the total customer order lead time also includes an ordering and a sales stage, both with length P. We will therefore assume that the customer order throughput time in the sales stage is between 0 and P, so the mean throughput time in stage S will be  $\frac{1}{2}P$ . The minimal total customer order lead time is in that case equal to  $(N+1\frac{1}{2})\cdot P$ . However, if an order arrives at the system just after the work package has been released to the system, a waiting time occurs before the next decision moment on order acceptance. In a single cycle system at programming level like PBC, only once per period is such a decision about order acceptance and release taken. All orders that arrive in between have to await this decision before further action is undertaken. This waiting time will not exceed P, so the mean customer order lead time is  $\frac{1}{2}P + (N+1\frac{1}{2})\cdot P$ , as illustrated in Figure 3.8. The smallest possible customer order throughput time is  $(N+1)\cdot P$ , and the largest is  $(1+N+2)\cdot P$ .

If the customer order decoupling point is located later in the production or supply chain, the customer order throughput time decreases, but the total throughput time for the product might increase, because of a longer mean waiting time in the decoupling point. The specificity of the semi-finished products in the decoupling point increases, which results in less demand per stock item and, on average, longer waiting times before demand occurs. PBC can still be used for regulating the stages before and after the decoupling point, but the anonymous production to stock before the decoupling point may also be regulated by other ordering systems.

### § 3.1.6 Planning functions in program meetings

Figure 3.8 shows a program meeting at the end of the order acceptance stage. This program meeting decides which orders that have entered the system should be accepted. It determines if specific actions have to be taken (such as hiring extra capacity) in order to complete these orders within the total throughput time. Such actions can also be considered for orders that were already released in an earlier period; for example, because capacity in a later stage, e.g. the assembly department, is less than expected when the orders were released, due to illness of some employees in the assembly department.

One result of a program meeting is a list of accepted orders that have to be released after an ordering stage O to the production system. They will be available to the customer after a manufacturing throughput time T plus the required amount of delivery time during the sales period. Other results of the program meeting include plans for the required changes in capacity in future periods, replenishment orders for spare parts, and so on.

---

<sup>4</sup> The length of AC is equal to P, but the length of O and S need not be fixed at P. The latter is not seen by Burbidge (1996). He states that in many cases the length O (the call off period) determines the period length P. If the ordering period would take only  $\frac{1}{2}P$ , the release of work orders could take place half way a period, only once per period, in order to reduce the total customer order lead time.

In terms of MRP, the program meeting can be seen as the determination of the MPS master production schedule, based on a rough cut capacity check. Burbidge introduced the term *flexible programming* for the process of determining these short term production plans that are input for the ordering process of PBC. The planning horizon that is taken into account in this program is at least the length of the customer order lead time, but it may be necessary to take a longer horizon into account.

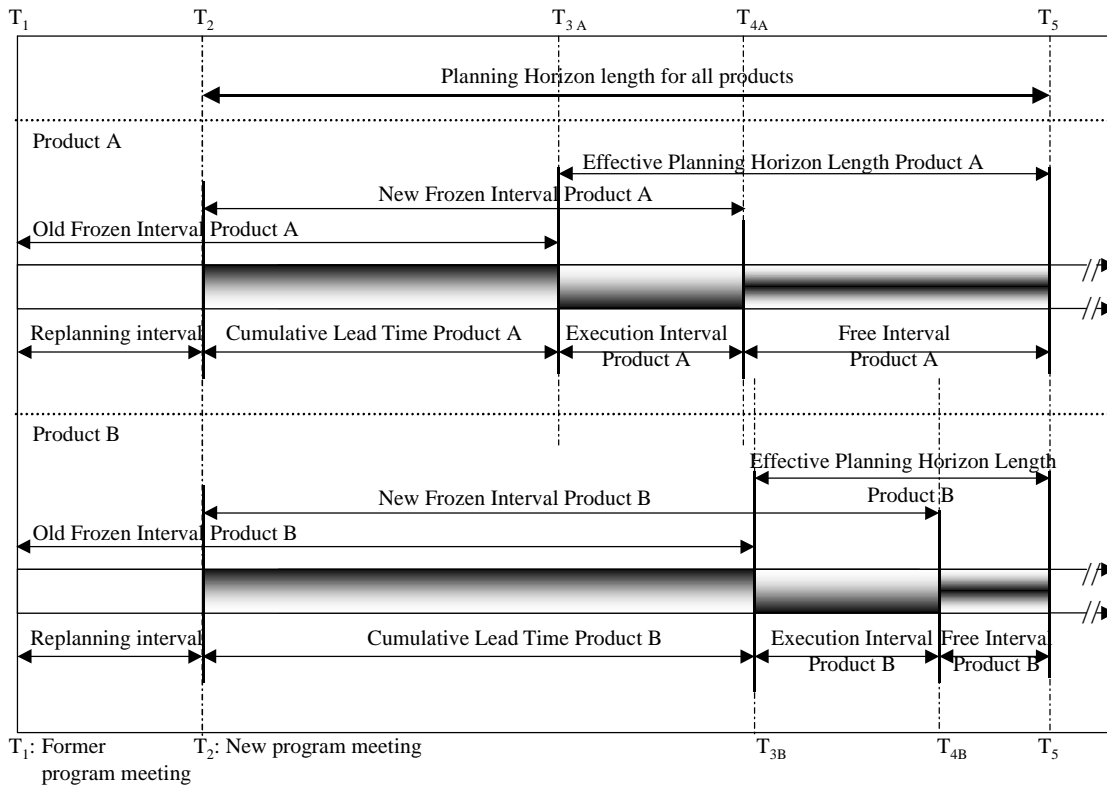

Master Production Schedule Effective Planning Horizon and Frozen Period with MRP

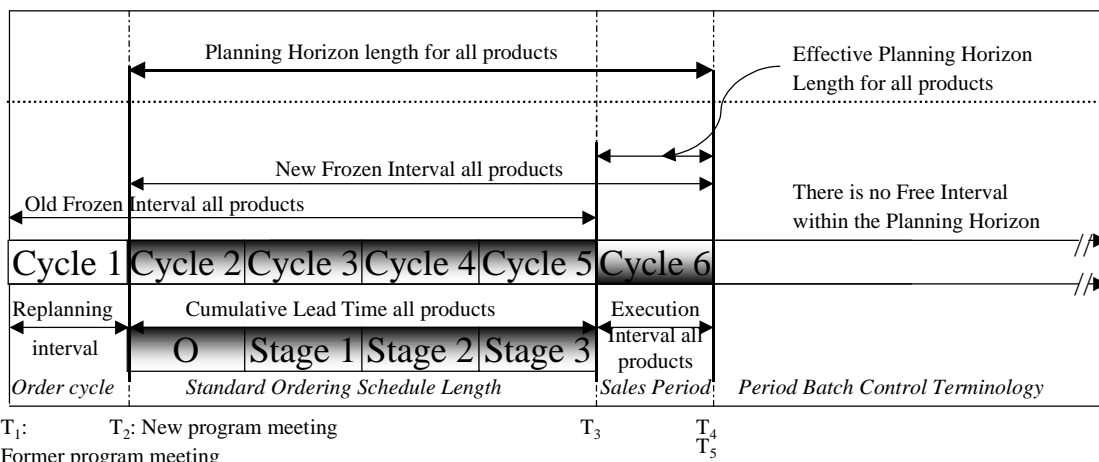

Effective Planning Horizon and Frozen Period with PBC (Purchase to order situation)

Figure 3.9 Master Production Scheduling versus PBC Flexible Programming

The difference between the PBC flexible programming approach and the MPS scheduling procedure is illustrated in Figure 3.9. The upper part of this figure shows the MPS for two products A and B, each having its own lead time. The lead time difference results in different execution periods: the future periods for which the master production scheduler has to determine the production program of these products. Even the length of these periods need not be the same in a standard MPS plan. This introduces conceptual difficulties for all people involved in the program determination.

The different timings of these execution periods also imply that the effective length of the planning horizon for these products differs. Requirement schedules of parts that are used in these final products also use this effective planning horizon. Discrete lot-sizing procedures, such as least unit cost, are sensitive for changes in the planning horizon length and may require longer planning horizons in order to become useful.

The lower part in Figure 3.9 shows the programming method of PBC. The usage of single cycle at ordering level leads to lot for lot scheduling. This implies that there is no need for a planning horizon that exceeds the execution interval. The length of the replanning period equals the execution interval. Each product has the same ordering schedule and period length. There is only one execution interval for which the final schedule is determined in the program meeting. The conceptual difficulties of scheduling for different periods in time are eliminated.

PBC terminology is somewhat different than used in other literature on planning systems (see e.g., Kanet, 1986, Sridharan & Berry, 1990, Yeung, Wong, & Ma, 1998). Figure 3.9 enables an easy comparability of the terminology used in these systems.

A program can be considered as the result of negotiations between sales, production, and other disciplines. The occurrence of strong fluctuations in the loading of the system may make it necessary to smooth production, to reallocate labour capacity, or to replenish spare parts inventory. Seasonal fluctuations may necessitate production of some products to stock. If sales requires a wide range of products with many design variants, different lead times, or different order promise times, the production program may not simply be made equal to the accumulation of sales orders that were received in the preceding period. In these cases, the standard MPS procedures apply, including the disadvantages that are inherent to them and that were discussed in Figure 3.9. The function of the program meeting within PBC changes accordingly from simply accumulating received orders and releasing work orders, as shown in Figure 3.10, to complex planning. This planning process trades off due date reliability in the short and long term and '*producability*'<sup>5</sup> of the work package. To achieve producability, other objectives than short term due date reliability play a prevailing role in the planning process, resulting in PBC systems that no more operate as single cycle systems at programming level.

---

<sup>5</sup> Producability denotes the possibility of realizing the various demands that are placed on the production system.

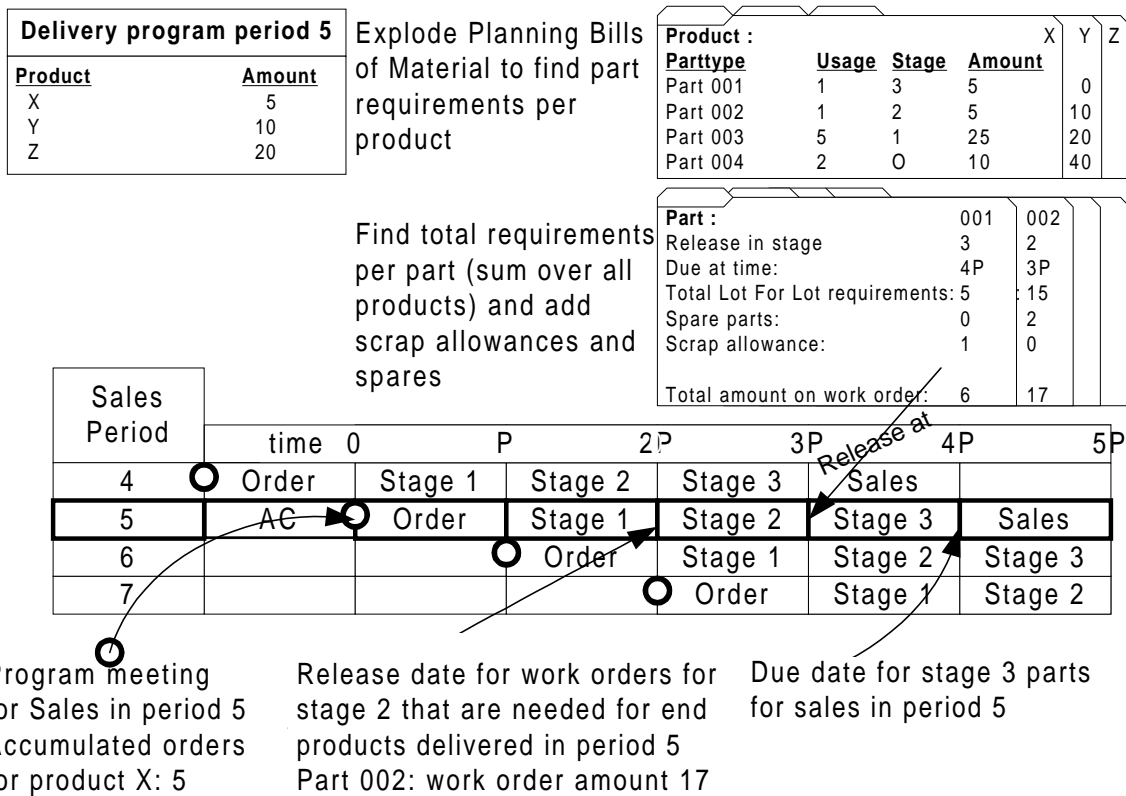

Figure 3.10 Operation of a PBC system (free to Burbidge [1975a: figure 4.2])

### § 3.2 Suitability of PBC for cellular manufacturing

Why should a system that uses the three principles *single cycle, single phase, and single offset time*, be suitable for cellular manufacturing? In general, we cannot say that PBC systems are suitable for all cellular manufacturing situations. Absolute claims on the applicability or suitability of production planning methods for a broad range of production situations will never be valid. However, some facets of cellular manufacturing may fit well with the three principles of a PBC system. We can find such facets in the typical co-ordination requirements of cellular manufacturing systems that have been determined in Chapter Two. Other facets can be found in three categories of typically desired benefits of cellular manufacturing systems: empowerment, learning capability, and delivery response (Olorunniwo & Udo, 1999). We will discuss the fit between the three principles and these facets.

#### *Sequential co-ordination requirements*

The three principles result in a time phased planning of the goods flow between successive transformation stages. Therefore, sequential co-ordination requirements between these stages are handled by the planning system. If the cellular manufacturing system requires adequate sequential co-ordination, either within or between cells, a PBC system can provide this through its stage decomposition, although it does so quite rigidly. Cellular systems that produce a complete product within one cell and do not require a formal co-ordination of the successive transformation steps may obtain better support from another planning system. It should be noted that the definition of stages is an important factor in the effectiveness of the sequential co-ordination that PBC provides. For example, stage definition allows enough flexibility to control the increase of working capital caused by expensive parts. Completing these products can be organised such that these parts are included as late as possible. Work orders for other products can be defined such that cells will be able to finish their total work package within a period.

#### *Simultaneous co-ordination requirements*

Simultaneous relationships exist if various elements in a system produce for the same end item demand. This demand is in PBC systems directly exploded (with minor corrections) into balanced sets of parts, without considering further batching possibilities. PBC does not consider other batching policies than lot for lot ordering. The time phased co-ordination mechanism allocates these work orders for parts to the various stages. This causes a direct relationship between actual production quantities for parts in a period and MPS demand in a specific future period, which enables the use of simultaneous relationships within the cellular manufacturing system. For example, the simultaneous co-ordination requirements that result if end product orders are cancelled while the production of parts already has started, are easier handled in case of such a direct relationship. The pegging procedure is less error sensitive.

*Latent co-ordination requirements*

The existence of shared resources and alternative routings in a cellular manufacturing system generates latent co-ordination requirements. The suitability of a PBC system for these co-ordination requirements depends on the specific situation.

- If operations on a shared resource are allocated to a separate stage for a number of products, the co-ordination of this shared resource can be performed through PBC. However, if a shared resource functions as a service centre with very short processing times (as described in Case V in Chapter Two), the above mentioned usage of PBC for the formal co-ordination of such a resource will probably not be appropriate, although this depends on the length of the period.
- Alternative routings can be used in PBC as far as these routings concern processes in one of the successive transformation stages. The work orders for these transformation stages will not be released to the system before the start of the next period or even later. This leaves the production planner enough time to prepare the routing change and deliver the required materials to another part of the system. Hence, information on the possibility of alternative routings may be used in determining the planning bill of materials for PBC.

The principles of single phase and single offset time enable the planning system to activate the possibilities of the system at the overall goods flow control planning without disturbing the actual progress at the floor. Multi offset time systems would make it necessary for the planning system to interfere with the detailed planning of the cell. Multi phase systems would make detailed planning within the cell less easy to accomplish. Therefore, the ability of the overall planning system to anticipate or react on changes with respect to the overall goods flow control diminishes, unless the detailed planning tasks become part of that system.

*Empowerment*

Cellular manufacturing systems expect many benefits from the changed position of the worker in the system. Empowering workers makes them more responsible for their actions and decisions. They have to receive the authority and autonomy to take these decisions, and receive the opportunity to obtain feedback on the results of their actions and decisions. The PBC system facilitates this mainly through the periodicity with which the system operates. This periodicity and synchronization of the goods flow within the transformation system leads to clear objectives, both for the system as a whole and for the various workers involved in the successive transformation stages. They know that all work that is received at the start of a period has to be finished at the end of the same period. In the mean time, no new orders will be released to their part of the system. PBC does not prescribe to them in what sequence the work orders have to be produced, if this is the responsibility of the cell workers. However, PBC restricts the authority of the cell workers through its stage decomposition. If successive operations also have to be performed within a cell but are allocated to a successive stage, cells are not allowed to proceed with these operations. The decision boundaries are clear and are not too frequently modified. Therefore, the PBC system enables a decomposition of the co-ordination that allows for the desired cell autonomy and supports empowerment.

*Learning capability*

Cellular manufacturing systems expect further benefits through the development of improved methods that focus on a rationalization and redesign of elements in the production system, see e.g. Gallagher and Knight (1986). Senge (1990) notes the development of such methods as a process of learning, which may be facilitated through stimuli from the environment. The three principles of PBC systems, stability, overview, and repetition, provide such stimuli, as they enable the work force to develop such improvements and find schedules that fit the various requirements of both their part of the system and the overall planning system. If almost the same mix of orders is repeated during successive periods, they may use this repeating pattern to develop specific solutions that make it possible to operate with a higher efficiency. For example, the quality of the schedules and the set-up and material handling efficiency may increase if specific attention is paid to the repeating pattern. The same holds true for the development of methods to reduce the amount of scrap and increase the yield accuracy of machines. These benefits of cellular manufacturing with respect to learning capability are mainly supported through the single phasing and repetition of the PBC system.

*Delivery response*

Cellular manufacturing systems often expect benefits with respect to smaller throughput times, higher dependability, lower work in progress, increased inventory turnover rates, smaller material handling costs, and so on. Olorunniwo and Udo (1999) even showed that these benefits contribute more to the success of cellular manufacturing systems than changes in the field of reward structures and change project management. The delivery response benefits that we mentioned are strongly interrelated, and they can only be achieved through modifications in the production planning system. Work should be released with shorter planned throughput times, changes should be made in the order release frequency, in the quality of scheduling within cells, and in the co-ordination of the transfer of material between successive stages. The three principles of PBC are directly oriented towards such changes. However, it depends on the specific design of the PBC system if these benefits of a cellular manufacturing system can be obtained fully by using a PBC planning system. This leads us to the argument that the PBC system supports the transparency needed to effectively exploit the advantages of a cellular organized manufacturing system. However, we consider PBC not to be a prerequisite for successful application of cellular manufacturing. Obtaining the desired benefits from cellular manufacturing will depend on the specific design of the PBC system.

**§ 3.3 PBC planning system evolution**

The three principles that are used in PBC systems seem useful in cellular manufacturing systems, as we have seen in the former section. However, the principles do not provide support for actual PBC system design choices in respect of the length of the cycle (offset)

time, and the number of stages. The evolution of the PBC system as reported in literature will provide us with insight in the historical development of thoughts on these important system design choices. This will help us to improve our understanding of this planning concept.

The changes into the field of production planning and production organization in the last decades have already been described in Chapter One. These changes have had their impact on the design of cyclical planning systems such as PBC. Literature on cyclical planning systems and, more specifically, on period batch control, gives us an impression of how these changes have been taken into account over time. In this section, we will trace these changes in literature with respect to the design of such a planning system.

### § 3.3.1 Single cycle ordering versus economic ordering

In 1960, Burbidge's first book on standard batch control appeared. This book describes his main objections to the use of economic batch quantities for the ordering of parts, which he considered to be pseudo-scientific nonsense in his first publication '*A new approach to production control*' (Burbidge, 1958). Economic ordering expects cost advantages from a trade-off between inventory holding costs and costs involved through reordering materials and fixing the order quantity at such an optimal predetermined level. Burbidge argues that the real cost advantages had to be sought in improving the material flow system and using balanced ordering of parts, based on explosion of end product demand. The economic ordering quantities do not take into account the variability of these cost factors, nor the costs of a lack of co-ordination in the system. These extra costs only become visible if product designs are changed, and the cost of irregular loading of the production system is considered. Measuring these costs is therefore not easy, and allocating these costs to planning decisions with respect to batch sizes seems less useful at the time of deciding about these batch sizes.

As an alternative to such an ordering system, Burbidge (1960) proposed always using the same small standard-sized batches for end products and ordering the required amount of parts and components. This standard batch control system only applies the principle of *single cycle ordering*, as the ordering of a small batch of end products is synchronized with the ordering of parts and components. The standard batch sizes are balanced according to the required amounts of a part in one end product. The standard batch control system is according to our definition *not single phase*<sup>6</sup>, as the moment of release of these orders depends on the consumption rate of the inventory of end products. As the rate of demand may vary, this

---

<sup>6</sup> Note that Burbidge (1962) considers the standard batch control system to be single phase. He uses another definition than ours: '*Single phase ordering is a type of ordering in which all the parts made for a given product or assembly are ordered in balanced product sets, with the same ordering cycle (start and finish times), for all of them*' [1962: 456]. Later publications introduced terms which were not consistent with this one. The definition of Burbidge contains elements of our definition of a single cycle system at ordering level (*balanced product sets*), and of single offset time (*same cycle: start and finish times*).

causes a multi phase system. The standard batch control system is *neither necessarily single offset time*, as the (planned) throughput time of a work order for a standard batch varies per part and is not predetermined at all.

For the first time in 1962, a period batch control system was described in Burbidge's book '*The principles of production control*'. Burbidge (1996) mentions that he obtained a letter from R.J. Gigli, who directed his attention to the possibility of standardizing the length of the order interval for all orders. He had described such a period batch control system in the *Material control reference book*, Associated Industrial Consultants, July 1947. The principles of period batch control originated from his work as a consultant, when he was director of Associated Industrial Consultants Ltd. in 1926. Gigli has also been working at the British ministry of aircraft production, where he was responsible for the design and application of a period batch control system for regulating the Spitfire production during World War II. Some of his applications were based on short term programs with period lengths of one week, others on four week periods. We have not been able to study the referenced work of Gigli. From Burbidge (1996) we understand that the principal ideas of Gigli's system at that time were:

- to order periodically
- balanced sets of parts for aeroplanes, in order to obtain
- high stock turnover rates

Gigli introduced the name Period Batch Control. Burbidge further elaborated this planning concept and propagated its use in combination with Group Technology.

### § 3.3.2 Single cycle, single phase, single offset time planning

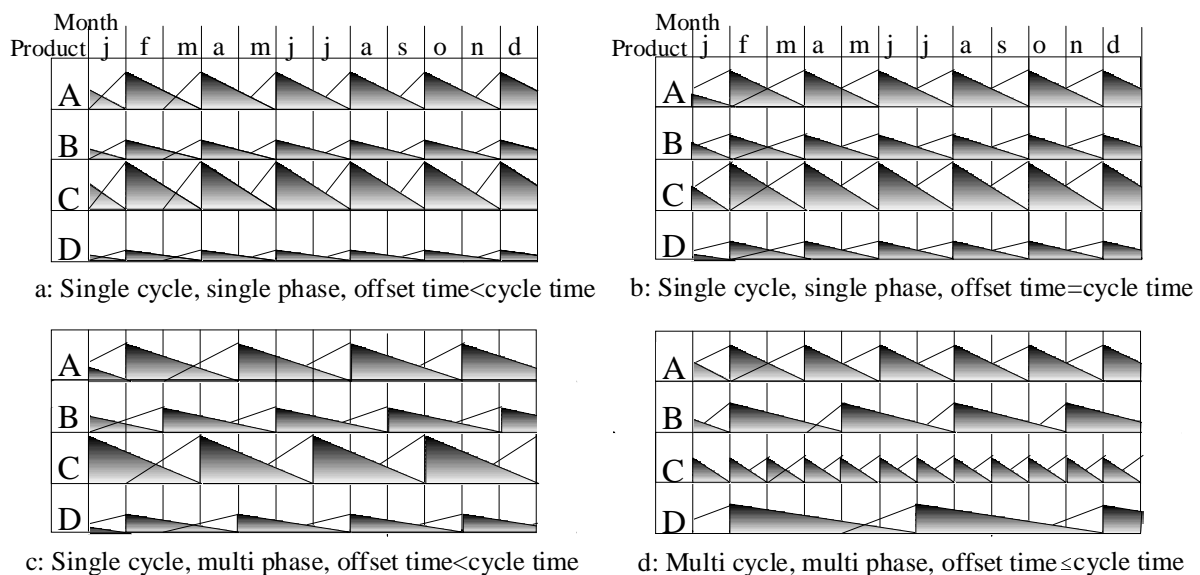
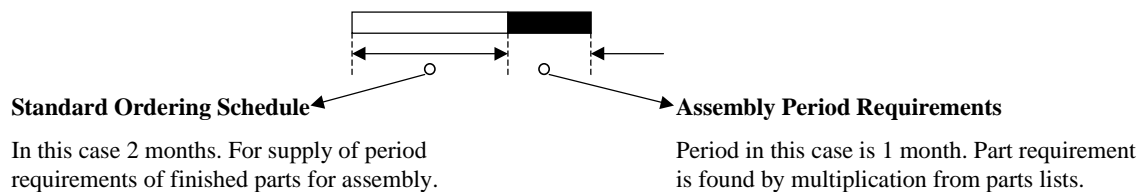

Figure 3.11 Cycle, Phase, and Offset time (a,c,d according to Burbidge [1962, fig 33])

There are some remarkable aspects of the description of period batch control that he gave in the 1962 book. The introduction of the concepts of single cycle and single phase in Burbidge [1962, figure 33] is shown in Figure 3.11. Figure a shows his interpretation of a single cycle/single phase system with a production period (offset time) of one month and a consumption period (cycle time) of two months. The quantity that is produced of each part differs, but all parts are produced during the same month. The difference with the single cycle / multi phase system in Figure c is the varying start and finish moment of the parts in the latter case. Note that Figure c obviously results in a better loading of the system than the single cycle / single phase system in Figure a. Figure d shows a multi cycle / multi phase system, and finally we have included Figure b, our definition of a basic unicycle PBC system that is single cycle, single phase, and single offset time. We already discussed this figure in Section § 3.1.

Burbidge divides the year into periods, e.g., calendar months. The required production quantities in a period are determined for each end product. A manufacturing throughput time of two times the period length is used. Burbidge denotes this manufacturing throughput time as the standard ordering schedule. Figure 3.12 presents the essential features of the system. From the accompanying explanation in his book, we know that the first month of the throughput time is used for producing part requirements. These parts are all released at the start of this month and are assumed ready at the end of the first month, but their progress is not explicitly monitored through PBC. Next month, the end products are assembled. We see that Burbidge introduces the single cycle system characteristic at ordering level that is essential for PBC, and also, but less explicit, the single offset time and single phase principles. Customer lead time includes the delivery to the customer.

Assembly programme									Year: 1957			
	Jan	Feb	Mar	Apr	May	June	July	Aug	Sep	Oct	Nov	Dec
Product A	30	30	30								30	27
Product B				26	28	28	28	16	28	28		
Product C	12	12					12	7				
Product D			16	14								
Product E									16	16		
Product F					35	35					35	30
Total	42	42	46	40	63	63	40	23	44	44	65	62



**Figure 3.12 Essential features of period batch control (Burbidge, 1962)**

If we compare PBC with the standard batch control system that Burbidge proposed in 1960, we see that PBC requires more calculations. The standard period length of PBC makes it necessary to determine each period the exact balanced ordering requirements based on the explosion of the parts lists. With standard batch control, these calculations had to be made only once if the batch size for an end product was determined. With PBC, the production quantity for each period is determined in the assembly program and may vary per period, as shown in Figure 3.12. There is no cyclic repeating occurrence of requirements for each end product in the assembly program. This illustrates that the PBC system description of Burbidge (1962) is a system that is *not unicycle*, as it is *not single cycle at programming level*.

### § 3.3.3 PBC system design

The description of period batch control shows that in 1962 his attention was directed towards the design of a system that could be used in co-operation with other systems, such as statistical inventory control. The system description is single cycle at ordering level, but not at programming level. Such systems face loading problems. This necessitated Burbidge to pay attention to the design of an adequate capacity control function at programming level. He also proposed to make some parts or products to stock in order to balance loads in the system and allow short throughput times. Burbidge (1962) proposed the following set of decisions for PBC system design:

- 1 The product units that are used for planning purposes in the assembly program.  
These units need not be final products that are sold to a customer. The unit definition serves a planning purpose. The positioning of the CODP (Customer Order Decoupling Point) may lead to the situation that final assembly of the product units into a product for the customer is performed during the sales period, making it more appropriate to use non-finished product entities as planning units in the assembly program.
- 2 P: Period length determination:  
Burbidge proposes to use calendar months or four-week periods. Any other equal division of the year can serve, as long as stock turnover rates are acceptable and the division is convenient for accounting purposes.
- 3 Selection of parts to be excluded from control with PBC:
  - Parts with very long lead times, so that they do not influence the length of the general supply schedule.
  - Parts that require higher turn over rates (expensive or bulky items).
  - Low valued units with even consumption rate, which can be controlled safely at a lower cost with stock control methods.
  - Common parts that can be made to stock in order to reduce the total throughput time.
- 4 Selection of processes to be excluded in the ordering schedule.
- 5 T Selection of the length of the ordering schedule (i.e., total throughput time T)
- 6 N Subdivision of the standard schedule into N stages:  
Burbidge [1962: 293] notes that if items pass through a number of different production departments *'it is necessary to divide the standard schedule into subdivisions, allowing a set time, for example, for obtaining purchase deliveries, or for moulding in the foundry, and the remainder of the standard schedule time for machining. For simplicity this division is normally made on some arbitrary basis so that all castings, or all purchased special materials for example, fall due on the same date. This means that the foundry as well as the machine shop will both have set target dates on which to complete all their work on a batch.'*

The decisions pay attention to the division of the standard schedule into several stages, but it is not explicit on when and how to determine such divisions, and what consequences this will have on the capacity utilization in these parts of the production system. The ideas on the stage decomposition stem mainly from the description of the related standard batch control system in the same book.

Finally, although Burbidge (1962) pays in this publication much attention to production characteristics (mass production, line, batch, jobbing, contracting) and layouts (functional, group, and line layout), he does not consider group organisation to be a prerequisite for PBC. The opinion seems to be that whatever organizational division is applied, the design of PBC has to be such that it gives the required support.

### § 3.3.4 Group Technology and PBC

In 1971, Burbidge's view has changed with respect to the appropriate control system for batch production. Burbidge [1971: 405-406] argues that

- a single cycle ordering system with a short cycle and a standard machine loading sequence is a prerequisite for successful control with group technology<sup>7</sup> and
- such a planning system can only be completely successful if group technology is used

His reasoning is mainly based on the idea that modifications are required in both the controlled system and the control system simultaneously. These modifications have to be in line. The design of the total system has to be reconsidered in order to find real improvements. Therefore (notwithstanding the somewhat doubtful quality of reasoning that Burbidge uses for the strong statements), we consider this to be an important step in the design of PBC systems.

The change in Burbidge's thinking about the applicability of cyclical planning systems in batch production may well be influenced by the work of a group of Russian researchers in the 1960s that became available in English in 1966 (Mitranov, 1959) and 1968 (both Ivanov and Petrov). Ivanov and Mitranov have contributed to the study of required modifications in production systems in order to enable production in groups, such as application of classification and coding schemes, and design of tools to reduce set-up times.

Petrov (1966) was one of the firsts who contributed to the thinking on redesign of the planning system when group production was applied. He performed research in 81 metal ware firms in the St Petersburg that had adopted group technology production principles. These firms used 137 flow line cells and had installed these groups following the central economic plan of the Russian government for the period 1963-1965, which ordered that more use should be made of group production structures. Petrov concluded that *'in the vast majority of group flow lines in operation, production is very far from being rhythmic, parallel or proportional, and the problems of materials and technical supplies have not been solved correctly. Basically this arises from the lack of co-ordination between production engineering aspects of flow line design and its organizational and planning aspects. ... The real saving to be achieved by adopting group techniques is for most part determined by the success or failure of the system of production organization and planning.'* (Petrov [1968: 9, 13]).

Petrov suggests several principles that should be followed when designing an appropriate planning system for group production. He proposes to take as starting point for planning system design the characteristics of the group structure in terms of specialization, required co-ordination, and internal structure. Next, he reconsiders the applicability or suitability of a

---

<sup>7</sup> Burbidge (1971) defines *group technology* as the total of measures to be considered in order to make batch production profitable when using the particular basic solution of group layout. These measures could either try to simplify the material flow system, centralize responsibility for components, reduce set-up times, or reduce throughput times.

group structure in the specific situation with respect to the expected loading of the groups over time. This loading should be sufficient, both on the short and long term, in order to be able to load the various workplaces in the groups evenly. If this can be guaranteed, the following principles should be used when designing a planning system for group production:

- Principle of *synchronization*: the completion of one stage in production and the initiation of the next should be co-ordinated and synchronized. This generates a rhythmic production.
- Principle of *proportionality*: batch sizes or run frequencies of components should be either the same or a multiple of the one used for the products that require these components. Proportionality should be maintained throughout every stage and operation of the production process.
- Principle of *limitation*: the number of different ordering cycles in the system should be limited as far as economically can be justified.
- Principle of *cost balance*: the costs of operating the planning system should be balanced with the cost of operating the production system. Not only strive for rhythmic production and minimum cycle time, but also minimal set-up time and maximum batch sizes to obtain high productivity and low labour costs.
- Principle of *loading stability*: the loading of the groups, shops, sections, and work places, should be stabilized through a correct distribution of the total load over successive time intervals in order to generate a steady output.

The five principles of Petrov direct attention to the advantages of cyclical planning within group production. The particularities of this mode of production place other demands on the design of planning systems. The usage of these principles may help to improve planning for group production, but the set of principles is in itself not consistent. However, PBC system design in Burbidge (1971) did benefit from this description, amongst others with respect to the design of the standard ordering schedule and its subdivision through production flow analysis. The synchronization principle resulted in a more strict phasing of the stages that were distinguished.

### § 3.3.5 Stable loading and single cycle programming

The work of Petrov also provides insight in an important facet of group production, namely the increased sensitivity for loading imbalances. This imbalance can sometimes be tackled by the increased multi functionality within a group, but the loss of pooling synergy, as described by Suresh and Meredith (1994), remains a problem that has to be taken into account when designing a production planning system for group production.

Petrov's cyclical planning system was not single cycle at programming level, resulting in a surge effect as described in Figure 3.3. Descriptions of other cyclical planning systems, applied during the 1960s in Dutch companies such as Philips (see e.g. Botter [1967:chapter 7])

and Ham [1969:chapter 5,6]), give the same impression. The systems described in these publications use a fixed period between the issuing of new orders for a type of product, mainly to improve the detailed production planning. However, the cyclical systems in the Netherlands operated with rather long cycles and faced a number of fundamental problems, such as many disturbances, many urgent orders, high inventories, long throughput times, and a low lead time dependability (Monhemius, 1989). Improvements for these systems were sought in the development of more advanced statistical inventory controlled systems instead of searching for improvements in the fit between the controlled system and the design of the control system. The organization of the production system itself became no subject of study, and many of the researchers were more fascinated by the increased possibilities of applying computers and operations research techniques, a trend which we have described already in Chapter One.

In England, the development of cyclical production planning systems did continue with the work of Burbidge (1975a) and New (1977). Here, the attention also focussed on the advantages of finding optimum loading schedules for groups in case of repeating patterns. However, they concluded that these repeating patterns would more often occur if the planning system would become single cycle at programming level as well. If each product would be ordered each cycle, the loading of the system would only depend on the variety in the volumes required per period, not on the amount of set-up time needed. The planning and preparation of the set-ups could be performed in advance such that high learning effects could be achieved. Set-up times were therefore not considered to be fixed, but could be influenced by the cyclical planning system. The same would hold true for the utilization of raw material. They believed that grouping of work orders requiring the same input material for their first operation would introduce new batching possibilities. Economies of scale would therefore still be achievable.

Burbidge (1975a) noted that in a single offset time, single cycle system at programming level, loading is easier to accomplish, because of the direct relationship between actual capacity requirements and production periods. Regulation of capacity through overtime working or outsourcing may still be required and is decided upon within the program meeting. The possibility of a transfer of work men between groups is considered only in severe cases. PBC requires additional control mechanisms for correcting stock positions due to higher or lower yields than expected, or to errors in the scrap and spares forecasts [1975a: 95]. This also leads to possibilities for regulating capacity requirements.

In order to develop optimum loading schedules for the single cycle system at programming level, standard sequences were proposed. Burbidge calls this cyclic planning, and the figure that he uses is presented in Figure 3.13. He describes a flow shop (each work order may have different processing times, but requires processing in the same sequence at all work centres). The loading sequence that he applies is a permutation schedule. Note that a permutation schedule need not be optimal with respect to make span minimization in case of a flow shop with more than three machines.

A standard loading sequence is designed

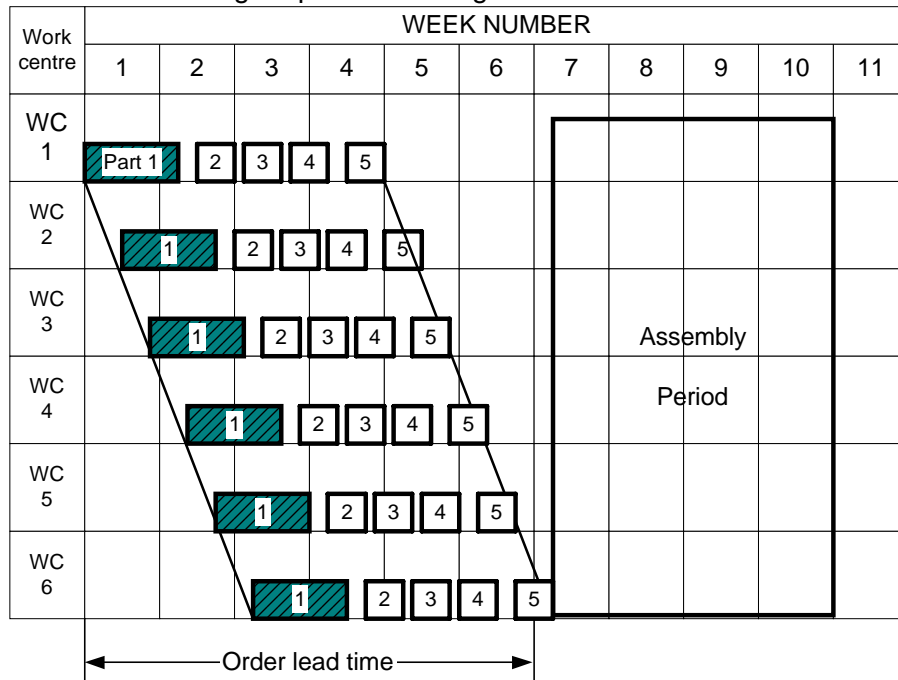

This standard sequence is repeated every cycle

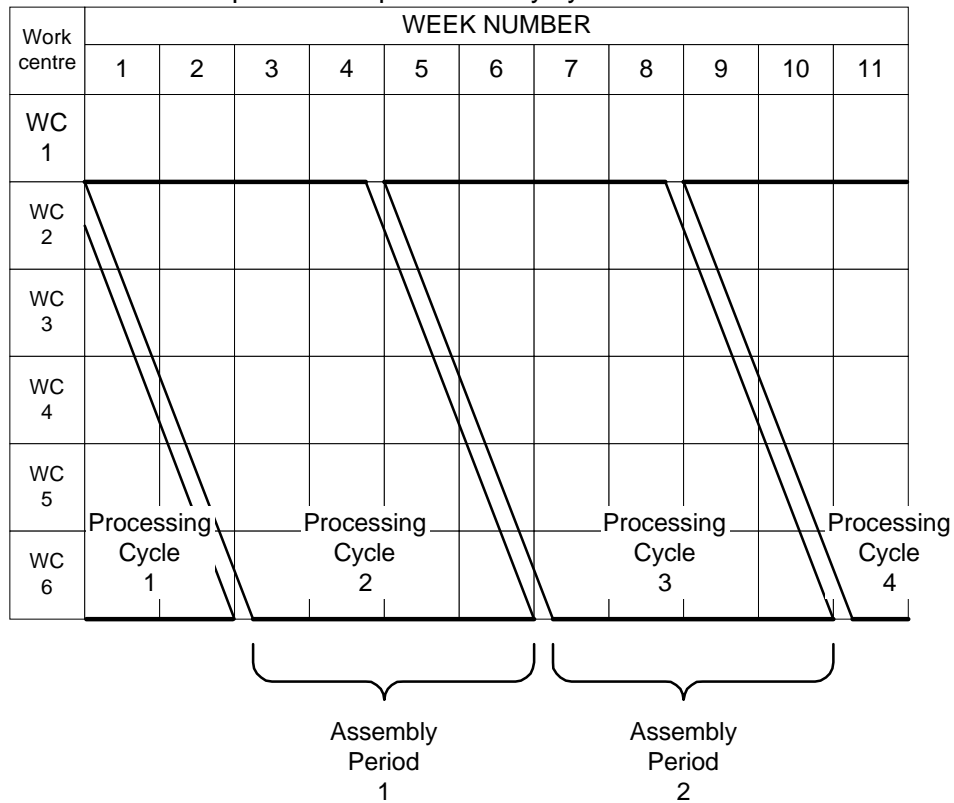

Figure 3.13 Cyclic planning according to Burbidge [1975a: figure 3.6]

§ 3.3.6 Overlapping production and multi phase cyclical planning

The loading sequence as presented in Figure 3.13 shows that the next work centre already starts with a work order while the same order is being processed at an earlier work centre. This is the first time overlapping production, or *close-scheduling* (the term used in PBC literature), is being introduced in the description of a cyclical planning system. The organizational impact of such a measure is quite high, so it can only be applied if the successive work stations are able to co-operate in the quick processing of the complete work order. Both the application of a group layout and the learning effect that leads to a reduction in throughput time facilitate the successful application of overlapping production for at least some critical components.

Another remarkable aspect of Figure 3.13 is the parallelogram that arises in the processing cycle. This parallelogram implies that each *work centre* operates with a cycle length of four weeks (a single cycle, single offset time system for work centres), but the order lead time in the processing *stage* is six weeks instead of four weeks. It is therefore not a single cycle, single offset time system for the co-ordination of successive stages. The assembly stage starts in week seven, which probably means that all five work orders have to be ready before assembly can start. Assembly takes four weeks; it is depicted as a rectangle instead of a parallelogram.

The cyclical system that is described is not a single phase system. Each work centre receives the work of a cycle on another moment in time, but obtains a full cycle of four weeks to finish this work. The cyclical planning system operates therefore without a fixed synchronization moment or mechanism. The decision space of a work centre is very restricted in such a multi phase cyclical planning. It is not possible to change the sequence of work order processing without negative consequences for the make span of the whole set of work orders at the last station, as long as the loading of the system is as high as shown.

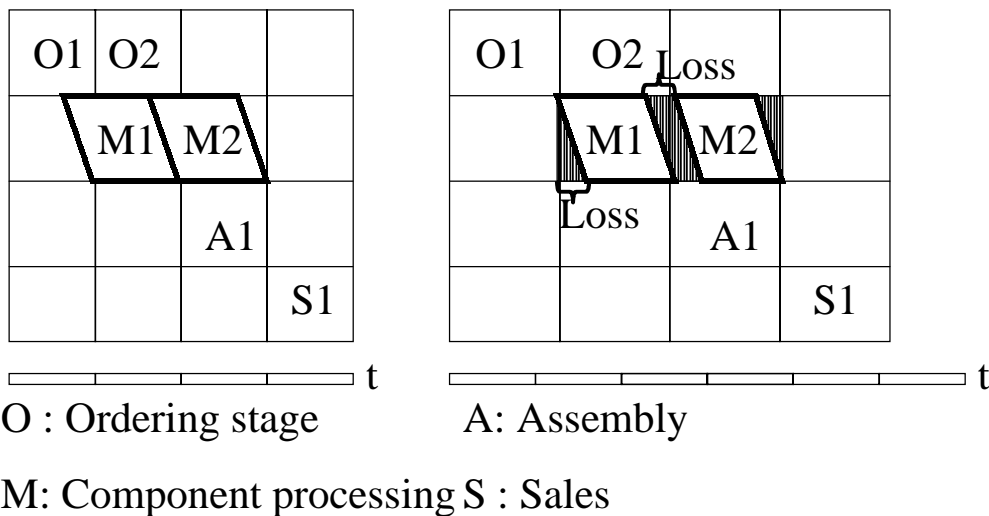

Figure 3.14 Flow shop cyclical planning

Burbidge [1975a: 81] describes that there are in general two possibilities for the problem of flow shop processing in the component processing stage. These are depicted in Figure 3.14. The left figure shows the same pattern as in Figure 3.13. During the ordering stage O1, processing already starts in M1. Ordering of the parts required at the first machines has to be speeded up, as less than the available period length is available for ordering. This solution cannot easily be applied in case of a (sub)assembly stage, as the availability of all materials is required at the start of this processing step.

The alternative is depicted at the right side in Figure 3.14. The period length has been increased, in order to be able to complete the whole set of work orders within one period. This has led to an increase in the throughput time as well as in the volumes to produce each period. The losses are accepted as an allowance for late work and to provide capacity for rush orders and other additional work, as Burbidge notes.

### § 3.3.7 Information technology and PBC

The contribution of Collin New (1977) to the thinking on cyclical planning systems has been important. First, he discusses the changes imposed in PBC planning system design by the possibilities of computerized support. He considers the argument of designing a system with as simple calculations as possible no longer to be valid. The introduction of the computer makes it easier to design tailor made planning systems where specific product types are treated differently within the same system concept. Parts with extremely long or short throughput times, expensive items, and items that are produced with uncertain yield, and so on, can more easily be controlled by the application of specific planning principles.

Notwithstanding the above, New favours the application of single cycle systems, particularly period batch control, when coupled with group production. The administrative tasks with respect to the bills of materials, and the determination of parts requirements (explosion and allowance calculations) should be provided by computers, but the role of the computer in actually controlling work order progress would still be marginal. With group production, the information requirements on actual work order progress would be lower compared with functional organized production. Therefore, group production supports a more appropriate distribution of computerized planning tasks and human planning tasks. The PBC system that New proposes is a unicycle period batch control: single phase across all products, and single cycle at *both* programming *and* ordering level. This single cycle causes a repeating pattern in the loading of the groups, which enables them to determine a planned loading sequence of the various machines, possibly with the aid of a computer. This re-usable planned loading sequence might include overlapping machine operations and planned usage of family set-ups.

New suggested to integrate the strengths of group organization, cyclic planning, and control procedures from material requirements planning systems in order to contribute to the improvement of component production. His introduction of the unicycle PBC concept is

important in the development of thinking on cyclical planning systems. His reasoning on the combination of computer power, cyclical planning, organizational decomposition, and allocation of responsibilities and planning tasks, is more precise than the one offered by Burbidge. However, he does not really contribute to an appropriate design of a PBC system. Stage definition, raw material achievement, and period length setting are not treated in depth.

Suresh (1979) describes the applicability of New's ideas for an automobile ancillary industry firm in India. The firm used to produce components in a monthly cycle. A successful introduction of a MRP system should take into account the possibilities of using group production and simplifying the production control system. Group production would enable the firm to produce with much smaller and predictable lead times. A cyclical planning system would reduce throughput time and simplify loading decisions. The basic requirements of a computerized planning system, like the proper structuring of the Bill Of Material, realism of the master schedule, and accuracy of the inventory records, would remain unchanged as compared with a direct introduction of an MRP system. From a systems engineering point of view, a PBC system could be introduced using standard available MRP software. The 'parameterisation' of this software would either or not make it a unicycle PBC system.

Burbidge (1979) fears that using a computer in order to centrally determine schedules for coordinating the flow within the groups results in undesirable effects. This task can better be performed within the cell, as relevant information is available at this level, and the effect of measures can be seen directly. Information at central level is often less accurate, less precise, and less timely available. If the opportunity to plan and control the work within the cell is given to the cell, this often increases workers job satisfaction. He does not discuss the setting of PBC system design parameters in order to make these decision processes more effective.

Hyer and Wemmerlöv (1982) are very critical on the applicability of cyclical planning systems for cellular manufacturing. They formulate five points of criticism. In their opinion, (1) the sensitivity of a cyclical planning system for demand fluctuations is too high, causing the system to suffer from unacceptable over- or under-capacity utilization. They assume that the low level of sophistication in the usage and understanding of computerized planning systems in British industry has led to the propagation of using simplistic production planning procedures that are only attractive in combination with cellular manufacturing.

They state that one of the drawbacks of using PBC in connection with manufacturing cells is (2) the absence of clear guidelines for determining the correct cycle length. Furthermore (3), they think that, regardless of the specific cycle length, there may exist an inherent capacity imbalance between component production and assembly, as both processes need not require the same cycle time to produce the required products for a specific cycle. Note that the latter comment is clearly a misconception with respect to stage definition within PBC, which allows more stages for component production if required.

Wemmerlöv and Hyer are very critical on (4) the applicability of planned loading sequences. They argue that literature on PBC has not proposed specific methods for generating such sequences, neither has it considered the consequences of mix variety or lumpy demand for these sequences. Only if the cycle length becomes sufficiently small, such as in Japanese production planning systems for cellular manufacturing, the PBC cyclical planning system comes close enough to these systems and may become appropriate for cellular manufacturing.

Finally (5), the problem remains on the use of two planning systems simultaneously, one for the cellularized part of the firm (PBC) and one for the non-cellular part of the firm (traditional MRP). They refer to their experience, which had shown that firms did only allow minor changes in the production planning system when changing towards cellular manufacturing.

The work of Hyer and Wemmerlöv (1982) has had a strong impact on later research on planning for cellular manufacturing in the United States, considering the number of citations it received. However, two years later another influential publication on cyclical planning systems occurred from Whybark (1984), one of the leading researchers in the USA on MRP system design. We already discussed his system for the Finnish Kumera Oy in Section § 3.1.4 and Figure 3.6. Whybark found an increase in inventory turnover, delivery accuracy, and margins. The factors that counted for these benefits were: a simple planning system, easy to implement, easy to work with, and easy to improve according to suggestions of the users. He views the cyclical schedule as a train schedule<sup>8</sup>. He directed the attention in planning system design not only towards accurate information and planning tools, but also to accurate order acceptance and co-ordination between production, sales, engineering, and management.

The renewed insights on cyclical planning systems were included in Wemmerlöv (1988), an APICS book on '*Production planning and control procedures for cellular manufacturing*'. This publication gave a less pessimistic and more accurate impression of the strengths and weaknesses of the applicability of cyclical planning systems in cellular manufacturing. Wemmerlöv favoured the cyclical system that was applied by Whybark over the more rigid basic unicycle PBC system. His argument was, that PBC omits an instrument for co-ordination within or between cycles with respect to the sequence, while the use of these planned sequences seemed him to be a major justification for the use of PBC in cellular manufacturing. We think this is not a valid argument for favouring Whybark's system over PBC. First, the sequencing problem within a cycle in the Finnish system is more problematic than in standard PBC, due to the multi phase system that was introduced and the absence of a synchronization mechanism between the release moments. Second, sequencing between cycles is adequately performed through the synchronization mechanism of PBC. Whybark's system uses the same mechanism between parts production and assembly.

---

<sup>8</sup> Apparently this metaphor presumes a well operated train system, in which trains that have departed do not return for late passengers, and do ride according to their time schedule.

With respect to the simultaneous use of PBC in combination with other systems, such as MRP and Kanban, Wemmerlöv (1988) noted that PBC could be combined with a pull system such as Kanban for order execution. The use of PBC for companies with an MRP would make it necessary to change mainly the way of working instead of change the type of computer support system. Wemmerlöv therefore recognizes that the benefits of a cyclical planning system, based on repetitiveness and constancy, can be achieved through the combined usage of elements of PBC, MRP and Kanban.

Burbidge (1988) pays attention to the consequence of the occurrence of bottlenecks within the cells for PBC systems. The OPT system of Goldratt (1980) seemed to be an alternative for a cyclical planning system such as PBC. In case of bottlenecks in cells, the loading sequence within these cells becomes very important, as cyclical planning system require that all work has to be finished at the end of the period. If other machines have to be visited before the bottleneck can start processing, this incurs even some start losses for the bottleneck. The same holds true at the end of the period (finish losses). Burbidge suggests that this situation can be handled within PBC by appropriate scheduling of the first and last activities, and of the bottleneck activities. For this purpose, specific tools should be made available within cells.

Burbidge does not criticize the bottleneck scheduling method of OPT, but the overall planning method is not copied into the PBC framework. He suggests to use OPT for determining planned loading sequences at the bottleneck. We consider this to be a misconception of Burbidge with respect to the significant consequences of using the OPT scheduling method for preceding and following processes. Further, note that Burbidge does not try to decouple the bottleneck process from other processes in the cell or system. He leaves the definition of a work order and the cyclical character of the planning system unchanged if bottlenecks appear.

### § 3.3.8 Cyclical planning to improve rather than just co-ordinate production

Hall (1988) considers the application of cyclic schedules as a major step in actually achieving both improvements in manufacturing organization and close synchronization. His publication positions cyclic scheduling as a vital concept in the framework of continuous improvement. The contributions expected from cyclic scheduling systems are amongst others:

- improved supply chain co-ordination
- elimination of causes of disturbances instead of reacting to disturbances
- improved introduction of engineering changes on effective dates that correspond with the predetermined release moments of work orders
- increased consciousness of internal client/server relationship between successive cycles

In order to develop repetitive manufacturing, Hall states that the cyclic schedule and the transformation process must be developed symbiotically. Furthermore, both will evolve over time. This will have consequences for the length of the schedule period. Shorter scheduling periods result in more required flexibility, due to short term variations in customer demand.

Hall notes that the length of production cycles should not be determined based on preferred cycles of internal accounting reports, or sales departments. The production system improvements can only be found if the cycle length is determined with respect to the supply chain characteristics, both internal and external of the firm.

Halls's cyclic scheduling system is not particularly a PBC system. Many of the ideas stem from the Japanese systems that apply multi phase, very short but multi cycle systems. Still, the notion that cyclical planning systems help to improve the transformation process instead of simply co-ordinate these processes meant an important step in the development of thinking on cyclical planning systems. This notion differs from the line of thinking on MRP system effectiveness, that evolved in terms of data accuracy, system reliability, and degree of actual usage, resulting in classifications of users as class A, B, C, D firms, see e.g., Wight (1984).

The renewed interest in cyclical planning systems, both in industry and research community, resulted in theoretical progress and combination of insights from several branches of research. Methods that were developed for multi item lot sizing, capacity constraint scheduling, sequencing, and synchronized flow production were partly integrated. Luss (1989) showed that the smaller the length of the production interval in the first stage, the more effective the synchronization in the system. Shtub (1990) argues against the assumption of PBC that discrete demand lot sizing policies are not cost effective in cyclical planning systems. He develops a heuristic lot sizing procedure based on the traditional trade-off between set-up costs and inventory costs. His work received attention of Jamshidi and Brown (1993) and Rachamadugu and Tu (1997), who continued the research on other lot sizing approaches within a PBC framework. They do not use a single cycle ordering approach for all products and parts in the system, but search for common cycles for *subsets* of parts and products.

Other research on cyclical schedules, such as Loerch & Muckstadt, 1994, and Ouenniche & Boctor, 1998, direct attention to the determination of suitable production cycles in combination with appropriate (powered nested) batching policies. From a theoretical point of view, their work attempts to fill the gap that was earlier identified with respect to the planning and sequencing problem within cyclical systems such as period batch control systems.

In Germany, Habich (1990) examined the consequences of the introduction of group production for work order release and the type of planning within and between groups. He concludes that the design of the co-ordination between the autonomous production groups is essential for obtaining the desired benefits of group production. A cyclical operating co-ordination system enables an increase in flexibility and autonomy of the groups. Cyclical planning systems provide transparency and enable the development of appropriate planning tools for specific groups. Such tools may help to estimate required capacity, or to represent work order routings within the group graphically. The characteristics of autonomous groups and their coexistence within one production system results in the specification of requirements for the planning system. Co-ordination improves if the decision moments on work order release are in phase.

### § 3.3.9 PBC, MRP and Kanban

At the end of the 1980s, a number of papers appeared that compared the performance of MRP systems and several variants of it with Kanban. The relationship between this performance and the manufacturing organization was being studied (e.g., Schonberger, 1983, Krajewski, King, Ritzman, & Wong, 1987). Wijngaard (1986) propagated the need for a contingency approach in finding appropriate methods of planning for specific situations. A contingency approach ascertains the strengths and weaknesses of each system. This redirected attention towards the properties of the PBC system. Many of the publications had favoured Kanban systems for the low inventories and short throughput times, but the period batch control system was said to achieve the same performance if combined with group production. Therefore, PBC received renewed attention from the research community as a consequence of the broad interest in cellular manufacturing in western industry and the conquest for finding production and market characteristics that favour particular planning and control approaches.

A number of papers appeared that compared PBC with MRP and Kanban, e.g., Yang & Jacobs, 1992, Kaku & Krajewski, 1995, and Steele, Berry, & Chapman, 1995. The results of these comparisons were contradictory. Yang and Jacobs found that the order release and due date assignment procedure of MRP always outperformed the rigid PBC system. Steele et al. found on the contrary that PBC systems outperform MRP and Kanban systems under specific circumstances with respect to set-up times and variation in the order mix. The contradiction in research outcomes showed that the decisions on the specific design of the systems that were compared and the inherent assumptions that were made in building the simulation models first had to be made explicit and studied on their own. Former studies often selected PBC design parameters for similarity with MRP or Kanban practice.

Rees, Huang and Taylor (1989) already had paid attention to the design of the systems they compared. They studied the possibilities to achieve the same cycle times within an MRP system by applying lot for lot batching (L4L, i.e., single cycle at ordering level). They did not introduce a single offset time in their MRP L4L system, which distinguishes it from the basic unicycle PBC system. The performance of Kanban was compared with MRP L4L if both were operating under almost equal conditions, with identical short cycle times. The simulation results showed that the cyclical operating MRP L4L system generated greater savings than the Kanban system, in spite of the fact that some MRP offset times were longer than the Kanban throughput time. If MRP and Kanban were both implemented at the same number of cycles per day, the results favoured MRP L4L because it required fewer set-ups *and* less inventory.

The research of Rees, Huang and Taylor (1989), and the contradictory result of the comparisons of several systems renewed the interest in an appropriate design of cyclical planning systems as PBC. Wemmerlöv (1979) already had pointed towards some important design factors of MRP systems. He concluded that the selection of the time bucket length, offset times, cycle times, and the structuring of the bill of materials could help to improve overall system performance.

Steele and Malhotra (1994, 1997) provided an important contribution to the identification of PBC system design factors. The design factors that they proposed were: period size and transfer batch size. They asserted that MPS load variation and capacity imbalance would have important influence on the performance of a PBC system. The design of the PBC system should depend on the delivery performance of the weakest element in the chain. Furthermore, the PBC design would be affected by the possibility of adjusting capacity, and by the length of the customer order lead time that would be acceptable in the market.

The list of design factors of Steele and Malhotra (1994, 1997) is created under the assumption that the structure of the production system is known when designing a PBC system. They assume a direct relationship between cells and PBC stages and therefore use a constant number of stages. Finally, they assume an important effect of PBC system design choices on the capacity adjustment property of the planning system, but they do not identify the influence of the relationship between cellular structure and PBC system configuration on this system property. The conclusions on the sensitivity of PBC performance for several sources of variation may well be affected by the presumed strong connection between production system and planning system structure.

#### § 3.3.10 Concluding remarks

The evolution of the PBC system reveals that the three principles single cycle, single phase and single offset time have gradually emerged. Many changes in the PBC system have been considered during the last decades. The causes for these changes are the same as described in Chapter One: advances in information technology, planning theory, changes in required internal or external performance, and so on. Cyclic planning systems such as PBC still receive attention for their transparency, improvement potential, and suitability to support flexibility and autonomy in cells. PBC has been compared with planning systems as MRP and Kanban.

The contradictory results of the comparative simulation studies have shown that the *design* of the PBC system is an important determinant for performance improvement. Design problems that have been studied are the relationship between period length and batching policy, the relationship between production and planning system structure, and the development of capacity adjustment policies. However, these studies assume certain characteristics of the PBC system without considering the issue of determining appropriate values for the design factors in PBC system design. A too restricted view on PBC performance and possibilities results. Therefore, the problem of how PBC design choices affect performance and how this performance is influenced by several sources of variation remains poorly understood.

### § 3.4 Outline of research on Period Batch Control system design

The design of a PBC system requires careful examination. Our critical examination of studies on PBC system design and the design factors that were proposed in literature brings us to the main question of the remaining part of this study:

*What choices have to be made  
when designing a basic unicycle Period Batch Control system  
for the co-ordination between cells  
and how do they affect performance?*

Chapter One and Two have described some general factors for planning system design for cellular manufacturing. In order to obtain an effective period batch control planning system, we have to identify additional factors that relate to the essential characteristics of the PBC system itself. Section § 3.3 has shown that the contribution of several important aspects of planning system design, such as the period length, bill of material structuring, and the use of transfer batches (overlapping production), is often studied independently from other aspects of the design of production systems.

The purpose of the remaining part of our research project is to improve our understanding of the relationship between production system design choices (the specificity's of the cellular manufacturing system) and PBC planning system design choices. We want to identify and analyse the contribution of the various design factors on the effectiveness of a basic unicycle PBC system.

Chapter Four will identify the main factors that have to be taken into account when designing a basic unicycle period batch control system. It studies the interrelationship between factors in both production and planning systems and their influence on system performance. Finally, it discusses the determination of suitable values for PBC design parameters, such as the period length  $P$ , the number of stages, and the definition of stage decoupling points.

In Chapter Five, we will pay attention to the development of methods to determine the period length in combination with the use of planned loading sequences. We develop mathematical methods that support the determination of suitable values for the period length and the number of transfer batches in the system, and we show the effect of varying either of these parameters. In this chapter, we consider the number of stages to be a result of the choice of period length and the batching policy applied.

Literature on PBC stresses the importance of determining PBC system parameters in order to reduce the manufacturing throughput time. In Chapter Six, we test the influence on system performance of varying both the number of stages  $N$  and the period length  $P$  for various batching policies while the manufacturing throughput time remains constant. The simulation

analysis that we apply examines the effect of varying these system design parameters on the amount of overtime work and costs for cellular production situations.

Chapter Seven studies the design process of a PBC system. The applicability of the methods that we developed in Chapter Five for determining a configuration for the PBC system is considered. We compare the performance of the proposed configurations with the configurations that we simulated in Chapter Six.

Chapter Eight considers the effect of different designs of a PBC system on the co-ordination requirements between cells in the cellular manufacturing system. These co-ordination requirements are related to the type of uncertainty. We examine the effect of PBC system design choices on the occurrence of this uncertainty within and between cells. The co-ordination that PBC provides may be insufficient if we encounter relationships between cells within a stage. We introduce the notion of stage co-ordination in order to fill this gap.

Finally, Chapter Nine presents the conclusions of this study and provides some recommendations for future research.

This study does not aim at presenting the basic unicycle PBC system as the major production planning system for cellular manufacturing. There are many situations in which other systems will be more appropriate. The rigidity of the PBC system that we examine is in most cases too strict to be of direct practical use. Developments in the field of information technology might enable firms to control the problems of planning system nervousness, loading imbalances, and lack of transparency of work progress alternatively and possibly more efficiently as compared to using a PBC system.

However, cyclical planning is still a very interesting approach, favoured in lots of work on production planning systems as shown above. It enables firms to focus their attention on system wide improvement of the co-ordination of their production system. Firms that apply such a planning system may benefit from the insights that are generated in this study to find a more appropriate design of their system. We view the PBC system as a stripped MRP planning system, as it uses equivalent co-ordination principles. It is a less rich approach, as it allows fewer decisions about system design parameters. This makes the applicability of PBC more restricted compared to MRP. However, the decisions that have to be taken in a PBC system are equally important in alternative planning systems. Therefore, studying the PBC system will be relevant for academic researchers that are involved in evaluating alternative planning system approaches as well. It will enable them to improve the design of proposed planning systems before attempting to compare their effectiveness with other systems.



---

## Chapter 4 Design factors for basic unicycle PBC systems

This chapter discusses the main factors that have to be taken into account when designing a basic unicycle period batch control system. Section § 4.1 will show that designing a planning system cannot be isolated from designing a production system. We will therefore examine the mutual relationship between PBC system design choices and production system design.

For the design of a basic unicycle PBC system, the length of period is an important design factor. Section § 4.2 focuses on the determination of this period length  $P$  in a PBC system. The relationship to the production structure is explored and factors that have to be taken into account when determining the period length are distinguished.

Stage definition is the other important design factor for PBC systems. Stage definition consists of two separate decisions: setting the number of stages  $N$ , and determining the contents of the stages. They will be discussed in the next two sections.

Section § 4.3 discusses the number of stages  $N$ . We examine the relationship between the structure of the production system and the decomposition of the planning system into  $N$  stages. This helps us to identify aspects that affect the decision about this number of stages.

Section § 4.4 elaborates upon the contents of the stages. It discusses the relationship between cells (WHERE operations are being performed) and stages (WHEN operations are being performed). We will provide a mathematical model to offer guidance on deciding how to appropriately allocate operations to the stages.

The chapter ends with Section § 4.5, which provides a summary and conclusions. At the end of this chapter, the first part of the third research question will have been answered, i.e., we will have shown what choices have to be made when designing a basic unicycle period batch control system for co-ordination between cells.

### § 4.1 Concurrent design of production system and planning system

A production system consists of various elements: machines, operators, tools, and handling equipment. These elements are organized in such a way that the system can transform input (material) into desired output (products) within a period of time. The structure of a production system is determined by both the characteristics and the organization of the elements of the system. This includes the layout in the factory, the organization of the material flow through the factory, and the allocation of tasks to operators.

A production system is co-ordinated using a planning system. This planning system prepares the decisions with respect to the utilization of the production system over time in order to

achieve the required performance with respect to speed, dependability, flexibility, quality, and costs. Information is the input for the planning system. Planners, computers, and other information bearers are elements of the planning system. The various tasks that are performed by these elements of the planning system are organized in such a way that the system is able to obtain the desired output (a plan) to fulfil the higher-level system objectives. The structure of the planning system is determined by the characteristics and organization of these elements. More specifically, the planning system structure shows what planning tasks when, where, and by whom will be performed. The planning system decides what to make when and where in the production system.

### § 4.1.1 Relationship between production systems and planning systems

The design of a suitable structure for the production system and the design of the structure of the planning system are interrelated. This relationship is often considered unidirectional, e.g., first determine the production system structure and then the planning system structure can be deduced. Figure 4.1 shows this traditional unidirectional conception of a design process.

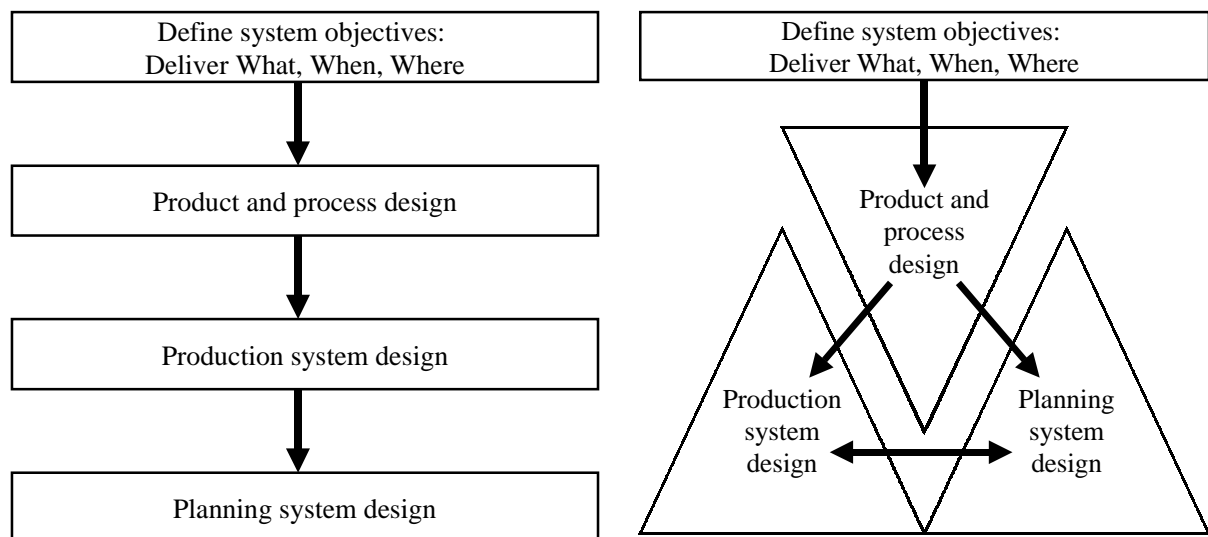

Figure 4.1 Traditional sequence design process Figure 4.2 Mutual interaction between design of production and planning system

Although this sequence is often applied, we should not consider the relationship between production and planning system design to be unidirectional. To understand this relationship, we should take into account the origin of the data used to determine the structure of both systems. This data originates from product and process design. We will clarify the role of this data in the design process by examining the interaction between both systems.

Figure 4.2 shows our view of the interaction between the design tasks. It includes all traditional relationships, but adds some important new relationships as well, especially with planning system design. The relationships within this figure will be discussed.

In order to design a system, we firstly have to identify the function of the system. This helps us to determine the activities that have to be performed in both the production and the planning system. We can specify the function of the system in terms of *what* to produce *when* and *where*, i.e., in terms of the system objective. This strategic decision sets several objectives for the planning system, i.e., logistical parameters such as lead time, volume, flexibility. For decisions on these parameters, knowledge is used about the market (opportunities and treats) as well as some elementary characteristics of the production system and planning system (strengths and weaknesses). This results in a basic structure for the logistical system, as it decides on the customer order lead time, which has consequences for the location of the customer order decoupling points, production units, outsourcing decisions, and so on.

Before we can determine in more detail the elements required in the production system, we first have to decide about product design and process specification. These decisions determine the processing functions that will be required in the transformation process, as well as the relationship between these processes (the sequence).

There is often a direct relationship between the specified functions and the available elements in the production system. In these cases, the decisions about product and process design result in direct relationships between elements in the production system, which subsequently influence the structure of the planning system. If elements in the production system are selected that, for example, will bring uncertainty of yield for this operation, the design of the planning system may have to compensate for the negative impact of this uncertainty on the overall system performance. This might lead to the insertion of more buffer capacity between the operations. The traditional direction of interaction from the design of the production system to planning system design will therefore be in force.

However, it should also be observed that a link from planning system design to production system design might be present. The selection of processes and their sequence within product and process design may have direct consequences for the structure of the planning system, which subsequently influences the design of the production system. The system objectives may necessitate that the planning system have a specific structure, which might have consequences for the design of the production system as well.

For example, suppose a processing sequence is specified that involves many different processes and the system objectives require both a high utilization of a bottleneck resource and short throughput times. These objectives can be realized only through an appropriate design for the planning system. Subsequently, this imposes constraints on the design of the production system with respect to a lay-out that enhances the quick transfer of items between successive processes.

The design of the planning system may also require that specified processing steps necessary to perform the transformation be subcontracted or outsourced, although elements of the production system might be able to perform the operations.

After the process planning has been finished, the next important step in determining the planning structure is to configure the planning bill of materials. This configuration matches processing steps with work orders. The specification of work orders is a decision about the planning system structure, as it concerns the release of work to and hence the utilization of the production system. The configuration of the planning bill of materials influences the location of stock within the system. The production system ought to be able to accommodate the stock positions that result from the design of the planning system.

These three examples show that interaction from planning system design to production system design will also be in force.

If the traditional sequence of the design process is followed, the grouping of operations into work orders is based on data that originates from the structure of the production system, as its design precedes the planning system design. However, the structure that is being designed for the production system may not be the most appropriate structure for designing a planning structure. For example, if the process plan specifies a milling operation before a welding operation, the production system design might locate these activities and their equipment in separate functional departments because of the differences in technology. In order to achieve the required logistical performance, the planning system may prefer a different configuration of the production system. The product routing data includes information on the transfer times between two operations within the production system. If this information is based on a functional configuration of the production system, this may influence the grouping of processing steps into work orders. It can result in huge inefficiencies if the planning system releases such work orders very early, as this results in high throughput times.

We conclude that the relationship between the design of a suitable structure for the production system and the design of the structure for the planning system is not unidirectional. In mutual interaction between both systems, decisions should be taken on the material flow and the control of this flow, the subcontracting policy, the specification of work orders, and the allocation of buffers and stock locations in the system. This study considers the relationship between PBC planning system design and cellular organized production system design. We will determine the effect of various configurations of the PBC planning system on these decisions and their impact on production system design.

#### § 4.1.2 Planning literature and production system structure

How does literature on the design of production systems and planning systems take this relationship between planning system design and production system design into account? We have to make a distinction between literature on the design of system structures and literature on the optimization of systems. Scheduling literature (e.g., Conway, Maxwell, & Miller, 1967, Baker, 1974, French, 1982, Rodammer & Preston White, 1988, Wein & Chevelier, 1992, Riezebos & Gaalman, 1998) does not take into account a possible redesign of either the

production system or other parts of the planning system. It is directed towards finding a 'best' way to process certain jobs on one or more machines, but the number of machines or the routing of the products is not considered as a variable. The optimization oriented literature does not provide assistance in the design of the planning or production system.

Literature on the Kanban system (e.g., Sugimori, Kusunoki, Cho & Uchikawa, 1977, Mitra & Mitrani, 1990, Miltenburg & Wijngaard, 1991) generally assumes that the cell structure is fixed, that cells apply a type of line layout, and that the manufacturing processing and throughput times for the products within a cell are known (or at least some characteristics of their probability distributions). The design of the planning system is focussed on determining the number of Kanbans per product per cell (i.e., determining the total throughput time of a Kanban) as well as a level schedule of end products such that the loading of the various cells fluctuates minimally. Kanban literature does therefore take the structure of the production system for granted and designs a planning system without taking notice of the possibilities that are a consequence of the mutual relationship between both systems. More general literature on Just In Time system design (e.g., Schonberger, 1982, Monden, 1983, Hall, 1987) usually includes some general notes on production system redesign and planning system design. It describes some desired characteristics of the production system structure if it is to be controlled with a Kanban system. However, it does not offer adequate support for making congruent decisions on the structure of both systems .

The Optimized Production Technology (OPT) system (e.g., Fox, 1984, Goldratt, 1981) pays more attention to the structure of the production system when a planning system is being designed. The location of the bottleneck in the production system has to be determined before the planning of the rest of the system is undertaken. OPT even prefers specific elements of the production system as bottleneck. Bond (1993) notes that a machine as bottleneck is preferred instead of operators, tools, handling equipment, or buffer locations. The reason for this preference lies in the design of the planning system. The detailed planning and frequent replanning of OPT requires a high level of control of the planning system over the progress of work within the production system. A machine as bottleneck is more easily identifiable, more visible, and the rest of the system can more easily be oriented towards the progress of work on such a machine than in those cases where another element of the production system is the bottleneck. If the production system is modified such that a machine becomes the bottleneck, this can improve the whole system design.

The OPT framework prefers the location of the bottleneck in the chain of processes required to produce the products. This location is generally upstream of the production process, as this leads to less work in progress, smaller cycle times and smaller amplitudes in the waves of work flow. Goldratt (1981) states that *'the resources must be organized such that the bottleneck resource is used primarily at one of the earliest stages of the production process, and not near the end.'* OPT literature therefore recognizes the relationship between production system and planning system design. However, it places a strong emphasis on production capacity and material flow, while other elements of the production system and the

organization of the production resources receive less attention for redesign. Finally, OPT can be used as a tool for simulating, analysing and optimizing production operations, which may help to improve material flows. This literature thus recognizes the mutual relationship between production system and planning system design.

In general, literature on planning frameworks such as MRP I and MRP II (Orlicky, 1975, Wight, 1984, Vollmann, Berry, & Whybark, 1997) is mainly concerned with the function and interaction of the various planning modules within the planning system and pays much less attention to the mutual relationship with the production system<sup>1</sup>. However, it is essential that the planning system uses a correct model of the production system. The structure and characteristics of the production system are used as input for the MRP planning process, for example in the design of the Bill of Material, Bill of Labour, and Bill of Capacity. Orlicky [1975: 207] notes: *'The Bill of material should reflect, through its level structure, the way material flows in and out of stock. The term "stock" in this connection does not necessarily mean a stockroom but rather a state of completion. ... Material requirements planning also assumes that the bill of material accurately reflects the flow (in and out of stock). Thus the bill of material is expected to specify not only the composition of a product but also the process stages in that product's manufacture. ... This is vital for mrp because it establishes, in conjunction with item lead times, the precise timing of requirements, order releases, and order priorities'*. The benefits of an interaction between both design processes are not recognized in the literature on MRP system design.

Alternative planning frameworks have been developed by Bertrand, Wortmann & Wijngaard, 1990b, Bauer, Bowden, Browne, Duggan & Lyons, 1991, see also Browne, Harhen & Shivnan, 1996, and Banerjee, 1997. These frameworks pay more attention to the relationship to production system design. For example, in their Factory Co-ordination module, Bauer, Bowden, Browne, Duggan and Lyons (1991) make a distinction between a production system redesign task and a work flow co-ordination task.

Bertrand, Wortmann and Wijngaard (1990b) recognize the important role of co-ordination within and between production units and the sales department in structuring the planning system. They also consider the consequences for the production system. They define a production unit mainly from a production control point of view. The operations that are to be performed within a production unit belong to the same production phase. They design a suitable overall control structure for the goods flow between these phases. A production unit should be able to reach its (logistical) objectives and to perform its operations independent of other production units as long as material and capacity is available.

---

<sup>1</sup> It is remarkable that the characteristics of the production systems to which the initial publications on MRP refer have much in common with the production systems that are being redesigned if PBC systems are implemented. They both have component production as well as assembly operations.

The production system need not be decomposed according to these units, even though the planning system is. In Wortmann, Muntslag & Timmermans [1997: 169], Muntslag even notes that it would generally be undesirable to create separate production departments for each production phase, i.e. to let the decomposition of the planning system into production units be identical to the decomposition of the production system into production departments. The reason for this incongruence is the fear of a lower utilization of resources. In their design for a planning system structure for goods flow control, Wortmann, Muntslag & Timmermans [1997: 167] present some criteria for determining goods flow control items and production phases. They suggest decoupling the goods flow according to (1) the possibility of reducing uncertainty, (2) the presence of a resource capacity bottleneck, or (3) the product structure.

We conclude that the work of Bertrand, Wortmann, and Wijngaard and the related work of Muntslag take the characteristics of the production system into account when designing a planning system. However, the relationship between the concept of a production unit and the decomposition of the production system is not worked out in detail, and the main focus is still on the production control aspects.

From this literature review, we conclude that the mutual relationship between structuring the production system and the planning system is only partly recognized in literature on the design of planning systems.

#### § 4.1.3 PBC literature on production and planning system design

In PBC literature, there is a strong emphasis on the mutual relationship between structuring the production system and the planning system. Burbidge [1975a: 79-80] gives an example of a plant that used a functional layout for its production system and successfully operated PBC with a cycle (period length) of four weeks. He found that if this firm had redesigned its production system by applying a group layout, a PBC cycle length of one week would have been possible, due to the use of other planning mechanisms for some critical components. This example shows a production system redesign enabling a planning system redesign.

The other direction of the relationship between both system structures is also recognized in this literature. The structuring of a PBC system can make it necessary to modify the production system, using for example the '*Production Flow Analysis technique to identify complex routes and eliminate them by re-routing, re-design, change of method, or buying instead of making*' [ibid. 1975a: 85].

According to Burbidge, the design of a production control system is strongly related to the design of the production system. In his initial work on planning, Burbidge (1962) gives two definitions of production control. In its widest sense, production control is concerned with all factors that affect the flow of materials in production and with the ways in which different material flow systems can be created and controlled. In a more narrow sense, it is only

concerned with the existing production system. The wider definition includes not only system elements such as labour, machines, and capital, but also functions as organisation, production and process planning, design, plant layout, purchasing, sales and forecasting. The production system decomposition affects the complexity of the production control function, and hence the costs of the required co-ordination and the efficiency of the production system.

For the integral design of both systems, Burbidge (1971) proposes using four principles:

1. simplify the material flow system
2. centralize the responsibility for components
3. reduce set-up time
4. reduce throughput time

The first principle results in fewer material handling efforts, improved throughput rates, and simplified control of production progress and transportation activities. The simplification of material flow should not be restricted to the production departments, but also be applied to the flow of material from suppliers and subcontractors, the flow to distributors and clients, and (on a lower scale) to the flow between work centres and at machines (Burbidge [1962: 35]).

The second principle concerns the organization of inventory control, management of stock locations, and their relationship with production control. The responsibility of inventory control includes the safety stock policy. The responsibility of production control includes the safety time policy. If the responsibility for inventory control of components is not centralized, the level of protection for shortages of components will increase as both the supplying department and the consuming department will protect themselves against shortages.

The third principle recognizes the fact that although set-ups are generally required to offer flexibility to the market, the set-up time is non-productive time for the system. Reduction increases flexibility and allows smaller batch sizes, which reduces work in progress and capital investment. However, reduction of set-up time can only be fully achieved if production control and production system are integrally designed.

The last principle relates to the effects of both systems on the throughput time. A good fit between production system and planning system is required to obtain short throughput times. The design objective 'reduction of throughput times' cannot be achieved fully if only one of these systems is the subject of redesign. The portion of slack (waiting time) in the throughput time of products is directly related to the amount of work in process in the production system. Reducing this throughput time therefore reduces the investment in inventory, the number of products that have to be planned and controlled simultaneously, the size and number of stock positions, and so on.

We conclude that in PBC literature, the design of the planning system is not viewed as a process that can be isolated from the design of the production system. The decomposition of the organization into units and the design of the material flow system can help to simplify the

planning system. A good fit between this decomposition and the structure (stages) in the planning system will result in a higher performance and ability to further improve the system.

The design parameters of the planning system will determine the resulting throughput time, but the congruity with the design of the production system determines if these throughput times can be realized. For a basic unicycle period batch control system, the throughput time is determined by both the length of the period between successive order releases (the cycle time P, which equals the offset time) and the definition of the stages in the planning system. Stage definition determines the number of stages as well as the contents of the stages (the operations that have to be performed in each stage). The design of the production system will affect these parameter choices, and conversely, the setting of these parameters will impose changes in the design of the production system.

The next sections will focus on the three design parameters of the basic unicycle PBC system. We will discuss the relationship between each parameter of this planning system and the design of the production system.

## § 4.2 Length of planning period P

An important characteristic of the basic unicycle PBC system is the cyclic nature of the production activities within a stage. At the start of each period, a new amount of work arrives in the cells within the stage, and after a period of length P has elapsed, all work has to be finished. Next period production requirements may be slightly different, depending on differences in the sales program for that period. Notwithstanding these variations, at the end of each period, all assigned work packages within each stage have to be finished in order to remain a synchronized system. The choice of the period length P is therefore an important part in designing a PBC system.

### § 4.2.1 Choice of period length

Burbidge [1979: 208] says on the choice of period length: *‘The choice of programme period is mainly a function of the complexity of the product. ... The problem when choosing the programming and ordering period, is to balance the gains with a short period, such as a reduced investment in work in progress and an increase in the flexibility to follow market changes, against the losses which may be caused by an increase in the number of set-ups.’*

He also presents some guidelines for choosing the period length P:

- there must be enough capacity to complete all the parts/products ordered each period
- it must be possible to complete each batch of parts/products in one period
- effective capacity (which is reduced by set-up activities) has to be acceptably high

These guidelines assume that the production activities that have to be performed during the period are already known when the length of the period has still to be determined. The structure of the production system has therefore been determined, cells have been designed, part families have been defined and allocated to these cells, stages have been defined, and information is available on the approximate size of the batches.

Burbidge first determines the number and contents of the stages and then the period length  $P$ . This sequence is not uniformly applied. In a publication on the implementation of PBC, Zelenovic and Tesic (1988) chose first the 'operating period'  $P$  and for this decision they used information from the bill of materials, production program and the production system itself. The cells were formed afterwards. Note that in their approach, the sequence of the processes that are to be performed in the production system is known when the decision about the period length is taken, but not the division into stages and cells.

The structure of the production system influences the choice of a suitable period length in a PBC system. Burbidge [1975a: 79-80] reports on a production system that had been decomposed into functional departments with a complex interdepartmental material flow. This system had to use a period length of four weeks. An important part of this period length consisted of slack time that was required for co-ordinating these flows. This resulted in a higher period length than the one week period length that was shown to be possible if a cellular decomposition of the production system had been implemented.

A cellular decomposition of the production system makes it sometimes easier to apply overlapping production. This effects a reduction or elimination of micro-waiting times in the process flow of a production batch. To apply overlapping production, necessary conditions are a small distance between the successive machines in the process flow, easily transportation of parts in progress, and machine operators that feel responsible for and are prepared to co-operate in finishing the whole batch as soon as possible. Overlapping production requires a process view, as it tries to reduce the co-ordination losses of subsequent processing steps. In general, such a process view is essential for the success of cellular manufacturing. A cellular production system will therefore be better prepared for applying overlapping production within the cells.

Overlapping production has an important effect on the choice of a period length. The total processing time of the production batch remains constant if overlapping production is applied, so it has no effect on the work load of the system. The make span of the batch, i.e., the time required to finish producing all items of the batch, is substantially reduced, as overlapping production makes it possible to perform multiple production activities in parallel at the same production batch. In § 3.3.6 we already described several aspects of overlapping production. The question remains as to what extent we should use overlapping production and what effect it will have on the period length. In Chapter Five we will answer these questions by doing a mathematical modelling analysis and examine the consequences of applying overlapping production in order to determine a suitable value for the period length.

The choice of the period length has important effects on operational issues relating to the production system. We describe two effects, the *set-up time effect* and the *start/finish effect*.

### *Set-up time effect*

The set-up time effect is mentioned in most literature on PBC (e.g., Burbidge, 1988, New, 1977, Steele, 1998) and we have illustrated it in Figure 4.3. The period length determines the number of production cycles for each product per year. If the demand of product  $h$  per time unit ( $D_h$ ) is equally distributed over the periods, then  $q_h = D_h \cdot P$ ,  $P$  expressed in the same time unit. If  $P$  decreases, the batch size  $q_h = D_h \cdot P$  also decreases, but the process still has to be set up for all products  $h$ , so the total required set-up time per period remains constant. Net capacity therefore decreases, resulting in less slack for this process. We will call this the set-up time effect.

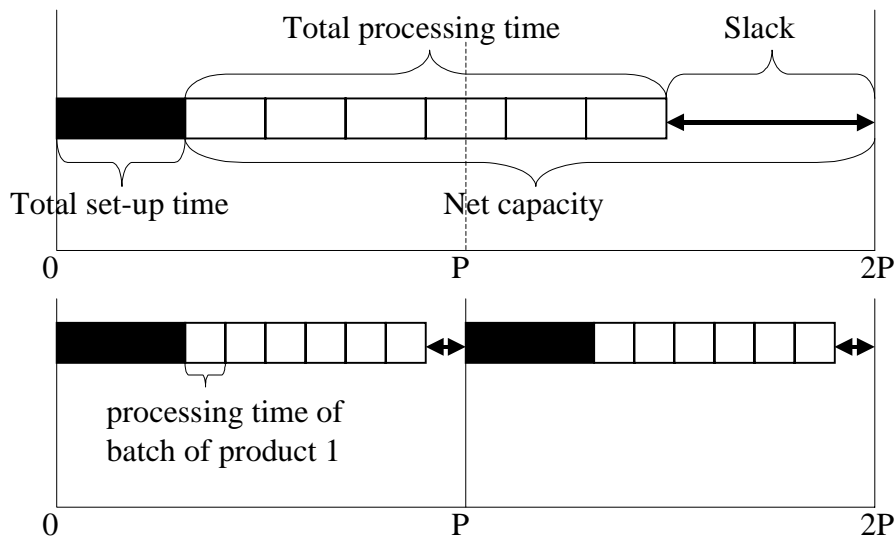

**Figure 4.3** Set-up time effect

### *Start/finish effect*

A related effect is known as the start/finish effect. The cyclic nature of PBC significantly affects the net capacity of intermediate processes in the same stage. Intermediate processes (for example, machine II in Figure 4.4) are either preceded or followed by another process in the same stage. Preceding operations cause a start delay, while subsequent operations cause a finish delay. The net capacity of intermediate processes will decrease if the period length decreases, as long as the precedence relationships between operations remain the same within the period. The time required for the start-up or finish activities depends on  $P$ , as a smaller  $P$  results in smaller batch sizes for these operations. The reduction in  $P$  often exaggerates the reduction in these start and finish times, as they contain time necessary for the transfer of a batch between machines. This transfer time does not depend on the size of the batch. We will call this the start/finish effect and have illustrated it in Figure 4.4.

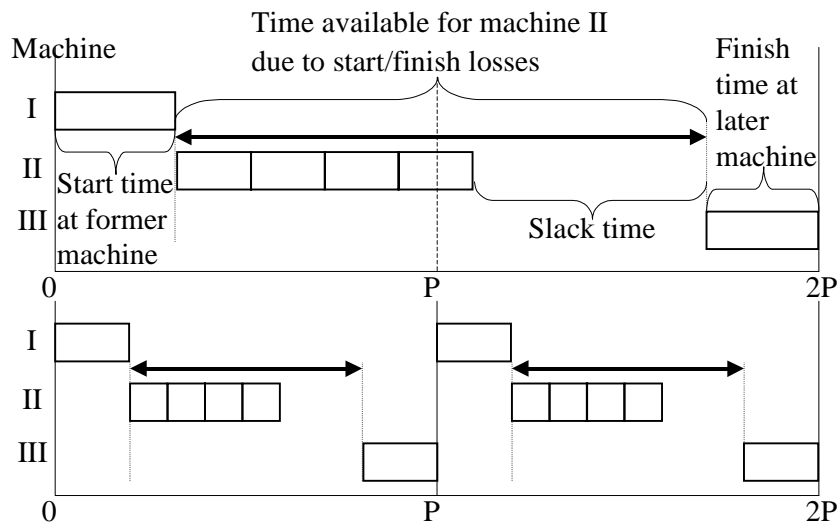

**Figure 4.4 Start/finish effect**

Literature on PBC implementation proposes various period lengths. Burbidge (1962) recommends either a month or a four-week period. New (1977) suggests that cycles of either two or four weeks are the achievable standard in most situations, while in extreme cases, a six-week cycle may be necessary. Burbidge (1975b) reports on a survey of 40 companies, where the period length ranged from 4 working days to 13 working weeks. Most firms used one month or the equivalent number of working weeks or working days as a period length. Zelenovic and Thesic (1988) and Slomp (1993) propose a period length of one or two weeks. The more recent publications of Burbidge (e.g., 1988, 1993, and 1996) generally recommend using at most one-week periods. Process industries (especially the food industry where shelf life is critical) could use periods of one day or one shift.

Literature that evaluates the performance of PBC also experiments with different period lengths. Yang and Jacobs (1992) tested two, three, and four week period lengths. Steele, Berry and Chapman (1995) tested periods of 1 day, 5 days, and 6 weeks. Steele and Malhotra (1997) used 3, 4, 5, 6, and 7 days. Kaku and Krajewski (1995) used a minimum cost search algorithm to determine a suitable period length in their experiments. The integer valued period length that they obtained was 2, 3, 4 or 5 days.

The various period lengths that we have encountered all have one comparable feature: they are expressed in some common time measure, either months, weeks, days, or shifts. Are there any reasons to restrict the length of a period to these time measures? Or is it also appropriate to choose  $7\frac{1}{2}$  shifts of 8 working hours as a period length?

The practical aspects of a suitable period length are an important factor in the design of the planning system. The planning system has to offer synchronization of material transfer between stages, and the way this is guaranteed is by providing transparent work progress within the system. This transparency is only present if all people in the system are aware of the period length and the actual finish time of a period. The transparency is also used in

relations and communication with suppliers and customers. In general, communication with customer and internal sales department can be expected to be easier if a natural time measure is used. Information on the date of usage has to be sent to the supplier. An easy to use period length is often preferred, both by the supplier and the internal material receiving function, as it is easier to remember that new material should arrive (knowledge of deadlines) when a general rule is applied. The same holds true for arranging program meetings with the planning board (same day, same time). The essential prerequisite is that the period length creates a natural rhythm for the production system.

Finally, we want to make the observation that the repeating pattern of production activities that results through the use of a fixed cycle has a positive effect on the learning behaviour of the operators, as long as these workers indeed repeat these activities themselves. The number of working shifts in a period can disturb this learning effect. If the next cycle starts with a totally different work force, this may result in abeyance of these learning effects. An increase or decrease of the period length that facilitates the occurrence of a repeating pattern may result in an enhanced system design as the production system improves.

§ 4.2.2 Trade-offs in the choice of period

Changes in the period length have consequences for several aspects of the design of a production structure and system performance. Figure 4.5 shows us the effect of a reduction of the period length P to P'. We see that both the manufacturing throughput time and the order lead time or forecast horizon (if one produces on forecast) decrease if P decreases. Literature on PBC gives the following additional insights:

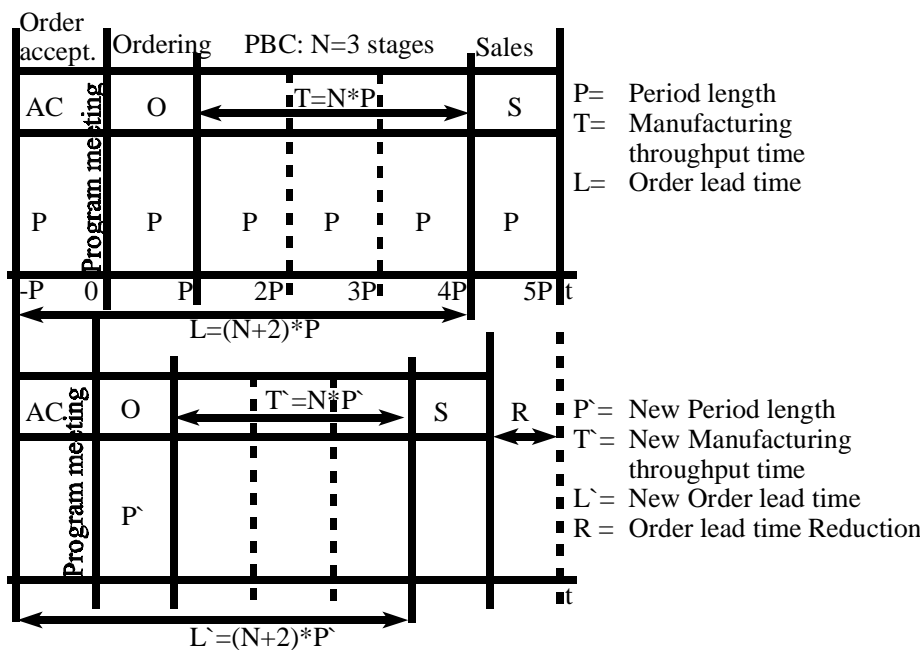

Figure 4.5 Effect of reduction of period length P

New (1977) notes that the shorter the period length, the more flexible the production system will be. Furthermore, the demand forecasts for the sales period become less uncertain, as this sales period is reached earlier in time. It should be noted that the flexibility to which New points is related to the response time to the market if some products are made to stock.

Whybark (1984) emphasizes the positive effects of a shorter period length, and mentions a quicker customer response, a higher potential market share, a higher percentage of orders that can be made strictly to order, and a lower cycle stock. On the other hand, a higher period length will result in higher manufacturing efficiency, fewer set-ups, lower manufacturing costs, and larger purchase quantities. Note that these benefits are strongly related to the design of the production system. Furthermore, a higher period length leads to a higher risk of unbalanced end product stock resulting in an increase of unsaleable stocks and an increase in stockouts for products for which the demand is greater than expected. The latter may result in an increase in the overall safety stock level.

Suresh (1979) notes that reducing the cycle time in PBC is consistent with the objective in MRP systems of reducing the time bucket size and results in greater precision in timing the orders and greater flexibility since firm orders need to be given only for the immediate period.

Yang and Jacobs (1992) found that a higher  $P$  results in a decreasing mean order tardiness, and less variety in order tardiness. Process dependability therefore increases as  $P$  increases. However, this is accompanied by an increase in the work in progress and the various stocks in the system. For this reason, they conclude that increasing the period length does not seem like a good alternative to improving delivery performance.

With respect to the flexibility, we note that both the volume flexibility and the mix flexibility may decrease if the period length is shortened. Volume flexibility may decrease because the ordering period is smaller, which leaves less time for making adaptations to the capacity in the production system. Mix flexibility decreases because of the set-up and start/finish effects, which leave less slack time. However, if we face lumpy demand, the number of set-ups per period may decrease if the period length is shorter, which allows more remaining capacity for production and hence an upward shift in volume flexibility.

A reduction of  $P$  also affects the forecasting effort. Two factors have to be taken into account. Firstly, a reduction of  $P$  results in a smaller sales period for which the demand has to be forecast. Theory on forecasting teaches that a forecast for a smaller period is in general less reliable. A less reliable forecast combined with decreased mix flexibility results in an exaggerated sensitivity of the system to changes in demand. This will have important consequences for the design of the production system.

Secondly, if  $P$  is reduced, the frequency of forecasting increases, since for each program meeting, a forecast for the next sales period has to be produced. This leads to an increase in the work load of the forecasting function within the organization. This increase in work load

is independent of the required increase in forecasting quality due to the first factor that we mentioned. Note that PBC systems that produce on order will not encounter the two forecasting problems mentioned, but the increased sensitivity to changes in demand and the increased effort required of various departments that are involved in co-ordinating the transformation process will also become apparent in these organisations.

Our discussion on the relationship between the production system and period length has demonstrated the importance of determining the period length in the structuring of a basic unicycle period batch control system. Although we have presented several insights into factors that are important when determining a suitable period length, we have not paid any attention to approaches that help to determine a suitable value for the period length. It should be noted that other planning systems, such as MRP and Kanban, also lack such approaches. In Chapter Five we will develop several mathematical models that may be used in order to determine a value for the period length. The effect of period length determination on costs and system performance will also be addressed.

The effect of stage definition on the design of the production system and the possibility of achieving the overall system objectives have to be clarified first. Stage definition consists of determining the number of stages N, which is treated in the next section, and determining the contents of the stages, which is discussed in Section § 4.4.

### § 4.3 Stage definition: number of stages N

The relationship between the number of stages and the structure of the production system is important to examine. Production systems are generally decomposed into several units. The characteristics of these units may vary. A global distinction between various production system characteristics in line production, batch production and jobbing production has been made by Hill (1991). The varying characteristics and the required logistical performance place different demands on the planning system that is used for the planning *within* these units. If the production units each have a different internal structure and local planning system, co-ordination between these production units still has to be performed. This co-ordination concerns not only sequential co-ordination (goods flow, resource flow, information flow) between units, but also simultaneous and latent relationships, as discussed in Chapter Two.

Sequential co-ordination of the goods flow *between* successive units can be performed in several ways. In general, a distinction should be made between push or pull co-ordination mechanisms. Both mechanisms assume that each unit acquires an amount of time from the overall logistical planning system to perform the tasks. This amount of time can be seen as being the maximum lead time that is available to the unit for performing the task. If the planning system uses such a lead time offsetting procedure for the co-ordination of the goods flow between the units, then the resulting planning system structure will be strongly related to

the decomposition of the production system into units. Hence, in these cases the definition of these units will affect the design of the planning system.

PBC uses such a lead time offsetting procedure between *stages*, as we described in Chapter Three. An important facet of the basic unicycle PBC system is that each stage is provided with the same internal lead time. This leads to a synchronization of the material movements between the stages. However, the question remains as to how the departmental structure of the production system, i.e., the units, should be used for the definition of the stages.

This problem of defining the structure of the planning system is not unique for PBC. Other planning systems, such as MRP and Kanban, also have to apply a decomposition of the planning structure. These systems often apply a decomposition that resembles the existing departmental, cell, or work centre structure, without taking notice of the possibility of finding an improved decomposition of the production system that takes account of the interaction between both systems.

PBC literature suggests redesigning the production system using Production Flow Analysis. The resulting decomposition of the production system should be used to determine the structure of the planning system, and more specifically, the number of stages in the planning system. We will examine the contribution made by this procedure in more detail in the next subsection.

### § 4.3.1 Processing stage definition with Production Flow Analysis

Production Flow Analysis (PFA) has been extensively described in Burbidge (1971, 1979, 1989a). The main elements of this procedure are:

factory flow analysis	Divide the production system into departments that can completely process <i>a set of parts</i> . A division <i>according to major differences in processing type</i> will give the simplest possible interdepartmental material flow system
group analysis	Allocate the machines and operators within each department to groups, the parts to families, and finally match the families with the groups into cells. Cells should have an expected work load evenly distributed over the year and high enough to justify combining these machines, operators, and parts into a separate organizational unit
line and tooling analysis	Design layout and material and resource flow system between machines in the cells

A production system that is designed using PFA will probably consist of various cells with a group layout, but this need not always be the case. The assembly department might consist of several production lines, while the component processing department might still be functionally organized as one group that produces all part families.

This description of PFA consists of two elements that we have to study in more detail in order to understand the principles behind the proposed decomposition of the production and planning system:

- the definition of a ‘*set of parts*’
- the assumption that a division *according to major differences in processing type* will give the simplest possible interdepartmental flow system and should therefore be applied when decomposing the production system.

#### *Decomposing the production system according to a ‘set of parts’*

How the decomposition of the production system is carried out will depend on the definition of a ‘set of parts’. The definition of the set of parts therefore controls the decomposition of the production system. However, it is not obvious how the set of parts should be defined. We give three examples:

If the final products are divided into several families and each family is considered a ‘*set of parts*’, we will obtain a vertical decomposition of the production system, i.e., each department will completely process a family of final products. Complete processing means that all operations that are required for the products are performed in one department, for example, from raw material processing to assembly.

Alternatively, if we define all hydraulic components as one ‘*set of parts*’ and all electronic components as another ‘*set of parts*’, we will obtain a totally different decomposition of the production system. That type of decomposition is oriented towards the production of modules.

We can also define the ‘*set of parts*’ in terms of the output of a processing stage. A production system generally consists of various processing stages, defined according to the main processes that each provides and the sequence in which they are required. The differences between these main processes may impose specific requirements on the working environment, material handling equipment, climate, and so on. For example, in metal ware production we can make a distinction between raw material processing, components processing, sheet metal production, welding, surfacing, painting, subassembly, assembly, and so on. If we define the ‘*set of parts*’ according to the processing stages that are present in the production system, we will obtain a horizontal (functional) decomposition of the production system into departments identical to the processing stages. It should be noted that a functional decomposition of the system into processing stage departments does not mean that the cells resulting from group analysis will be functionally organized as well.

#### *The use of processing stages in production system decomposition*

The second element we want to examine is the assumption that the simplest possible *interdepartmental* material flow system will come about if processing stages are used to define the departments. It is well known from literature that the complexity of material flow systems is influenced by the layout of the production system. A line layout has standardized

the flow of material on the line and attention can be focussed on the flow of material to the line and the flow of products from the line. For functional layouts, we have to distinguish between systems with different and bi-directional flow patterns between the functional units, which will result in a complex material flow system, and systems with uni-directional flows between the functional departments. The latter situation results in a less complex material flow system. It can be interpreted as a flow shop, where the time required in each station (functional department) varies per job, but the flow between the stations is equal for all jobs.

If the boundaries of processing stages are used to define the departments, we will obtain a flow shop like functional decomposition of the production system, as defining processing stages involves sequencing the main processes in the product routings. The flow that departments face is uni-directional (no back flow) and the number of different flows from a department to other departments is restricted to the number of downstream departments.

We now return to the issue of the validity of the assumption that the simplest possible *interdepartmental* material flow system will come about if processing stages are used to define the departments. We conclude that a decomposition of the production system into departments according to processing stages may indeed result in an improved flow between the departments if compared with a traditional functional organized production system. The latter apply a much higher degree of functionalisation, resulting in far more departments with more complex routings between them. However, a processing stage definition is only a first step towards a simplification of the interdepartmental material flow, and will surely not result in the simplest possible system.

The simplest possible *interdepartmental* material flow system will come about if we have a production system where each department completely makes a family of products. In such a case, there will not be any material flow between the departments at all, which makes the required planning system quite easy to design. However, such a decomposition will probably result in other inefficiencies in the production system: for example, increased training costs for operators, low utilization of machines, and so on. Hence, a trade-off between efficiency of both the production system and the planning system has to be made.

#### *Alternative stage definitions in Production Flow Analysis*

The decomposition of the production system into processing stages is not a simple matter, but requires an explicit decision. Burbidge [1993: 548] mentions that '*a problem with GT has been in the choice of processing "stages". In general, we have tended to accept the existing stages found in traditional factories, which are normally bounded by stores*'. In [1962: 293] he had already stated that '*for simplicity, this division is normally made on some arbitrary basis*'. These quotations make it clear that it is not necessary to define the stages according to the major type of process that is applied. In fact, in his 1993 publication, Burbidge discusses several situations where he explicitly deviates from this type of division. These deviations are initiated by the design of the planning system structure. However, they do not originate from

the PFA method itself, although factory flow analysis strives to combine several subsequent stages into departments in order to further simplify the material flow system.

New (1977) sees the division of the material flow system as a separation of the factory into 'incompatible' departments. The next step of PFA, group analysis, results in combining facilities and parts of these departments into cells. When this group analysis has been completed for all departments, he expects it may further be possible to combine cells with common component flows that occur in different departments. This would create a situation with sections of one cell in physically different locations, where the cell is treated as a single unit for planning purposes (New [1977: 228]), while normally a cell only exists within one processing stage (ibid. [1977: 221]). Burbidge (1971) notes that incompatibility is partly a function of the choice of machinery, and can often be overcome by investments in equipment, facilities, foundations, control, or other things that enable a combining of these processes. Hence, PFA may also suggest separating a process according to an economic perspective.

The treatment of intermediate subcontracted operations, and of auxiliary and service processes causes another problem in production system decomposition. Subcontracting can be treated as a separate stage, but this may cause a back flow. These operations could also be eliminated through replanning the process routes. The specific co-ordination requirements that originate from such a production system design were discussed in Chapter Two.

We will examine the consequences of the appropriate decomposition of the production system for the decision about how to decompose the PBC system into stages. These decisions can be distinguished.

#### § 4.3.2 Decomposition of the Period Batch Control system into stages

Steele (1998) notes that PBC matches the stage-like structure of the cellular production system and creates a phased flow of production lots through these stages. In fact, PBC is designed for the management of stages of production corresponding to periods of time. He concludes that stage definition is nevertheless not well understood.

Publications on PBC do not pay much attention to the exact definition of stages in PBC, as noted in § 3.3.3. The main distinction is between an assembly stage and ordering, e.g. the procurement of the required components. A division of the ordering stage is not given in advance. There must simply be enough time in the ordering schedule to perform all required processes between ordering and completion of the parts. For some production situations, this may include material acquisition, or product design, while others will have raw material in stock or do not need to redesign the products.

If items pass through a number of different departments, Burbidge (1962) divides the ordering stage into subdivisions. Each subdivision receives a target date on which all work on the batch

should be completed. This division is made on an arbitrary basis, as we have noted before.<sup>2</sup> If we analyse the stage definition approach of Burbidge in later publications (e.g., 1975a, 1989a, 1989b, 1993), we conclude that there are inconsistencies in his descriptions of the stages in the ordering schedule, mainly with respect to the timing of activities (the parallelogram) and the way he treats (or ignores) parallel processes.

We conclude that the way Burbidge determines stages does not provide us sufficient help in making this important decision in PBC system design. We have to further explicate factors that should be considered in this decision process. We assume that the allocation of operations to cells has been performed, i.e. it is known *where* the operations are being performed. Stage definition determines *when* these operations are being performed.

#### *A framework for determining the stage decomposition in PBC*

We propose a framework for determining the decomposition of the PBC system into stages. The framework identifies the various choices that have to be made in order to provide the planning system with an adequate structure. It should be noted that the structure of the planning system is equivalent to the number of stages in the PBC system.

Before identifying the stages, the system objectives should be formulated and prioritized in a way such that they can be used as guidance in designing the planning system<sup>3</sup>. To make an integral design for the production and planning system, we need to know *what*, *when* and *where* to deliver (see Figure 4.2). After these decisions, we should determine specific system objectives in terms of:

- speed (lead time)
- dependability (tardiness)
- flexibility
- quality
- costs

According to the weighting of these system goals, a trade-off should be made with respect to the impact that these goals may have on stage definition. From a lead time perspective, it may be wise to combine several operations into a stage, but not from a dependability perspective.

---

<sup>2</sup> The ideas for the subdivision stem mainly from the operation of the related standard batch control system (Burbidge, 1960). In this system, he introduces the decomposition of the production system into *sections*. Sections receive order lists with all item orders having common due dates. A section order may be broken up into several *stage sheets* if different groups of parts that are needed for the same batch of products are required at different due dates. The division of the production system into sections and stages in the standard batch control system is strongly related to the actual product structures as well as the existing organisational division.

<sup>3</sup> We would like to see these objectives used also in defining the structure of the production system, but a decision to do this is often driven by the differences in processes, as we have shown in the former subsection.

As the weighting and priority given to the five system objectives will vary for each production situation, we cannot conjecture in general about stage definition. However, if we have system objectives in a specific situation that are ranked according to priority, we are able to identify relevant aspects of the production system or planning system that will influence these objectives and to identify the impact of stage definition on these objectives.

The desired number of stages in a PBC system depends on characteristics of both the production system and the mix of system objectives that the planning system aims at to achieve. Note that each stage in the basic unicycle PBC system obtains the same amount of time (one period of length  $P$ ) in order to complete the processing steps of this stage. Therefore, the length of the period may influence these characteristics as well as the possibility of achieving the objectives. For example, if a small throughput time (speed) is more important than quality or flexibility, processing steps may be combined into one stage. Alternatively, the shorter throughput time may be obtained through a smaller period length and separate stages, as we discuss further in Chapter Six.

In our framework for planning stage definition, two factors stand out:

- there might be a significant change in *uncertainty* between two processing steps, which may indicate a useful position of a stage boundary (production system related).
- there might be a significant change in *required accurateness of control* between two processing steps, which may indicate a useful position of a stage boundary (planning system related).

Table 4.1 shows how these factors can be applied to the various objectives mentioned before. The examples give an impression of the influence of stage decoupling on system objectives.

With respect to the change in uncertainty, we need to consider that this uncertainty may be inherent to either the conversion process itself or the co-ordination needed between the two successive processing steps. For these types of uncertainty, Susman (1976) introduced respectively the terms *conversion uncertainty* and *boundary transaction uncertainty*. In Chapter Eight, we will discuss these types of uncertainty further.

The accurateness of control that is required for successive processing steps may vary. The weight that is given to a specific system objective influences the attention that should be paid to this control problem. We can already identify a change in the required accurateness of control between two successive processing steps without specific knowledge of the weight of the related system objective. However, the magnitude of this change cannot be determined without knowledge about the importance of achieving this objective. If the achievement of a system objective prescribes different control approaches for successive processing steps, we expect this will be more difficult to accomplish within the same stage than between stages. This explains why we have indicated this a separate factor.

	Production system: change in <i>uncertainty</i>	Planning system: change in <i>accurateness of control</i>
Speed	If the speed of a preceding processing step varies, for example, yield uncertainty in wafer processes, stage decoupling functions as a buffer that may lead to an increase of the output (cycle time) of the whole process.	If a processing step is to be performed at a bottleneck, stage decoupling may help to improve the utilization of the bottleneck, because of an improved control of the sequence of release of work to the bottleneck, and of the availability of material, resources, and information.
Dependability	If the addition of a processing step to a stage results in a substantial increase in uncertainty of whether the work will be finished within a period length P, stage decoupling can be considered.	If a processing step requires the availability of several incoming flows, e.g., an assembly operation, stage decoupling can be considered.
Flexibility	If the addition of a processing step to a stage results in a substantial increase in uncertainty about whether the intermediate items can be used effectively, decoupling of the stage can be considered. See, for example, the customer order decoupling point.	If the next operation requires a different control approach, because the required flexibility has to be found externally instead of within the system, stage decoupling can be considered in order to obtain time to prepare this decision.
Quality	If there is uncertainty with respect to the exact specifications of a processing step (e.g., art work, design processes), stage decoupling allows an improved control of the final quality.	If a processing step requires a different quality control approach, e.g., presence of an external quality inspector, stage decoupling can be considered in order to buffer the remaining operations from this dependency.
Cost	If the cost of a processing step depends on the availability of a specific grade or dimension of the input material, stage decoupling will allow the operators more choice when they select the required material, leading to lower cost.	If a processing step requires expensive components from an outside supplier, stage decoupling before this step can help to improve the control over working capital increases and lower the total cost.

**Table 4.1** Examples of factors that influence PBC stage definition

*Production system decomposition and co-ordination requirements*

The type of work that is controlled by PBC will generate different co-ordination requirements, as discussed in Chapter Two. This influences the structure of the planning system. In general, assembly operations should be distinguished from component processing operations, as they generate sequential relationships with more preceding operations. Furthermore, the required accurateness of control is higher, as all parts have to be available at the start of the assembly. Therefore, a natural division between the stages will result, as this guarantees that all parts have been completed or arrived before assembly starts.

Conversely, separation of component processing and finishing in subsequent stages is not obvious from a planning point of view. Although the processes are incompatible, making transportation of the material necessary, this need not result in a separation of the two processes into different planning stages. For example, the finishing operation can be organized as a service centre, or can organizationally be allocated to a component processing cell without physically combining both processes at one location. In both situations, the structure of the planning system does not change, although the processes are incompatible. Reasons other than these co-ordination requirements may still lead to the separation of both processes in subsequent stages.

From this, we conclude that the definition of stages in a PBC planning system does have to take on some of the characteristics and decomposition of the production system, but that there are also factors from the planning system that have to be taken into account.

The number of ‘unavoidable processing stages’ in the production system cannot be used directly for a useful definition of stages in a PBC system, as is done by Burbidge. The main reason for this is that the number of processing stages does not give enough insight into the complexity of the co-ordination problem between and within the stages, no matter whether this complexity is caused by conversion uncertainty, boundary transaction uncertainty, or the required accurateness of control. Planning systems should handle this co-ordination complexity in an adequate way and need therefore to be structured such that this co-ordination can be performed. Our framework provides a systematic way of setting the number of stages.

**§ 4.4 Stage definition: allocation of operations to stages**

One of the important decisions after determining the *number* of stages  $N$  and period length  $P$  in a PBC system concerns the allocation of operations to the stages, i.e. the *contents* of the various stages. Our framework indicates that the allocation of operations to stages influences the start/finish losses, dependability, bottleneck utilization, subcontracting co-ordination problems, and investment in working capital. Other effects, such as the set-up-time effect, are not affected by the allocation of operations. They only depend on the number of stages  $N$  or on the period length  $P$ .

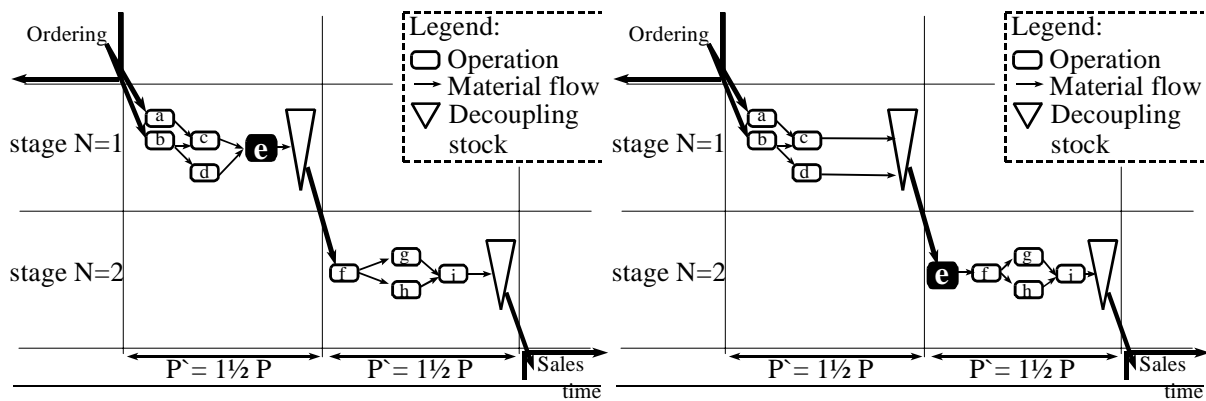

Figure 4.6 Original stage allocation

Figure 4.7 Alternative stage allocation

We illustrate the importance of stage contents determination in Figure 4.7, which shows an alternative allocation of operations to stages compared with Figure 4.6. The reallocation of operations affects the workload distribution of resources over the period. The two operations  $e$  and  $f$  were allocated to different stages, but are now allocated to the same stage. Hence, in Figure 4.7, operation  $f$  cannot start at the beginning of a period, which was possible when both operations were allocated to different stages. This has consequences both for the earliest starting time of *following* operations in stage 2 and for the latest finishing times of the *preceding* operations in stage 1. It therefore affects the workload distribution of the resources that perform these operations.

#### § 4.4.1 The relationship between cells and stages

We have criticized the use of a technologically based division of the production system into processing stages as a design criterion for the structure of the PBC system. However, such a division makes the allocation of operations to the stages quite easy. The framework that we have proposed should help to determine suitable stage decoupling points in a PBC system. A change in the uncertainty between two successive processing steps may be a valid reason for introducing a stage decoupling point. This raises the question of the relationship between the cellular decomposition of the production system and the occurrence of a change in uncertainty between successive processing steps when determining the contents of stages for PBC. The framework allows for stage contents that involve the presence of multiple cells delivering to each other within the same stage, as long as there is no substantial change in uncertainty or required accurateness of control.

PBC does not provide sequential co-ordination between cells within a stage. Another part of the planning system has to cope with the remaining co-ordination within and between cells in a stage, see e.g., Burbidge (1988). The length of the period and the number of cells in a stage will influence the complexity of the remaining co-ordination between cells in a stage. We will discuss this remaining co-ordination in Chapter Eight, but firstly we will amplify upon the relationship between cells and stages in more detail.

We want to determine how desirable it is to define stage contents as being not identical to the contents (operations) of one cell. If the contents of both are identical, we have stage boundaries that exactly overlap with cell boundaries. All operations for a future period of demand that are performed within the same time bucket (the stage) are performed within the same organizational unit (the cell). The benefits of such an allocation are mainly that there will be simplified and transparent co-ordination between the cells. Will these benefits still be present if we apply a different allocation of operations to the stages? We will discuss this problem in the next two subsections according to the following questions:

- Should we design stages with operations performed in various cells?
- Should we design cells with operations performed in various stages?

#### § 4.4.2 Stages with operations performed in various cells

Situations with various cells within a stage are depicted in Figure 4.8. Cells X1, X2, X3, X4, and Y are all active within the same stage. Cell X1 is sequentially related to cells X2 and X3. The latter two are sequentially related to cell X4. Cells X2 and X3 are simultaneously related within the same stage. All cells X1, X2, X3, and X4 are simultaneously related to cell Y.

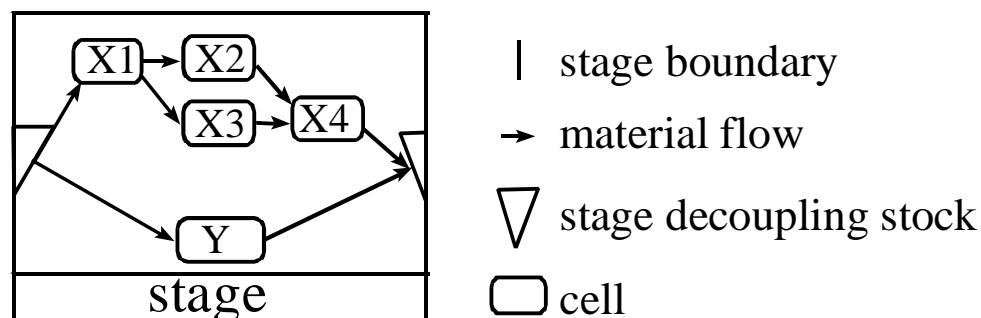

**Figure 4.8 Operations involving various cells within the same stage**

#### *Simultaneously related cells within a stage*

Cells that are only simultaneously related within the same stage can produce independently. Their relationship does not constrain the production activities, but it may provide useful information on priorities, as they both produce for the same sales period demand.

There is no objection to allocating simultaneously related cells to the same stage. Allocating them to different stages might increase the number of stages and hence the throughput time, without any benefit with respect to the required co-ordination effort.

*Sequentially related cells within a stage*

Sequentially related cells within a stage cause start/finish effects, which may reduce the performance of the system. The operations of the sequentially related cells can be combined within a new cell, which would make it easier to co-ordinate the relationships between the successive operations and might diminish the negative impact of the start/finish effect.

However, there are reasons for not preferring such a redesign. These reasons are derived from the three categories that were described in detail in Section § 4.3.1: economic reasons, group effectiveness<sup>4</sup>, and environmental issues.

Economic	utilization, material efficiency, specialization
Group effectiveness	group size and synergy, productive multi-functionality, variety of education level
Environmental	locative constraints of processes (e.g., foundation, noise, dust), incompatibility of processes

**Table 4.2 Reasons for allowing various cells within the same stage**

Economic and environmental reasons will be prevalent if some of the operations in a cell cannot be allocated towards other cells that also require these processing steps. The sequential relationships between cells can be divided into linear, convergent and divergent relationships.

With a convergent or divergent relationship, various cells within the stage all have a sequential relationship with one particular cell in the stage. This isolated cell could have been duplicated to create two or more simultaneously related cells. However, this solution has a cost in terms of the economic or environmental reasons mentioned. Avoiding duplication of resources, material inefficiencies, cost of investing in the required environmental conditions, and reduction of specialization level may be more important than organizational or logistical reasons that would prefer a combination of these operations in one cell.

For a linear structure, the economic reason is not valid. The other reasons for separating the flow within a stage, such as environmental issues and social effectiveness of the work group may still hold. Work groups might benefit from separation into two groups of workers because of an unproductive group size or a huge difference in culture or educational level. The factors that we discussed do not provide a reason for a stage decoupling in the planning system (no change in either uncertainty or required accurateness of control). It is the quality of the decomposition of the production system into cells that might improve. Therefore, such a decomposition of the production system does not make it necessary to separate its processing steps into different planning stages.

<sup>4</sup> Defined by Hackman (1982) in his normative model of group effectiveness.

## § 4.4.3 Cells with operations performed within various stages

A distinction should be made between cells with boundaries that exceed the stage boundaries (cell X in Figure 4.9), and cells that are simultaneously active in various stages because the processing steps can be performed in parallel (cells Y and Z in Figure 4.9). In basic unicycle PBC systems, the situation of cell X cannot occur, as the cycle time for cell X is smaller than the offset time. However, the situation of cell X can be viewed as a special case of cell Z that is simultaneously active in various stages. If we allocate several of the operations of cell X to the first stage and other operations to the next stage, we will still be operating a basic unicycle PBC system.

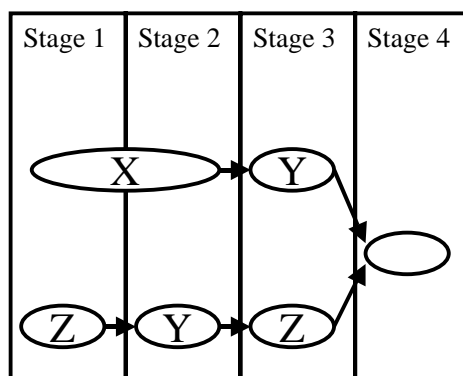

**Figure 4.9** Cells with operations performed within various stages

*Cells that are simultaneously active in various stages*

Cells X, Y and Z are simultaneously active in various stages. Cell Y performs the *same type of operations involving different components* that both have to be worked into the same product. Cells X and Z perform *different types of operations* in subsequent production phases involving the *same components* of the same product. Cell Z faces a back flow between stages.

Suppose we assume that cells have to perform operations for a specific product within one single stage, as described in literature on PBC (e.g., Burbidge [1993: 544], [1996: 215]). We would then have to avoid cell X, Y, Z situations, and to redesign product routings in order to avoid back flows. This would lead to a reallocation of the operations carried out in a cell to an earlier stage. The operations carried out in cell Y in stage 3 would be reallocated to stage 2. However, performing all operations within the earliest stage in which a cell is active would lead to temporally unused stock during the next period. The reduction in work in progress is a strong argument for allowing cells of type Y to become simultaneously active in various stages.

Cells of type X may face the situation that the sequence of operations that have to be performed within the cell takes more time than available within one stage. If all the operations

of this cell were allocated to the same stage, this would require high co-ordination costs (for overlapping production), overtime costs, or result in a low dependability. The cell X situation cannot be used if a single operation takes more time than available within a stage. Dividing such an operation over two stages will result in the periodic release of an amount of work load that exceeds the time available within a period. The required capacity for each operation that arises in both stages in the process routing of cell X has to be smaller than half the period length.

Another argument for preferring cells to be simultaneously active in various stages is related to the *effect of cell work load fluctuation over the periods*. It may be valid for all three types of cells (X, Y, and Z) as long as they partly use the same type of capacity (machine or labour) in both stages. This will be shown using some elementary mathematics.

The work load of a cell depends on the number of products it has to make within a period. Suppose the cell produces two different part types A and B that are both worked into a single end product. Each end product requires  $k_a$  parts A and  $k_b$  parts B (the  $k$ 's are explosion factors). Every period, the work load of the cell consists of a batch of parts A and a batch of parts B. The size of the batches of parts A and B that are produced within a period in the cell are simply a multiple of the explosion factor and the demand for this end product during the sales period for which they are made.

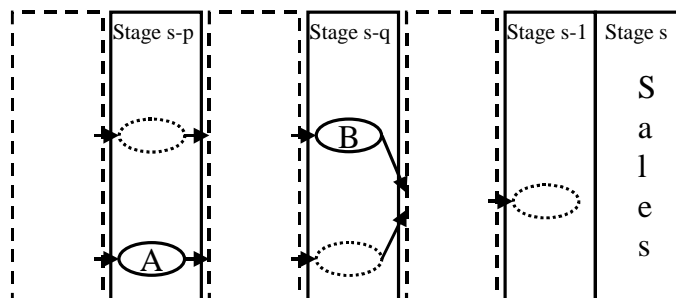

- Ⓐ Cell producing part A for the end product sales in period  $s$
- Ⓑ Same cell producing part B for the end product sales in period  $s$
- ⋯ Other cell

**Figure 4.10** Work load distribution if cells are simultaneously active in various stages

Figure 4.10 shows an example where parts A are produced  $p$  periods ahead and parts B only  $q$  periods ( $p \geq q$ ) before they are delivered to a customer. The parts that are produced in the cell during one period  $t$  are therefore possibly intended for different sales period demands: part A for sales period  $t+p$ , part B for sales period  $t+q$ . The work load of the cell depends on the amounts of the end product demanded during these two periods.

Let  $D_s$  be the demand for the end product in sales period  $s$ . We will assume that there is no trend, seasonal or otherwise, influencing the demand per period. However, demand may fluctuate according to a stochastic process. We will assume  $D_s$  to be independent of  $s$  and identically distributed throughout all sales periods with mean and variance  $(\mu_D, \sigma_D^2)$ . Hence,  $D_s$  i.i.d.  $\approx (\mu_D, \sigma_D^2)$ .

The demand for parts A in period  $t$ ,  $X_{A,t}$  is a linear transformation of the demand for the end item in period  $t+p$ ,  $k_a \cdot D_{t+p}$ , and hence is independent and identically distributed with mean and variance  $(k_a \cdot \mu_D, k_a^2 \cdot \sigma_D^2)$ . Demand for  $X_{B,t} = k_b \cdot D_{t+q}$  i.i.d.  $\approx (k_b \cdot \mu_D, k_b^2 \cdot \sigma_D^2)$ .

In order to determine the distribution of the total work load for this resource in the cell in period  $t$ , we have to find the distribution of the sum of these two random variables

$$X_t = X_{A,t} + X_{B,t} = k_a \cdot D_{t+p} + k_b \cdot D_{t+q}$$

The mean of this distribution is the sum of both means:  $k_a \cdot \mu_D + k_b \cdot \mu_D = (k_a + k_b) \cdot \mu_D$

The variance of this distribution consists of the sum of the two variances and the covariance:

$$\text{Var}(X_t) = \text{Var}(k_a \cdot D_{t+p} + k_b \cdot D_{t+q}) = k_a^2 \cdot \sigma_D^2 + k_b^2 \cdot \sigma_D^2 + 2 k_a k_b \cdot \text{Cov}(D_{t+p}, D_{t+q})$$

If  $p \neq q$ , the independence of  $D_{t+p}$  and  $D_{t+q}$  causes  $\text{Cov}(D_{t+p}, D_{t+q}) = 0$ , hence:

$$\text{if } p \neq q, \text{Var}(X_t) = \text{Var}(k_a \cdot D_{t+p} + k_b \cdot D_{t+q}) = (k_a^2 + k_b^2) \cdot \sigma_D^2$$

However, if  $p=q$ , we have  $\text{Cov}(D_{t+p}, D_{t+p}) = \text{Var}(D_{t+p})$  and hence:

$$\text{if } p=q: \text{Var}(X_t) = \text{Var}(k_a \cdot D_{t+p} + k_b \cdot D_{t+p}) = (k_a^2 + k_b^2 + 2 k_a k_b) \cdot \sigma_D^2$$

From this analysis we conclude that if a cell is simultaneously active within various stages ( $p \neq q$ ) in respect of the same product, the variance of the work load will be  $2 k_a k_b \sigma_D^2$  smaller than if the cell performs all operations for this product within the same stage. The mean work load is not influenced by this allocation decision. To sum up, if demand between the periods is uncorrelated, cells are more flexible if they are simultaneously active in various stages.<sup>5</sup>

We have seen that there are two reasons for cells to become simultaneously active in various stages: lower work in progress and improved flexibility. However, there are also reasons for not allowing cells to be simultaneously active in several stages. The reasons that we will discuss are:

- 1 reduced standardization of period production requirements
- 2 unstable sequencing policy within cells
- 3 increased number of sequential relationships with other cells

<sup>5</sup> The same type of argument can be used for cells that obtain their work load not from just one end product, but if the work load originates from several products. The flexibility of these cells and the system as a whole increases due to the independence of end item demand. At the same time, we then incur a higher number of set-ups per period, which may again decrease the flexibility.

re. 1 If a cell produces simultaneously for different sales periods of end product demand, the originating period of particular production requirements will be less obvious, making the system less transparent. If all production activities carried out within a period have a direct relationship to the number of end products demanded some periods later, the number of parts that have to be produced in a period is easy to calculate and discrepancies with the actual production quantities in the period are quickly detected. This makes capacity planning easier.

re. 2 If there is a single end product which creates production requirements for several parts in the cell, the sequencing policy within the cell will be less stable. If all production activities are directly related to one sales period, the optimal sequence for minimizing the make span within the cell will remain constant over the periods, in spite of the fluctuating demand over the periods. If the production activities are related to two distinct sales periods, the optimal sequence for minimizing the make span will change when demand varies. This means that the transparency of the capacity planning of the cell diminishes if cells become simultaneously active in various stages. The efforts of the cell scheduler should not then be restricted to capacity alterations (overtime, hiring) or preparing overlapping production, but should be extended to re-sequencing. It is usually difficult to find an optimal solution for these re-sequencing problems. Where there are various end products, re-sequencing is almost always necessary if optimal make span performance is to be obtained.

re. 3 Another disadvantage of the cell being active in separate stages is that the cell can obtain a lot of sequential relationships with other cells within a stage, either as a consuming or a supplying cell. Co-ordinating these relationships can become rather complex if the number of relationships increases. If the cell produces parts for temporally unused stock during the next stage or stages, a kind of slack is added, making it unnecessary to formally co-ordinate the cells that consume these parts. This allows the cell to concentrate on the co-ordination with the cells that use the output directly during the next period.

These factors may be important, but do not justify the preference in PBC literature to allocating all operations that have to be performed within a cell to the same stage. To summarize, the main disadvantages of such an allocation are:

- increase in work in progress and holding costs, as this allocation does not make a distinction between operations that require further processing in the next stage and operations that will have to wait a complete period before they will proceed
- increase in overtime costs or co-ordination costs (extra transfer batches), as this allocation does not take into account the total time required for the sequence of operations that has to be completed within a period
- decrease in flexibility, as this allocation is more sensitive to variations in the work load
- increase of start/finish losses for bottleneck processes in a cell, as this allocation does not take into account specific loading problems that arise due to the periodicity of the system

We conclude that in general it is neither necessary nor desirable to allocate all operations that are to be performed in the same cell to the same stage.

#### § 4.4.4 Relevant factors for allocation of operations to stages

The allocation of operations to *cells* determines *where* the operations are being performed. The allocation of operations to *stages* determines *when* the operations are performed.

The framework given in Section § 4.3.2 provides support for the stage allocation decision. The system objectives are speed, dependability, flexibility, quality, and cost. It can be more or less easy to identify changes in either uncertainty or required accurateness of control with respect to these objectives. Changes with respect to quality and flexibility are often more easily identifiable as reasons for allocating successive operations to different stages than changes with respect to the other three objectives. The latter objectives concern the time/cost trade-off. In a basic unicycle PBC system, speed is determined by the product of N and P. Therefore, given N and P, the allocation of operations to stages will not influence the speed objective.

The decision to allocate successive operations to a (possibly different) stage based on the time/cost related objectives is strongly influenced by the length of period that has been decided on. In Appendix B, we will demonstrate this trade-off in a mathematical model that supports the allocation of operations to stages. This model determines an appropriate allocation of operations to stages, given a period length P and a number of stages N. We will discuss the principles that we apply in this modelling approach.

Costs are influenced by the timing of increase in working capital. Operations allocated to an earlier stage than N cause the required input material to be present on the working capital list for a longer time. Another factor influencing the increase in working capital is the type of operation. Operations differ in the amount and costs of the required inputs and processing time. Hence, by allocating operations to stages, we control when the working capital will increase. The lowest cost solution would be to allocate all operations to the final stage N.

Dependability is related to the time aspect of the performance. It is affected by the possibility of finishing the operations in each stage within one period. If there were no precedence relationships between operations, there would be no need for sequential co-ordination between cells, because all operations could be performed independently. However, in general, precedence relationships are likely to appear between operations. There are three factors that influence the dependability of a product:

First, if successive operations that belong to different cells are allocated to the same stage, we face an increase in uncertainty due to the *organizational impact* of this decision, as we have discussed in former subsections. The complexity of co-ordination increases, and in order to avoid a low dependability we may insert some slack time. This can be accomplished by requiring a minimal time delay between operations that belong to different cells.

The second factor will be called the *longest-path orientation*. The allocation of operations to stages might lead to sequentially dependent operations in cells within a stage. The time required for completing a path of sequentially dependent operations may exceed the available time within a stage. This causes overtime work and tardiness, and hence a low dependability<sup>6</sup>. The likelihood of low dependability increases if allocating operations to stages generates longer paths of subsequent operations. Overlapping production can only partially solve this problem. The occurrence of such long paths within a stage reduces the possibility of developing stable standard sequences/schedules in the cells, which helps to achieve the benefits of PBC. Hence, a suitable allocation of operations to stages is one that allows enough slack time per stage to cope with the long paths caused by sequentially dependent operations within the stage.

Finally, dependability is also influenced by the timing of work load arrival at the bottleneck. This factor will be denoted as a *bottleneck orientation*. We can regulate the loading of a bottleneck with the allocation of operations to the stages. For example, if a bottleneck receives too much work that can only be performed during the second part of a period, a redistribution of preceding operations to an earlier stage may solve these problems. Note that the precedence structure between operations that have to be performed in the same period changes due to this redistribution, but the product structure is not altered. We have illustrated this in Figure 4.6. The machine that performs operation  $e$  first had to wait until all preceding operations ( $a, b, c, d$ ) were finished. In the alternative allocation shown in Figure 4.7, these preceding operations were completed within the preceding stage. At the start of a new period, the machine can immediately begin to process operation  $e$ , although the precedence structure of the product has not changed.

We want to stress that there is no need to strive for an equal distribution of work load over the stages, as is useful in the related problem of assembly line balancing. The differences between these problems make it useless to search for an equal distribution of work between the stages. Stage allocation influences the timing of the operations, not the total work load or utilization of the resources within the production system. It affects due date performance (dependability), speed of a specific product, and costs of the system. The allocation may result in an amount of overtime required to finish the work. The total number of working hours remains unchanged.

The above mentioned factors are demonstrated in a mathematical model in Appendix B. The mixed integer programming model consists of a longest-path orientation which can be extended with a bottleneck orientation. This supports the stage allocation decision.

---

<sup>6</sup> Note that the length of these paths also influences the volume and mix flexibility of the system.

## § 4.4.5 Reconsidering the relationship between cells and stages

Literature on PBC stage design does not pay much attention to the stage allocation discussion. It assumes that cell boundaries are identical to stage boundaries. The negative consequences of such an allocation are usually ignored. In our opinion, the main reason for this lack of attention is the prevailing view on PBC as an intermittent production line without branches (see Figure 4.11).

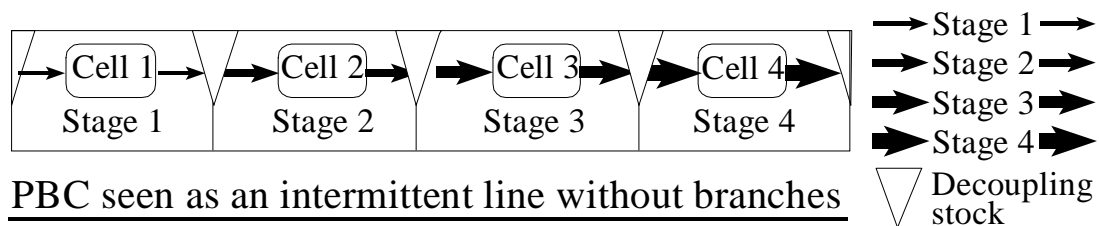
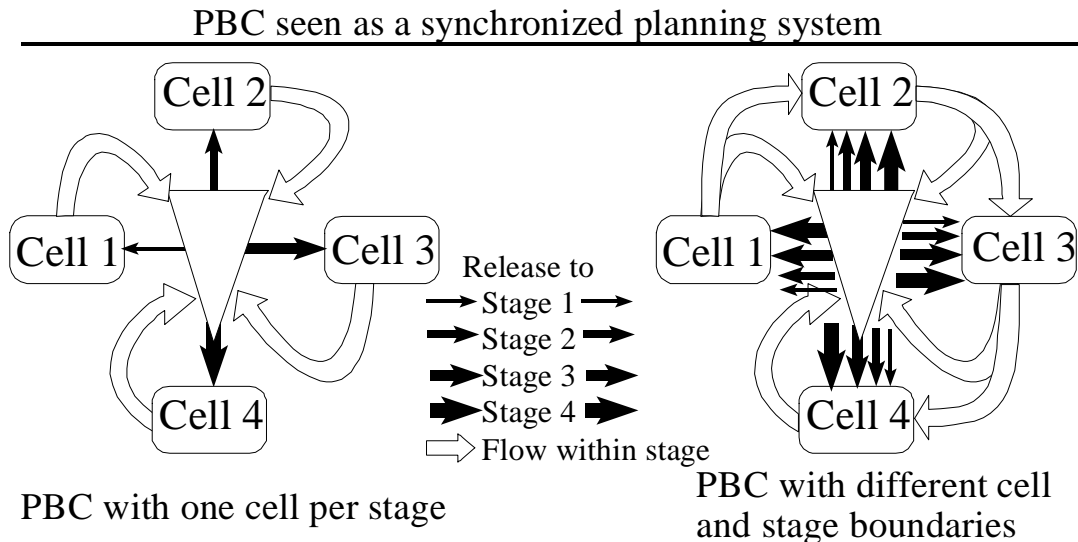

**Figure 4.11 Traditional perspective on PBC synchronization**

In Chapter Three, Section § 3.1.2, we discussed some of the similarities of the PBC single phase principle and this intermittent serial line system. These systems are only partly similar. PBC systems apply the synchronization mechanism of an intermittent production line for the co-ordination between the stages (the single phase principle), but not the physical layout characteristics and constraints of such a production line system.

In designing a line system, allocating the same type of operation to two separate stations offers no particular advantages. It could only be done either by duplication of machinery or by designing a special type of line layout (U-shaped line) that allows for machine sharing between the stations. The resulting investment costs or co-ordination costs make these solutions unattractive.

However, for PBC systems, such problems do not exist. The serial line system can be modelled according to the PBC definition of stages and the sequence of processing as shown in the left side in Figure 4.12. Each cell receives material from the stage in which it is active, just as we saw in Figure 4.11. The finished products are returned to the stage decoupling stock before the end of the period, but this stock does not need to be located in different locations. PBC controls the release of work to the cells, i.e., the arcs in Figure 4.11. A stage allocation that allows cells to be active in various stages has an impact on the way PBC operates. With such an allocation, the right side in Figure 4.12 would apply. At the start of a period, each cell receives input from different stages, and it has to process the input within one period. If all input is received at the start of a period, the cells operate still in a single phase system. PBC can perform this co-ordination, as it has only consequences for the release decision. If cells deliver each other within the same stage, they operate as in a multi phase system, which makes the co-ordination of the flows too complex for PBC.



**Figure 4.12 New perspectives on PBC synchronization**

The right side in Figure 4.12 shows that the allocation of operations of a cell to separate stages creates no restriction to the material flow between the stages. The cell produces parts that are put in the stage decoupling or transition stock. At the start of a period, the cell is able to obtain all material that needs to be processed within this period from the transition stock. Only where another cell has to perform operations within the same stage in advance (a sequential relationship between the cells within the stage) will this material not necessarily be available at the start of the period, and production has to take place later during the period.

Stage definition in a PBC system is therefore primarily a decomposition of the material flow of the various products from a progress planning point of view. This should be distinguished from the decomposition of the production system itself, such as performed within a serial system. However, stage definition influences the effectiveness of the decomposition of a production system and at the same time, the decomposition of the production system will influence the effectiveness of the planning system structure.

## § 4.5 Summary and conclusions

For the design of a basic unicycle PBC planning system, two factors are very important: stage definition and period length determination. Stage definition has to do with deciding about the number of stages  $N$  and the contents of the stages (which operations to perform when). The contents of the stages affects the performance of the system with respect to flexibility, dependability, and costs. The period length  $P$  has to do with determining the planning frequency and hence the number of set-ups in the system. This has important consequences

for operational issues relating to the production system, such as the *start/finish effect* and the *set-up time effect*. The number of stages  $N$  and the period length  $P$  together determine the manufacturing throughput time and the customer order lead time or forecast horizon. Relevant aspects of the planning system as well as the production system have to be taken into account when determining these factors, as the design of the planning system and the production system are interrelated. If the structure of the production system is designed without an understanding of an appropriate planning system structure, huge inefficiencies can result. The relationship between the design of a suitable structure for the production system and the design of the structure of the planning system is not unidirectional, as often is supposed in literature on production or planning system design. However, a good fit between the production system and the planning system is required to obtain short throughput times or achieve other system objectives. Reduction of throughput times cannot be achieved fully if only one of these systems is redesigned. Traditional approaches to planning system design, such as in MRP or Kanban literature, often apply a decomposition of the planning system that resembles the existing departmental, cell or work centre structure, without taking notice of the possibility of finding a better way to decompose the production system, one that takes account of the interaction between both systems.

In order to decompose the PBC planning system, we have looked at the stage definition according to processing stages that Burbidge uses in his Production Flow Analysis (PFA) method. We have shown that in PFA, the definition of the 'set of parts' controls the decomposition of the production system. The use of a processing stage decomposition can result in an improved interdepartmental flow. However, a processing stage definition is not directly suitable for finding the best way to decompose the planning system structure. The main reason for this is that the number of processing stages does not give any insight in the complexity of the co-ordination problem between and within the stages. A planning system should be able to adequately handle such complex co-ordination problems and needs to be structured such that this co-ordination can be performed.

With this in mind, we have developed a new framework for identifying the various choices that have to be made in order to determine an adequate structure of the planning system. The first step required within this framework is a formulation of the system objectives and a prioritization of them such that they can be used for guidance in designing the planning system. The various factors that play a role are speed (lead time), dependability (due date performance), flexibility, quality, and costs. However, the weight and priority given to these system objectives varies for each production situation. Therefore, a stage definition cannot be provided without a knowledge of these objectives and their ranking.

The main factors that we consider in our framework for PBC stage definition are related to changes in uncertainty and changes in the required accurateness of control. Both changes may lead to the introduction of a stage decoupling point between two successive processing steps.

The framework allows for stage definitions that involve the presence of multiple cells that are sequentially related within the same stage, as long as there is no substantial change in uncertainty or required accurateness of control. Valid reasons for involving various cells within one stage will be related to economic, group effectiveness, and environmental issues. The framework also allows for the occurrence of a cell in various stages. We have shown that the reduction in work in progress and dependability is a strong argument for choosing this solution, as well as the much smaller work load fluctuation within a cell. However, there are also reasons for not allowing cells to be active in several stages, as it leads to reduced standardization of period production requirements, unstable sequencing policy within cells, and an increased number of sequential relationships with other cells.

We have provided an approach for determining an allocation of operations to stages that takes into account the time/cost trade-off between several system objectives. This approach describes the effect of operation allocation on the length of the longest path within a stage and the effect on the arrival of work load at a bottleneck. The mathematical model is described in Appendix B and can be used to decide about a suitable allocation of operations to the stages.

Stage definition in a PBC system is primarily a decomposition of the material flow of the various products from a progress planning point of view. It determines *when* the operations are performed. This should be distinguished from the decomposition of the production system itself that determines where the operations are performed. The prevailing view on PBC stage definition is its similarity to an intermittent serial line system. PBC systems do apply the synchronization mechanism of such a production line for co-ordination between the stages (the single phase principle), but not the physical layout characteristics and constraints of such a production line system. PBC stage definition can facilitate the effectiveness of a cellular manufacturing system. At the same time, the decomposition of the production system influences the effectiveness of the planning system structure.

---

## Chapter 5 Models and methods for determining a period length P

Chapter Four has shown that both stage definition and period length determination are essential factors in the design of a period batch control system. These factors should be determined with care. However, literature gives little support for an adequate decision about these factors. We have presented a framework that provides some assistance in designing stages. With respect to period length determination, we concluded that there is a lack of understanding and insight on the effect of period length variation in a period batch control system. For our study, we need to gain more insight in this design factor. We will start to fill this gap in the current chapter.

In order to improve our understanding of the effect of period length variation, we will first develop mathematical models for period length determination. These models will also include the effect of several measures that are enabled by a change in the production structure, as discussed in Chapter Four. One of these measures is overlapping production, which splits a batch into several subbatches. Overlapping production is easier applicable in a cellular manufacturing system compared with a functional organized system. We will discuss the effect of several strategies to determine these subbatches on period length and costs. The effect of varying the period length and applying various subbatch strategies on system performance will be addressed in Chapters Six and Seven.

We describe two deterministic approaches for period length determination. Section § 5.1 presents an approach that uses detailed information on operating characteristics of the products. It assumes that the allocation of operations to the stages is known in advance. Next, Section § 5.2 discusses classical economic period determination methods.

Section § 5.3 relaxes the assumption that the contents of the stages are known before the period length is being determined. It combines the two approaches that we discussed. The result is a detailed economic period determination approach for an equal number of subbatches strategy, which is presented and discussed.

Section § 5.4 relaxes the assumption that each operation should apply the same number of subbatches. It models the situation with different numbers of subbatches per operation and distinguishes between nested and non-nested batching policies. We present the required modifications in the model of Section § 5.3 for determining a suitable period length that allows various numbers of subbatches per operation.

Section § 5.5 describes solution methods for this model. It explores the cost structure of the model, and develops three related search heuristics: an enumerative search heuristic that finds a suitable variable batching strategy given a period length P, a progressive search heuristic that finds both a period length P and a suitable variable batching strategy, and finally an exhaustive search heuristic that aims at improving the solutions of the other two heuristics.

Section § 5.6 describes the performance of these three heuristics. Finally, Section § 5.7 concludes this chapter on mathematical models and solution methods for the determination of a period length P.

### § 5.1 Detailed decoupled period determination

This section develops a deterministic mathematical model for period length determination according to the principles of Burbidge that we presented in Section § 4.2.1. These principles assume that the period length has to be determined, given a stage definition. Then, the number of stages N and the contents of the stages are known in advance.

The general restriction on P is described with respect to the throughput time of the products that have to be produced within a stage (e.g., Burbidge, 1975a, New, 1977). The length of the period has to be such that the demand for all products can be fulfilled and hence that all required operations in the stage can be finished within one period. We call this a longest-path oriented lowerbound. We present it in Formula (1), but first we introduce some notation:

*Longest-path oriented lowerbound on period length P*

Define:

$j$  : index of stage,  $j = 1..N$

$h$  : index of product,  $h = 1..H$

$i$  : index of operation,  $i = 1..n_j^h$

$n_j^h$  : number of operations of product  $h$  performed successively in stage  $j$

$p_{hi}$  : processing time of  $i^{th}$  operation of product  $h$

$m_{hi}$  : number of machines that perform the  $i^{th}$  operation of product  $h$

$q_h$  : batch size of product  $h$

$s_{hi}$  : setup time required for  $i^{th}$  operation of product  $h$

P : Period length

$[x]^+$  : nearest integer greater than or equal to  $x$

THEN:

$$P \geq \sum_{i=1}^{n_j^h} \left\{ s_{hi} + p_{hi} \cdot \left[ \frac{q_h}{m_{hi}} \right]^+ \right\} \quad \forall j=1..N, h=1..H \quad (1)$$

We can apply this formula for all sequences of operations that are performed within a stage, i.e. for each path of operations. However, for sake of simplicity we will focus our attention on a single path, the longest path or critical path of operations for a product in a stage.

Formula (1) describes the total time required for producing a batch of  $q_h$  items in stage  $j$ , and the period length  $P$  has to exceed the required time in each stage and for each product. The formula assumes that set-up activities for the next operation cannot start before the preceding operation has finished. If this assumption is not valid, the next machine can prepare for being set up while the former operation of the batch at another machine has not yet finished. This means we have to allow parallel (set-up) activities at different machines for the same batch. We can formulate this in Formula (2) as:

$$\begin{aligned}
 P &\geq \sum_{i=1}^{n_j^h} \left\{ d_{hi} + p_{hi} \cdot \left[ \frac{q_h}{m_{hi}} \right]^+ \right\} && \forall j = 1..N, h = 1..H \\
 d_{hi} &= \max \left[ 0, s_{hi} - \sum_{k=1}^{i-1} \left\{ d_{hk} + p_{hk} \cdot \left[ \frac{q_h}{m_{hk}} \right]^+ \right\} \right] && \forall i = 1..n_j^h
 \end{aligned} \tag{2}$$

We have introduced a new variable  $d_{hi}$ : the delay imposed by the set-up of operation  $i$  not being ready when the batch arrives from the preceding operation.  $d_{hi}$  depends on the internal set-up time of operation  $i$  ( $s_{hi}$ ) and the set-up and processing times of preceding operations. If parallel set-up activities at different machines are not allowed, as in (1), we have  $d_{hi}=s_{hi}$ .

It is important to note that if  $P$  is smaller than the right hand side expression of the second formula, a feasible schedule can still exist. However, such a schedule would require further close-scheduling: subsequent *operations* at a product in a stage will have to be performed in parallel. In (2), we only required that -if possible- set-ups at the subsequent machines are performed before the batch arrives. If overlapping production is applied for operation  $i$  of product  $h$ , the total batch  $q_h$  can be divided into  $nb_h$  equal subbatches  $[q_h/nb_h]^+$ ,  $nb_h \in [1, q_h]$ . After finishing the first subbatch at machine 1, these parts are transferred to the second machine. The last subbatch might contain less items due to rounding differences. Only products with the longest throughput time in a stage need to apply overlapping production in order to reduce  $P$ .

Expression (3) results for  $P$  when overlapping production is allowed and the same number of subbatches is used for all operations of a product  $h$ . We assume that each operation requires a different machine and that  $m_{hi}$  machines are used for operation  $i$  of product  $h$ . The batch of product  $h$  at operation  $i$  is therefore divided over the available number of machines  $m_{hi}$  for this operation.

The subbatch size per machine is then:  $\left[ \frac{q_h}{m_{hi} \cdot nb_h} \right]^+$

$$\begin{aligned}
P &\geq \max_{i=1}^{n_j^h} \left[ r_{hi} + p_{hi} \cdot \left[ \frac{q_h}{m_{hi}} \right]^+ + \sum_{t=i+1}^{n_j^h} \left\{ p_{ht} \cdot \left[ \frac{q_h}{m_{ht} \cdot nb_h} \right]^+ \right\} \right] \quad \forall j = 1..N, h = 1..H \\
r_{hi} &= \max_{l=1}^i \left[ s_{hl} + \sum_{t=l}^{i-1} \left\{ p_{ht} \cdot \left[ \frac{q_h}{m_{ht} \cdot nb_h} \right]^+ \right\} \right] \quad (3)
\end{aligned}$$

$r_{hi}$  is the earliest starting time of the first subbatch of the  $i^{th}$  operation of product  $h$ .

$$\text{If } r_{hi-1} \text{ exists, } r_{hi} = \max \left[ s_{hi}, r_{hi-1} + p_{hi-1} \cdot \left[ \frac{q_h}{m_{hi-1} \cdot nb_h} \right]^+ \right] \text{ which is easier to compute.}$$

**Lemma** If  $nb_h = 1$  (overlapping production not allowed for product  $h$ ), then Formula (2) and (3) are equivalent:

$$nb_h = 1 \Rightarrow \max_{i=1}^{n_j^h} \left[ r_{hi} + p_{hi} \cdot \left[ \frac{q_h}{m_{hi}} \right]^+ + \sum_{t=i+1}^{n_j^h} \left\{ p_{ht} \cdot \left[ \frac{q_h}{m_{ht} \cdot 1} \right]^+ \right\} \right] = \sum_{i=1}^{n_j^h} \left\{ d_{hi} + p_{hi} \cdot \left[ \frac{q_h}{m_{hi}} \right]^+ \right\}$$

**Proof** Appendix C.

We can express  $r_{hi}$  in terms of a start delay  $d'_{hi}$ , which is a modification of  $d_{hi}$ : This makes it easier to relate the earliest starting time at  $i$  with the delays imposed at earlier operations.

$$\begin{aligned}
\text{Let } d'_{hi} &= \max \left[ 0, s_{hi} - \sum_{k=1}^{i-1} \left\{ d_{hk} + p_{hk} \cdot \left[ \frac{q_h}{m_{hk} \cdot nb_h} \right]^+ \right\} \right] \quad \forall h = 1..H, i = 1..n_j^h \\
\text{then: } r_{hi} &= d'_{hi} + \sum_{k=1}^{i-1} \left\{ d'_{hk} + p_{hk} \cdot \left[ \frac{q_h}{m_{hk} \cdot nb_h} \right]^+ \right\}
\end{aligned}$$

Expression (3) describes the maximum of all minimal required throughput times for each product in each stage. It is therefore a *longest-path oriented lowerbound* on the period length P for a given stage definition.

#### *Load oriented lowerbound on period length P*

Expression (3) does not take into account the maximum capacity of each machine in a period. We therefore introduce a second restriction on the period length P that pays attention to the principle of a *load-oriented lowerbound*.

Let the  $i^{\text{th}}$  operation of product  $h$  be performed at machine  $k$ . We denote this by  $i^h \in k$ . The following expression results (Formula (4)):

$$P \geq \sum_{h=1}^H \sum_{i^h \in k} \left\{ s_{hi} + p_{hi} \cdot \left[ \frac{q_h}{m_{hi}} \right]^+ \right\} \quad \forall k = 1..K \text{ machines} \quad (4)$$

Note that the set-up time  $s_{hi}$  is the internal set-up time, i.e., the machine cannot process any job during this set-up time. The various operations  $i^h \in k$  that have to be performed at this machine  $k$  may be allocated to different stages according to this capacity restriction. For the mean work load of the machine in a period, the stage to which operations are allocated does not matter in a basic unicycle PBC system, as we have discussed in Section § 4.4.3.

#### *Relationship between batch size and period length*

The two Formulas (3) and (4) assume that the batch sizes  $q_h$  are given, while  $P$  still has to be determined. However, the batch size of a part directly depends on the expected demand during the sales period for the end products in which it is used. The length of this sales period equals  $P$  and hence  $P$  influences the batch size. We already used the formula  $q_h = D_h \cdot P$  in our description of the set-up effect in Chapter Four, where  $D_h$  is the demand for product  $h$  during a standard time unit (e.g., a year) and  $P$  is also expressed in this standard time unit. If we assume that demand for  $h$  is constant and evenly distributed over time, we can rewrite our problem as in Expressions (5) and (6).

Determine  $P$  and  $nb_h, h = 1..H$ , such that

$$P \geq \sum_{h=1}^H \sum_{i^h \in k} \left\{ s_{hi} + p_{hi} \cdot \left[ \frac{P \cdot D_h}{m_{hi}} \right]^+ \right\} \quad \forall k = 1..K \text{ machines} \quad (5)$$

$$P \geq \max_{i=1}^{n_j^h} \left[ r_{hi} + p_{hi} \cdot \left[ \frac{P \cdot D_h}{m_{hi}} \right]^+ + \sum_{t=i+1}^{n_j^h} \left\{ p_{ht} \cdot \left[ \frac{P \cdot D_h}{m_{ht} \cdot nb_h} \right]^+ \right\} \right] \quad \forall j = 1..N, h = 1..H \quad (6)$$

Equation 5 can be rewritten to 5' under the assumption that  $\left[ \frac{P \cdot D_h}{m_{hi}} \right]^+$  is integer:

$$P \geq \max_{k=1}^K \frac{\sum_{h=1}^H \sum_{i^h \in k} s_{hi}}{1 - \sum_{h=1}^H \sum_{i^h \in k} \frac{p_{hi} \cdot D_h}{m_{hi}}} \quad (5')$$

The approach described above assumes that the allocation of operations to machines as well as the allocation of operations to the various stages is known in advance and does not depend on  $P$ . Therefore the approach does not influence the distribution of work load over the cells during a period, nor does it change the decomposition of the production system.

The model to determine a suitable value for the period length uses detailed information on the processing times and set-up times for making the products. Therefore, we denote this approach as ‘*detailed decoupled period determination*’. *Detailed* because of the type of information needed. *Decoupled* because the decision about the period length does not influence stage definition.

## § 5.2 Classical economic period determination

The problem of period length determination can also be approached from an economic lot sizing point of view. Such an approach makes a trade-off between costs related to the number of ordering periods in a year and costs related to the length of the period. Such an approach is still a decoupled period determination approach, but it requires less detailed information on the operating characteristics, such as processing times and set-up times per operation. Several contributions can be found in literature on production cycle determination.

The economic order interval approach applies the economic batch size formula to determine the optimal order interval for each product. Theory says that if this optimal order interval is used for a product, the minimal total costs of ordering and holding inventory will result. This standard economic ordering approach can be criticised, mainly because it determines an individual order interval per product without taking notice of the relationship with other products that are being produced in the same production system. PBC requires a single period length and hence single order interval for all products. Therefore, it requires an approach that takes into account the various products in the system when determining the economic order interval.

Since the 1960s, several mathematical models are developed that face this problem of determining a single ordering period for a combination of products. Goyal and Satir (1989) present an overview. These models basically minimize a total cost function consisting of (1) a joint cost component  $C$  that is involved each time a new period starts, (2) an extra individual ordering cost component  $sc_h$  if product  $h$  is ordered in a period, and (3) a holding cost component  $hc_h$  for holding one item of product  $h$  during one time unit on stock. The models assume that an item is on average half a period  $P$  on stock. The amount ordered per period is  $q_h = D_h \cdot P$ , where  $P$  is the length of a period (or production cycle) and  $D_h$  the demand per time unit. The total cost function is then assumed to be  $TC$ , which is minimized with respect to  $P$ .

$$TC = \frac{\left( C + \sum_{h=1}^H sc_h \right)}{P} + P \cdot \sum_{h=1}^H \left\{ \frac{1}{2} \cdot D_h \cdot hc_h \right\} \quad \rightarrow \quad P = \sqrt{\frac{2 \left( C + \sum_{h=1}^H sc_h \right)}{\sum_{h=1}^H \{ D_h \cdot hc_h \}}}$$

Note that for the total cost function  $TC$  this interval  $P$  need not result in the lowest cost solution, as we have optimized it with respect to the condition that all products are ordered exactly once per period.

The above presented problem formulation is an example of the continuous time replenishment case. Several variants of this problem on the total cost function and the corresponding optimal solution are available in literature. For example, Boucher (1984) introduced a set-up time component in the cost function. Goyal and Satir (1989) presented an overview of deterministic and stochastic inventory models that allow for joint replenishment. Many of these models try to find different replenishment cycles for sets of inventory items. Within the set, each item has the same cycle length, but between the sets different cycles exists.

The discrete period part replenishment problem is a special variant of this problem, as it allows replenishment only within a single phase context. This work originates from the work of Wagner and Whitin (1958). In these models, the length of the base period (time between the phase moments) is fixed and not discussed. A cycle may consist of several periods.

Shtub (1990) discusses the use of these models in a group technology production situation. He states that a single cycle approach such as PBC can lead to an inefficient use of the production cells due to the possibility that major set-ups will be repeated each period. He presents an improvement heuristic based on the savings algorithm of Clarke and Wright (1963) for the capacitated lot sizing problem. Rachamadugu and Tu (1997) applied dynamic programming to obtain solutions for the uncapacitated problem. Jamshidi and Browne (1993) give an indication of the losses incurred if fixed production cycles are used. Muckstadt and Roundy (1993) describe the joint replenishment problem as a special case of ordering in a two stage serial assembly system. They apply a stationary nested power-of-two policy to obtain a near optimal solution with possibly different cycle lengths for the various part families.

Both approaches can be viewed as originating from a classical total cost perspective. Such a perspective pays no attention to the costs that result if the work load varies in subsequent periods. Literature on aggregate production planning does use such cost functions with respect to hiring/firing policies. Kaku and Krajewski (1995) have applied some of these insights in the determination of ordering cycles and period length.

The classical economic period determination models neither pay attention to the length of the throughput time of the batch in the production system. They are mainly focussed on the length of the production interval, assuming that no (holding) costs are incurred before or after this interval. Therefore, the models have to be revised in order to be suitable for period length determination in a PBC context. Section § 5.3 will develop such a model.

### § 5.3 Modelling detailed economic period determination

We propose to combine the economic approach to determine a suitable order interval with the detailed period determination approach, i.e., we want to include detailed information on the operating characteristics of the system when determining the period length. We have not found such an approach in literature. We denote the procedure as a '*detailed economic period determination*' approach. Note that it is not a decoupled approach. In other words, we relax the assumption that the definition of stages is known in advance before determining a suitable period length. The decisions on the number of stages and the allocation of operations to these stages depends on the length of the period, as has been shown in Chapter Four. Therefore, besides a period length P we will have to determine a stage definition. Stage definition will in our modelling approach be restricted to finding a suitable number of stages N, as this primarily influences the total throughput time in the system. We will also determine if overlapping production can effectively be used between successive operations, as this has an important effect on throughput time, length of period and required number of stages. The modelling approach will not determine a suitable allocation of operations to the stages. It therefore assumes that overlapping production can be applied between any two successive operations unless decided otherwise. The basic idea is to determine the effect of period size P, number of stages N, and number of subbatches  $nb_h$  on three relevant cost factors: holding costs in the system, ordering or set-up costs, and transfer costs:

- Holding costs,  $HC_h$ , are related to the average echelon inventory for product  $h$
- Set-up costs per time unit,  $SC_{hi}$ , are involved each time a set-up of operation  $i$  for product  $h$  is required
- Transfer costs,  $TC_{hi}$ , are related to the number of subbatches of product  $h$  transferred at operation  $i$  (i.e.,  $nb_h > 1$ )

Before we present the model, we will explicate the relationship between these cost factors and the total cost of a PBC system that operates with period length P and number of subbatches  $nb_h$ . The notation that we use is introduced within the text and summarized at page 124.

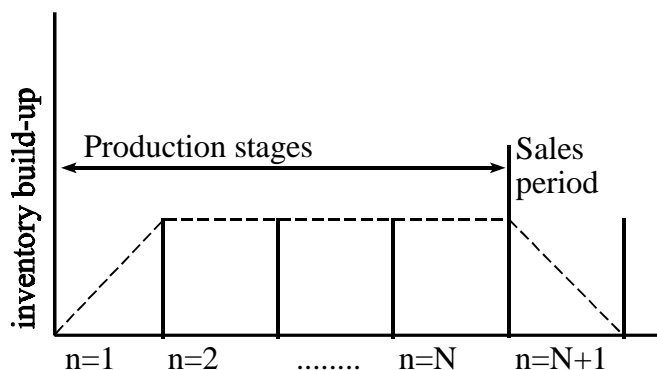

**Figure 5.1 Build up of inventory (WIP and finished goods) during stages**

*holding costs*

First, the cost of holding inventory. We relate these costs to the average amount of inventory in the system, i.e. we use echelon holding costs. In the modelling approach in this chapter, we assume that during the first production stage of PBC, all raw material is introduced into the system when the production activities start. During the next stages, the material is further processed, but no new material is added to the system inventory. When production has finished, the product is available for sale or delivery in stage  $N+1$ . The reason for this assumption is that we can no longer use information on the allocation of operations to the stages, as stage definition has not yet been performed.

Our new period determination approach assumes that on average the raw material is being introduced halfway the first production stage and the final product is sold or delivered halfway stage  $N+1$ , as seen in Figure 5.1. The material that is worked into each product is therefore on average  $N$  stages present in the system, irrespective of the actual progress in making the product (parts, components, sub-assembly, or final product). The average time a batch  $q_h$  that is produced for sales of product  $h$  in stage  $N+1$  is in the system is  $N$  periods of length  $P$ . The average total inventory in the system is then  $\sum_h N \cdot q_h$ .

We compute the holding costs of a single product over the average time the product is in the system. The total holding costs for a product depends on both the average time it is in the system and the cost of holding one item of this product in stock during a standard time unit. This holding cost  $HC_h$  may vary per product  $h$ , to reflect differences in work content, amount and value of material, and so on. However, it is assumed that a good estimation of  $HC_h$  can be obtained without explicit knowledge of the distribution of operations over the various stages. In the next chapter, we will return to this assumption. The total cost of holding this inventory during a standard time unit is  $TCH$ , with

$$TCH = \sum_{h=1}^H \{N \cdot q_h \cdot HC_h\} = N \cdot P \cdot \sum_{h=1}^H \{D_h \cdot HC_h\}$$

The number of stages  $N$  is in our approach a function of the decision variables  $P$  and  $nb_h$ . They directly influence the total time needed for producing a batch of product  $h$ . This total time is denoted as  $TT_h$ , and we can reformulate Formula (3) to determine the length of  $TT_h$ . Note that the number of operations for a product  $n_h$  no longer refers to a specific stage  $j$ .

$$TT_h = \max_{i=1}^{n_h} \left[ r_{hi} + p_{hi} \cdot \left[ \frac{P \cdot D_h}{m_{hi}} \right]^+ + \sum_{t=i+1}^{n_h} \left\{ p_{ht} \cdot \left[ \frac{P \cdot D_h}{m_{ht} \cdot nb_h} \right]^+ \right\} \right]$$

$N$  is an integer. We assume that the PBC system uses  $N$  stages for all products  $h$ :

$$N \geq \max_{h=1}^H \left[ \frac{TT_h}{P} \right]^+ \quad (7)$$

*set-up costs*

The second cost factor is the sum of set-up costs, ordering costs, and other costs that are incurred every time a new cycle starts. These costs will be involved irrespective of the size of the orders or the length of the period. The costs of the frequency of operating the planning system (forecasting effort, program meetings, and so on) are included in these set-up costs. We calculate the set-up cost per standard time unit  $SC_{hi}$  and allocate the costs to the products  $h$  according to the time required per set-up at an operation  $i$ .

In a PBC system, the number of set-ups is  $1/P$  per standard time unit. The set-up costs for an operation are the product of the set-up time for this operation  $s_{hi}$  and its set-up costs per standard time unit  $SC_{hi}$ . In a basic unicycle PBC system, each operation  $i$  of product  $h$  is performed once per period, and this frequency is independent of the stage it is allocated to. We therefore sum the set up times for all  $n_h$  operations of product  $h$ . The total set-up costs *per period* are  $\sum_{h=1..H} \sum_{i=1..n_h} s_{hi} \cdot SC_{hi}$ . Total set-up costs *per standard time unit* is  $TCS$ , with:

$$TCS = \frac{\sum_{h=1}^H \sum_{i=1}^{n_h} \{s_{hi} \cdot SC_{hi}\}}{P}$$

*transfer batch costs*

Finally, we consider the costs of transferring batches between the subsequent operations. These costs depend on the number of subbatches of a product  $h$ :  $nb_h$ . If there is only one batch ( $nb_h=1$ ) then  $TC_{hi}'$  reflects the cost of transportation and administration effort required between the subsequent operations. If the batch of product  $h$  is split into several subbatches ( $nb_h>1$ ), the total transfer costs increase. The transportation and administration activities are performed more often and the utilization of the various operations may decrease as machines have to wait more frequent on the arrival of smaller batches. The extra transfer costs  $TC_{hi}''$  may vary per product and operation. We assume that the extra transfer cost is linear with the number of extra subbatches. Therefore, the transfer costs per standard time unit are  $TCT$ :

$$TCT = \frac{\sum_{h=1}^H \sum_{i=1}^{n_h} \{TC_{hi}' + (nb_h - 1) \cdot TC_{hi}''\}}{P}$$

We obtain the following model, which is a non-linear optimization problem with  $(H+1)$  decision variables.

$$P, nb_h (h = 1..H) \min N \cdot P \cdot \sum_{h=1}^H \{D_h \cdot HC_h\} + \frac{\sum_{h=1}^H \sum_{i=1}^{n_h} \{s_{hi} \cdot SC_{hi} + TC'_{hi} + (nb_h - 1) \cdot TC''_{hi}\}}{P} \quad (8)$$

$$s.t. \{1\} N \geq \max_{h=1}^H \left[ \frac{TT_h}{P} \right]^+ \quad (7)$$

$$\{2\} P \geq \max_{k=1}^K \left[ \frac{\sum_{h=1}^H \sum_{i \in k} s_{hi}}{1 - \sum_{h=1}^H \sum_{i \in k} \frac{p_{hi} \cdot D_h}{m_{hi}}} \right] \quad (4)$$

$$TT_h = \max_{i=1}^{n_h} \left[ r_{hi} + p_{hi} \cdot \left[ \frac{P \cdot D_h}{m_{hi}} \right]^+ + \sum_{t=i+1}^{n_h} \left\{ p_{ht} \cdot \left[ \frac{P \cdot D_h}{m_{ht} \cdot nb_h} \right]^+ \right\} \right] \quad (9)$$

$$r_{hi} = \max_{l=1}^i \left[ s_{hl} + \sum_{t=l}^{i-1} \left\{ p_{ht} \cdot \left[ \frac{q_h}{m_{ht} \cdot nb_h} \right]^+ \right\} \right] = \max \left[ s_{hi}, r_{hi-1} + p_{hi-1} \cdot \left[ \frac{q_h}{m_{hi-1} \cdot nb_h} \right]^+ \right] \quad (3')$$

Restriction{1} and {2} are both lowerbounds, either on the required actual capacity or on the required total time in the system. Restriction{1} neglects the possible product waiting time due to a machine not being ready when the subbatch arrives. At the other hand, Restriction{2} neglects the loss of capacity at machine  $k$  due to overlapping production some products at this machine<sup>1</sup>. Both restrictions assume that the waiting time factor is incorporated in the other restriction, i.e., they are both a lowerbound. We therefore used in both restrictions the greater than or equal to sign.

In a practical optimization approach, one could introduce a correction factor MI in the restrictions, with  $MI \leq 1$ . For example, introducing  $MI=0.95$  in the left side of restriction {2} ( $MI \cdot P \geq ..$ ) indicates that the period length  $P$  has to be determined such that the utilization of any machine  $k$  will not exceed 95%. If we introduce this factor in Restriction{1}, we obtain:

$$N \geq \max_{h=1}^H \left[ \frac{TT_h}{MI \cdot P} \right]^+ \quad (10)$$

<sup>1</sup> The waiting time of either the product or the machine is difficult to estimate, as it is not strictly necessary to start processing a subbatch as soon as it has arrived at the machine. If a machine has lack of capacity, the subbatch may have to wait until the machine is able to process all subbatches subsequently without intermediate waiting times. The machine therefore may introduce an extra product waiting time factor in the total time  $TT_h$  that the product is in the system, in order to reduce its own machine waiting time factor.

Let us summarize the notation that we used in the formulas in this section:

N	Number of stages	
P	Period length	
$nb_h$	Number of (equal) subbatches of product $h$	$h = 1..H$
$TT_h$	Total time required for processing $q_h$ units of product $h$	$h = 1..H$
$n_h$	Number of operations required for product $h$	$h = 1..H$
$D_h$	Demand for product $h$ per standard time unit	$h = 1..H$
$s_{hi}$	Set - up time for $i^{th}$ operation of product $h$ in standard time units	$h = 1..H, i = 1..n_h$
$m_{hi}$	Number of parallel machines that perform $i^{th}$ operation of product $h$	$h = 1..H, i = 1..n_h$
$p_{hi}$	Processing time for $i^{th}$ operation of product $h$ in standard time units	$h = 1..H, i = 1..n_h$
$q_h$	Number of units of product $h$ required per period	$h = 1..H$
$r_{hi}$	Earliest starting time of $i^{th}$ operation of product $h$	$h = 1..H, i = 1..n_h$
$HC_h$	Holding cost for one unit of product $h$ during a standard time unit	$h = 1..H$
$SC_{hi}$	Set - up cost for $i^{th}$ operation of product $h$ per unit of time	$h = 1..H, i = 1..n_h$
$TC'_{hi}$	Transfer cost for the first batch at the $i^{th}$ operation of product $h$	$h = 1..H, i = 1..n_h$
$TC''_{hi}$	Transfer cost for an extra subbatch at the $i^{th}$ operation of product $h$	$h = 1..H, i = 1..n_h$
MI	Machine interference correction factor	

The approach has resulted in an optimization model for determining a period length and a subbatch strategy per product that minimizes the sum of three cost factors. The required number of stages is being determined as the minimal number of periods of length P that is required in order to cover the longest product throughput time  $TT_h$ .

## § 5.4 Modelling different number of subbatches per operation

We have introduced the decision variables  $nb_h$  in the above developed model without paying attention to the possibility of having a different number of subbatches per operation.

However, it may not be optimal to use the same number of subbatches for all operations of a product. An operation at a bottleneck may benefit more from processing a complete batch at a time, while the total throughput time of a product may benefit most if more subbatches are applied at an operation that takes a long processing time.

Within a context of a manufacturing system that is planned and controlled with a PBC system, it may also be better to distinguish between operations that operate with different numbers of subbatches. It will often be more difficult to apply a large number of subbatches for the transfer of material between cells than for transfer within a cell. As the costs will generally be higher for between cell transfer, a manufacturing system would probably prefer only one subbatch at the last operation in a cell in order to transfer the product only once per period to

another cell or stage decoupling stock. However, between other operations within the cell it may apply more subbatches in order to reduce the total throughput time of the batch. Furthermore, the products for which overlapping production should be applied ( $nb_h > 1$ ) may differ per stage. In one stage, product  $h$  may determine the longest throughput time, while in another stage a different product may benefit most from overlapping production. We should therefore allow a different number of subbatches per operation in our model of period length determination.

In order to introduce this possibility in our model, we have to modify the formula for  $TT_h$ . In this formula, we use the number of subbatches to determine the earliest starting time of the first subbatch of the product at the next operation. Let  $nb_{hi}$  denote the number of subbatches at operation  $i$  of product  $h$ . A different number of subbatches per operation means that the number of subbatches at the next operation might differ from the number of subbatches at the former operation. It is then not required that  $nb_{hi} = nb_{hj}$  for  $i \neq j$ . To formulate this situation, we need to modify the determination of the earliest starting time at the next operation.

If we no longer require that  $nb_{hi} = nb_{hj} \forall i \neq j$ , we can distinguish the following cases:

- (a) Non-nested case  $nb_{hi-1} \geq nb_{hi}$
- (b) Nested case  $nb_{hi-1} \leq nb_{hi}$

#### § 5.4.1 Non-nested batching policy $nb_{hi-1} \geq nb_{hi}$

A non-nested batching policy results in the next operation having the total batch divided into a smaller number of subbatches than used at the preceding operation. Between these operations, some waiting time may occur in order to compose the new subbatches, which are now larger than before. If this waiting time is ignored and processing at operation  $i$  starts as soon as the first subbatch of operation  $i-1$  arrives at  $i$ , then not all input material for the first subbatch at  $i$  will be available. This might result in waiting time for both machine and product at operation  $i$  instead of waiting time for the product only, especially if  $p_{hi-1} > p_{hi}$ .

In case of a non-nested batching policy provides the arrival time of the first subbatch of operation  $i-1$  at operation  $i$  not sufficient information for determining the finishing time of this subbatch at operation  $i$ . We need to know this finishing time to determine the earliest starting time at following operations. Therefore, we have to modify the expression that determines the earliest starting time of product  $h$  at operation  $i$ :  $r_{hi}$ .

Let

- $ra_{hi}$  = earliest effective starting time of  $i^{th}$  operation of product  $h$
- $rs_{hi}$  = earliest arrival time of the first subbatch of operation  $i-1$
- $re_{hi}$  = earliest starting time to produce the first subbatch at operation  $i$  without intermediate idle time

We have:

$$ra_{hi} = \max [s_{hi}, rs_{hi}, re_{hi}] \text{ with}$$

$$rs_{hi} = ra_{hi-1} + p_{hi-1} \cdot \left[ \frac{q_h}{m_{hi-1} \cdot nb_{hi-1}} \right]^+$$

$$re_{hi} = ra_{hi-1} + \left( p_{hi} + \{ p_{hi-1} - p_{hi} \} \cdot \left[ \frac{nb_{hi-1}}{nb_{hi}} \right]^+ \right) \cdot \left[ \frac{q_h}{m_{hi-1} \cdot nb_{hi-1}} \right]^+$$

If  $rs_{hi}$  exceeds the set-up time  $s_{hi}$  of operation  $i$ , this operation is allowed to start. However, to determine the earliest effective starting time that can be used for computing the total time needed for product  $h$ , we have to recognize that at operation  $i$  a complete subbatch has to be produced before it can be transferred to operation  $i+1$ . This complete subbatch at  $i$  may be composed of several subbatches of operation  $i-1$ <sup>2</sup>.

The variable  $re_{hi}$  reflects that the arrival time of the last items for the first subbatch at  $i$  determines the finishing time at  $i$ . The earliest starting time at  $i$  is computed using backward scheduling from the arrival time of the last items of the first subbatch at operation  $i$ .

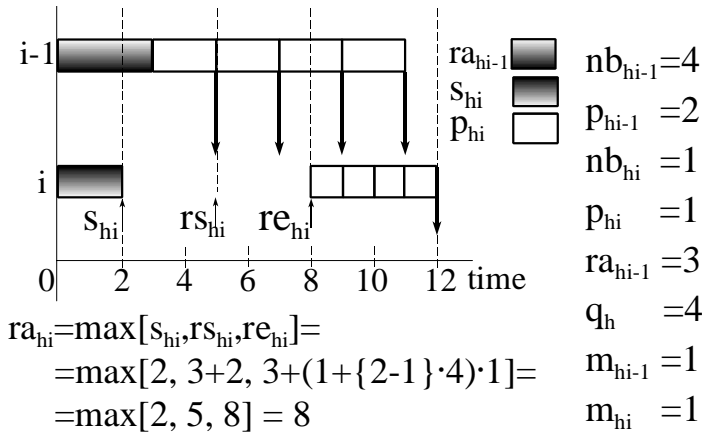

**Figure 5.2** Computing earliest starting time at operation  $i$  in the non-nested case

Figure 5.2 shows an example for which  $ra_{hi}$  is computed. Operation  $i-1$  transfers each unit of product  $h$  as soon as it is ready to operation  $i$ , hence  $nb_{hi}=q_h$ . At operation  $i$ , no transfer of subbatches takes place: the complete batch has to be finished before it is transferred to

<sup>2</sup> The factor  $z = \lceil nb_{hi-1} / nb_{hi} \rceil^+$  denotes the number of subbatches at operation  $i-1$  that have to be completed to obtain sufficient items for the first subbatch at operation  $i$ . From the finishing time of these  $z$  subbatches at  $i-1$  we have to withdraw the processing time of the items that were earlier made available to operation  $i$  through the transfer of subbatches ( $z-1$ ). These ( $z-1$ ) subbatches make it possible to start processing the first subbatch at  $i$  at time  $re_{hi}$  although not all required items are available at this time. The variable  $re_{hi}$  assumes that all items of these ( $z-1$ ) subbatches of operation  $i-1$  have been processed at  $i$  when the  $z^{th}$  subbatch arrives at  $i$ , so  $p_{hi} \cdot (z-1) \cdot \lceil q_h / (m_{hi-1} \cdot nb_{hi-1}) \rceil^+$  (their total processing time) is withdrawn from  $ra_{hi-1} + p_{hi-1} \cdot z \cdot \lceil q_h / (m_{hi-1} \cdot nb_{hi-1}) \rceil^+$ , the earliest finishing time of the  $z^{th}$  subbatch at operation  $i-1$ .

operation  $i+1$ . Consequence of this batching policy is that, although operation  $i$  can start at time 5, it cannot finish before time 12, so starting at time 8 will make it possible to produce the first subbatch without interruption.

Note that a reduction in the number of subbatches at operation  $i-1$  will lead to an increase of the total time needed on the two operations for this product. For example, if  $nb_{hi-1}=2$ ,  $rs_{hi}=7$ ,  $re_{hi}=3+(1+1\cdot2)\cdot2=9$ . The earliest finishing time of operation  $i$  is hence  $9+4=13$ , and the earliest starting time on  $i-1$  is in both cases 3.

The use of  $nb_{hi}=1$  results in less waiting time for the machine that performs operation  $i$ . This is generally preferred at bottleneck machines. However, the introduction of several subbatches at a bottleneck results not necessarily in a lower utilization, as can be seen from operation  $i-1$  in Figure 5.2. If more subbatches are distinguished at an operation, the utilization of the machine that performs this operation depends on the transfer times of the preceding operation and the actual starting time of the operation at the machine. If the actual starting time exceeds the earliest starting time, utilization might increase. Hence, these machines often use a time buffer between the earliest starting time and the actual starting time. The time buffer increases the utilization of these machines, but does also increase the total throughput time of the batch.

Note also that in an actual schedule for machine  $i$  the start of operation  $i$  of product  $h$  may be scheduled before  $re_{hi}$  but not before  $rs_{hi}$ :  $rs_{hi}$  is a strict lowerbound on the actual start of  $i$ .

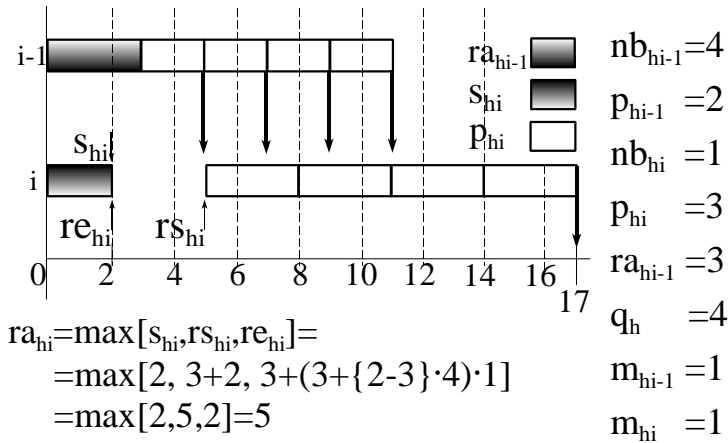

**Figure 5.3**  $ra_{hi}=rs_{hi}$ : operation  $i$  starts without interruption if first subbatch at  $i$  arrives

Figure 5.3 shows a situation where we have  $nb_{hi-1} > nb_{hi}$  but  $re_{hi} < rs_{hi}$ . The situation is identical to the example in Figure 5.2, except the processing time at operation  $i$ :  $p_{hi}$  being 3 instead of 1. We see that the increase in processing time at operation  $i$  results in a different value for the earliest starting time that would make it possible to produce the complete subbatch at  $i$  without interruption ( $re_{hi}$ ) and the earliest starting time due to the arrival of the first subbatch from  $i-1$ :  $ra_{hi}$ . This shows that it is necessary to use both earliest time estimators  $rs_{hi}$  and  $re_{hi}$  when determining  $ra_{hi}$  in the non-nested case  $nb_{hi-1} \geq nb_{hi}$ .

§ 5.4.2 Nested batching policy  $nb_{hi-1} \leq nb_{hi}$ 

The question arises if both earliest time estimators will also be necessary in the other situation that we distinguished, the nested batching policy where  $nb_{hi-1} \leq nb_{hi}$ . The following result is obtained:

Lemma: If  $\{(nb_{hi-1} \leq nb_{hi}) \wedge (nb_{hi} \in [1, q_h]) \forall i = 1..n_h\} \Rightarrow \left[\frac{nb_{hi-1}}{nb_{hi}}\right]^+ = 1 \Rightarrow re_{hi} = rs_{hi}$

$$\begin{aligned}
 \text{Proof: } re_{hi} &= ra_{hi-1} + \left( p_{hi} + \{p_{hi-1} - p_{hi}\} \cdot \left[\frac{nb_{hi-1}}{nb_{hi}}\right]^+ \right) \cdot \left[\frac{q_h}{m_{hi-1} \cdot nb_{hi-1}}\right]^+ = \\
 &= ra_{hi-1} + (p_{hi} + \{p_{hi-1} - p_{hi}\} \cdot 1) \cdot \left[\frac{q_h}{m_{hi-1} \cdot nb_{hi-1}}\right]^+ = \\
 &= ra_{hi-1} + (p_{hi} + p_{hi-1} - p_{hi}) \cdot \left[\frac{q_h}{m_{hi-1} \cdot nb_{hi-1}}\right]^+ = \\
 &= ra_{hi-1} + p_{hi-1} \cdot \left[\frac{q_h}{m_{hi-1} \cdot nb_{hi-1}}\right]^+ = \\
 &= rs_{hi}
 \end{aligned}$$

The reason for this equality is that all parts for the first subbatch at  $i$  are included in the first delivery of a subbatch from  $i-1$ . Therefore,  $ra_{hi} = \max[s_{hi}, rs_{hi}]$  and the time estimator  $re_{hi}$  is no longer required in case of nested batching strategies where  $nb_{hi-1} \leq nb_{hi}$ .

The relationship between the number of subbatches at subsequent operations does influence the completion time of the whole batch for this set of operations. Within the set of nested batching strategies, a subset can be defined that will result in smaller intermediate machine waiting times during the processing of the batch. A strategy within this subset will be denoted as a *powered nested batching policy*, which is defined as follows:

A batching policy  $nb_{hi}$  is powered nested if and only if

$$\exists a, c, y \in \mathbb{N}, \quad a \geq 1, c \geq 2$$

such that

$$nb_{hi} = \frac{q_h}{a \cdot m_{hi}}$$

$$nb_{hi} = c^y \cdot nb_{hi-1}$$

$$nb_{hi} \in \left[ nb_{hi-1}, \dots, \frac{q_h}{m_{hi}} \right] \subseteq [1, \dots, q_h] \subset \mathbb{N}$$

For  $nb_{hi}$  to be powered nested, the next condition must hold:  $\frac{q_h}{m_{hi}} \in \mathbb{N}$

This is a necessary but not a sufficient condition. It is necessary for  $nb_{hi}$  to become integer, but not sufficient for the powered nestedness of  $nb_{hi}$ .

Remark: A powered nested batching policy is a nested policy, as  $nb_{hi} = c^y \cdot nb_{hi-1} \geq nb_{hi-1}$ .

Suitable nested batching policies may a priori be restricted to a specific value of  $c$ . We will denote this by a *power-of- $c$  nested batching policy*, e.g., a power-of-two nested batching policy has  $c=2$ .

The main contribution of powered nested batching policies is in the logistical organization of the batching process. With a powered nested batching strategy, subbatches from earlier operations may be combined into larger subbatches, but this will never require a further division of one of the received subbatches. The received subbatches remain consistent during processing at  $i$ .

The logistical organization of non-powered nested batching policies is more complex. Splitting a batch that just arrived into two<sup>3</sup> subsets results in temporally stocks between operation  $i-1$  and  $i$ , as shown in Figure 5.4. A non-powered nested batching policy may also result in unequal subbatches at operation  $i$ . Unequal subbatches cause extra logistical complexity at this and following operations. Powered nested batching policies do not result in these effects.

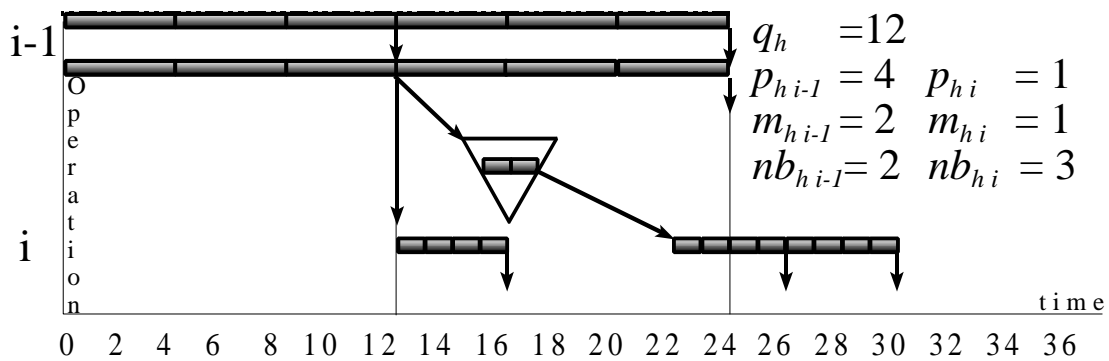

**Figure 5.4 Non-powered nested batching policies result in temporally stock**

If we want to determine a powered nested batching policy for operation  $i$ , we have to find appropriate values for  $a$ ,  $c$ , and  $y$ . We will determine such values for the data that we used in Figure 5.4. The data in this figure describe a problem with a batch size of  $q_h=12$  items. At operation  $i-1$ ,  $m_{hi-1}=2$  machines are available, each using a processing time of  $p_{hi-1}=4$  time units per item. The whole batch is divided into  $nb_{hi-1}=2$  subbatches of six items each. At operation  $i$ , we only have one machine available ( $m_{hi}=1$ ), while the processing time per item  $p_{hi}$  is now equal to 1 time unit.

<sup>3</sup> For example, one subbatch that immediately may start processing and another that has to await processing until the next subbatch from the preceding operation has arrived.

What number of subbatches at operation  $i$  would result in a powered nested batching strategy and what parameters  $a$ ,  $c$ , and  $y$  are necessary to accomplish this?

It is easy to see that  $nb_{hi}=1$  would result in a non-nested policy. For nested policies,  $nb_{hi}$  needs to be  $\geq 2$ . If  $nb_{hi}=nb_{hi-1}=2$ , we require that  $c^y=1$  with  $c \geq 2$ . Hence  $y=0$  and  $a=6$ .

$nb_{hi}$	$a \geq 1$	$c \geq 2$	$y \geq 0$	batching strategy
1	-	-	-	non-nested
2	6	2	0	powered nested
3	4	-	-	non-powered nested
4	-	2	1	powered nested
5	-	-	-	non-powered nested
6	2	3	1	powered nested
7	-	-	-	non-powered nested
8	-	2	2	non-powered nested
9	-	-	-	non-powered nested
10	-	5	1	non-powered nested
11	-	-	-	non-powered nested
12	1	6	1	powered nested

**Table 5.1** Suitable values of  $a$ ,  $c$ , and  $y$  for powered nestedness of  $nb$  at operation  $i$

For  $nb_{hi}=3$  we have already demonstrated that we face a non-powered nested batching policy. This non-powered nested batching policy introduces the possibility of an extra machine waiting time at the next operation  $i+1$ . The second subbatch that will arrive at  $i+1$  consists of items from both the first and the second subbatch that arrives from  $i-1$ . Hence, at operation  $i+1$  we will face some extra machine waiting time between the earliest start moment of the first subbatch at this operation and the earliest finish moment of the last subbatch at this operation, as is illustrated in Figure 5.5, where we compare the non-powered nested batching policy  $nb_{hi}=3$  with the powered nested batching policy  $nb_{hi}=4$ .

For  $nb_{hi}=4, 6$ , and  $12$ , values for  $a$ ,  $c$ , and  $y$  can be found that make them a powered nested batching strategy. However, for  $nb_{hi}=5, 7, 8, 9, 10$ , and  $11$ , we are not able to split the total number of items to be made at a single machine ( $12$ ) in this number of equal subbatches, i.e., we cannot find an appropriate value for parameter  $a$ . In Table 5.1 we have summarized the values that we found for the various subbatch strategies that are possible at operation  $i$ .

We conclude that for this example it is possible to find values that result in powered nestedness of  $nb_{hi}$ .

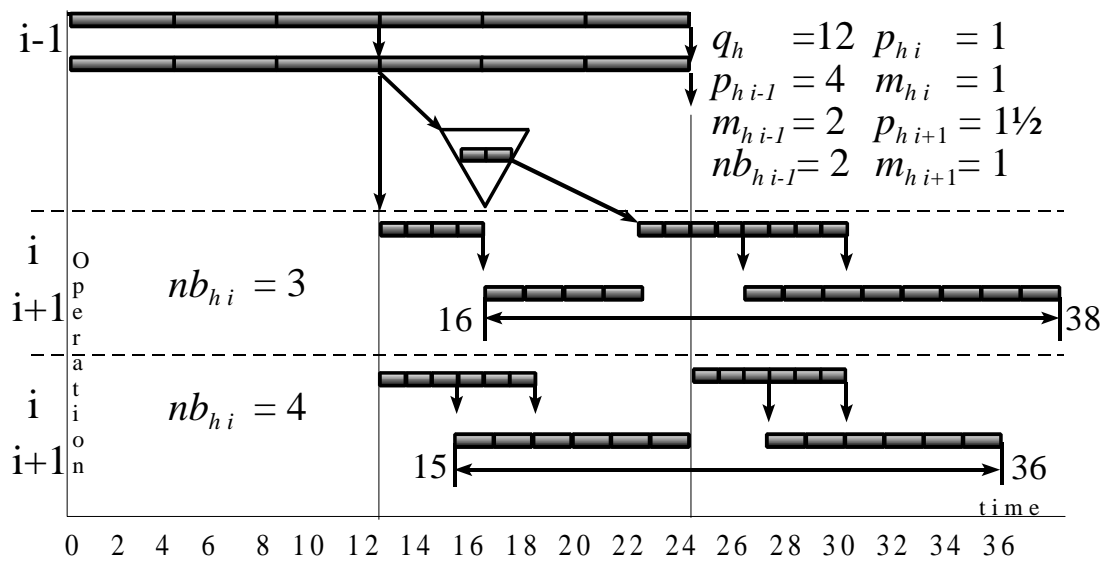

**Figure 5.5** Powered nested batching at  $i$  generate less machine waiting time at  $i+1$

In Figure 5.5 we have the same initial situation as in Figure 5.4, but we have added an extra operation  $i+1$ . The processing time at operation  $i+1$  is  $1\frac{1}{2}$  time unit. If the non-powered nested batching strategy  $nb_{hi}=3$  is used, the next operation can start earliest at time 16. It finishes at time 38, hence a throughput time of at least  $38-16=22$  units at operation  $i+1$ . Note that the processing time at this operation is  $12 \times 1\frac{1}{2}=18$  time units. The powered nested batching strategy  $nb_{hi}=4$  results in a lower throughput time of  $36-15=21$  units. Hence, this strategy results in a lower machine waiting time. Other powered nested batching policies result also in a throughput time of 21, which shows that an idle time of at least 3 time units is unavoidable. However, the non-powered nested batching policy  $nb_{hi}=3$  requires one time unit extra idle time at this operation  $i+1$ , and so increases the machine waiting time.

The reason for this extra delay at  $i+1$  for a non-powered nested batching policy is the delay in the transfer of an intermediate batch from operation  $i$ . This batch contained items from both the first and second subbatch of operation  $i$ . This batch contained items from both the first and second subbatch of operation  $i-1$  and hence had to wait until the second subbatch from operation  $i-1$  arrived at operation  $i$  before processing could be continued. A powered nested batching policy will never allow such a composition of items of several subbatches into one new subbatch for the following operation.

The earliest start of a subbatch at  $i$  is for powered nested batching policies only a function of:

- the arrival time of the subbatch of  $i-1$  that contains all its items
- the number of preceding subbatches that also contained items from this subbatch of  $i-1$
- the set-up time at  $i$  (assumed to be negligible in example)
- the processing time at  $i$

In case of powered nested batching policies, we do not have to correct for the effect of incomplete batches, as was done in the function  $re_{hi}$  for non-nested batching policies. To conclude, the discussion on different number of subbatches in subsequent operations has shown that for non-nested batching policies it is more difficult to determine the earliest effective starting time of an operation such that a machine can start producing without facing intermediate idle time. For nested batching strategies, this problem no longer exists. Within the set of nested policies, we have distinguished the subset of powered nested batching policies, which result in less logistical organization and co-ordination problems. Nested batching policies that are non-powered might result in extra machine waiting times and hence longer throughput times at this operation.

From this, we may not conclude that a powered nested batching policy should always be preferred. We have shown two cases where its application generates good results. Firstly, the situation where preceding operations have more machines available to produce the batch than available at operation  $i$ . Secondly, the situation where idle time at bottleneck operations has to be minimized. However, in deciding about a batching policy, we do not always aim at minimizing the total time needed for the sequence of operations, nor the idle time at each machine. The more general objective of minimizing total cost with respect to available capacity allows for using various batching policies. Next, we present a mathematical model for determining both P and a suitable subbatch strategy that tries to minimize total cost. Total costs are considered a function of the total time needed, the cost of set-ups, and the cost of subbatch transfers.

### § 5.4.3 Period length determination with (non)-nested batching policies

The model for determining a suitable period length that we described in Expression (8) has to be modified to incorporate the presence of various batching policies. The number of decision variables increases, as we have to determine for each operation  $i$  of a product  $h$  a possibly different number of subbatches. The number of constraints remains equal, but computation of Constraint {1} has to be modified, as the total time a product is in the system depends on the batching strategy at each operation. We apply a recursive expression for determining the earliest effective starting time for any subbatch at an operation  $ra_{hi}(j)$  in (14). Our formulation includes both the non-nested and the nested subbatching strategies. This makes the expression quite complicated.

Define:

$ra_{hi}(j)$  = earliest effective starting time of the  $j^{th}$  subbatch at the  $i^{th}$  operation of product  $h$   
 $[x]$  = nearest integer smaller than or equal to  $x$

Constraint {2} does not change in the modified model, although we have shown that the amount of idle time at an operation  $i$  depends on the batching policy at the preceding operation  $i-1$ . The reason for this is that the idle time between the operations can be avoided by postponing the start of the operation. Therefore, the capacity-based lowerbound on the period length does not change.

We obtain the following model:

$$\min_{P, nb_{hi}} N \cdot P \cdot \sum_{h=1}^H \{D_h \cdot HC_h\} + \frac{\sum_{h=1}^H \sum_{i=1}^{n_h} \{s_{hi} \cdot SC_{hi} + TC'_{hi} + (nb_{hi} - 1) \cdot TC''_{hi}\}}{P} \quad (11)$$

$(i = 1..n_h, h = 1..H)$

$$s.t. \quad \{1\} \quad N \geq \max_{h=1}^H \left[ \frac{TT_h}{MI \cdot P} \right]^+ \quad (10)$$

$$\{2\} \quad P \geq \max_{k=1}^K \left[ \frac{\sum_{h=1}^H \sum_{i^h \in k} s_{hi}}{1 - \sum_{h=1}^H \sum_{i^h \in k} \frac{p_{hi} \cdot D_h}{m_{hi}}} \right] \quad (4)$$

$$TT_h = \max_{i=1}^{n_h} \left[ ra_{hi}(nb_{hi}) + p_{hi} \cdot \left[ \frac{P \cdot D_h}{m_{hi} \cdot nb_{hi}} \right]^+ + \sum_{t=i+1}^{n_h} \left\{ p_{ht} \cdot \left[ \frac{P \cdot D_h}{m_{ht} \cdot nb_{ht} - 1} \right]^+ \right\} \right] \quad (12)$$

$$ra_{hi}(1) = \max \left[ s_{hi}, \quad ra_{hi-1}(1) + p_{hi-1} \cdot \left[ \frac{P \cdot D_h}{m_{hi-1} \cdot nb_{hi-1}} \right]^+, \quad ra_{hi-1}(1) + \left( p_{hi} + \{p_{hi-1} - p_{hi}\} \cdot \left[ \frac{nb_{hi-1}}{nb_{hi}} \right]^+ \right) \cdot \left[ \frac{P \cdot D_h}{m_{hi-1} \cdot nb_{hi-1}} \right]^+ \right] \quad (13)$$

$$ra_{hi}(j) = \max \left[ \begin{aligned} & ra_{hi}(j-1) + p_{hi} \cdot \left[ \frac{P \cdot D_h}{m_{hi} \cdot nb_{hi}} \right]^+, \\ & ra_{hi-1} \left( \left[ \frac{1}{P \cdot D_h} + \{j-1\} \cdot \frac{nb_{hi-1}}{nb_{hi}} \right]^+ \right) + p_{hi-1} \cdot \left[ \frac{P \cdot D_h}{m_{hi-1} \cdot nb_{hi-1}} \right]^+ + \\ & \left\{ (j-1) \cdot \frac{nb_{hi-1}}{nb_{hi}} - \left[ (j-1) \cdot \frac{nb_{hi-1}}{nb_{hi}} \right]^- \right\} \cdot p_{hi} \cdot \left[ \frac{P \cdot D_h}{m_{hi} \cdot nb_{hi-1}} \right]^+, \\ & ra_{hi-1} \left( \left[ j \cdot \frac{nb_{hi-1}}{nb_{hi}} \right]^+ \right) + p_{hi-1} \cdot \left[ \frac{P \cdot D_h}{m_{hi-1} \cdot nb_{hi-1}} \right]^+ - \\ & \left\{ j \cdot \frac{nb_{hi-1}}{nb_{hi}} - \frac{1}{P \cdot D_h} \right\}^- - (j-1) \cdot \frac{nb_{hi-1}}{nb_{hi}} \cdot p_{hi} \cdot \left[ \frac{P \cdot D_h}{m_{hi} \cdot nb_{hi-1}} \right]^+ \end{aligned} \right] \quad (14)$$

Expression (13) determines the earliest effective starting time of the first subbatch at operation  $i$ . The expression directly relates to the one presented in Section § 5.4.1 on non-nested batching. It consists of the maximum of three variables: the set-up time at the current operation  $i$ , the earliest arrival time of the first subbatch from the preceding operation, and the earliest starting time for which the first subbatch at operation  $i$  can be completed without intermediate waiting time. The latter factor is only necessary in case of non-nested batching strategies.

Expression (14) determines the earliest starting times of the following subbatches at this operation. It also consists of the maximum of three variables. The first variable is simply the sum of the earliest effective starting time of the preceding subbatch at this operation and the processing time of one subbatch at this operation. The second variable determines the arrival time of the subbatch from the preceding operation that contains the *first* element of the  $j^{\text{th}}$  subbatch at operation  $i$ . In order to identify this originating subbatch at operation  $i-1$ , we developed a transformation of  $j$  to  $o_{i-1}$ :

Originating subbatch  $o_{i-1}$  at  $i-1$  containing first element of  $j^{\text{th}}$  subbatch at operation  $i =$

$$o_{i-1} = \left[ (j-1) \cdot \frac{nb_{hi-1}}{nb_{hi}} + \frac{1}{q_h} \right]^+$$

The factor  $1/q_h = 1/(P \cdot D_h)$  indicates the first element of the  $j^{\text{th}}$  subbatch. This arrival time consists of the earliest effective starting time at the preceding operation and the processing time of the  $o_{i-1}^{\text{th}}$  subbatch at that operation. We have to add a factor consisting of the processing time of elements in this  $o_{i-1}^{\text{th}}$  subbatch that have to be processed in the  $j-1^{\text{th}}$  subbatch at operation  $i$ . The processing time of these elements at operation  $i$  is:

$$\left\{ (j-1) \cdot \frac{nb_{hi-1}}{nb_{hi}} - \left[ (j-1) \cdot \frac{nb_{hi-1}}{nb_{hi}} \right]^- \right\} \cdot p_{hi} \cdot \left[ \frac{P \cdot D_h}{m_{hi} \cdot nb_{hi-1}} \right]^+$$

The third variable in Expression (14) determines the earliest arrival time of the last item in the  $j^{\text{th}}$  subbatch at  $i$ . Again, we compute the earliest starting time of the originating subbatch at  $i-1$ , and add the processing time of this batch at  $i-1$ . However, we do not need to await the completion of this whole batch at  $i-1$  before we start at  $i$ , and hence we subtract the amount of processing time at  $i$  that already can be scheduled because of items originating from earlier subbatches.

This completes our discussion on a variable batching strategy within a detailed economic period determination approach. We have worked it into a mathematical model for determining the period length P in a PBC system. In the next sections, we will explore and develop solution approaches for this model and show the effect of period length on the various cost factors in a PBC system.

## § 5.5 Solution methods for detailed economic period determination model

We have developed a mathematical model for determining a period length  $P$  and a variable subbatch strategy. The model calculates the minimal number of stages  $N$  that will be necessary in order to finish a product within the available throughput time  $N \cdot P$ . In finding appropriate values for these variables, it tries to minimize the sum of inventory holding costs, set-up costs, and costs for the transfer of subbatches between operations.

In general, there will be no solution methods available that are able to solve this model to optimality. This is due to the integer restrictions, the number of decision variables, and the non-linearity of the constraints. These aspects make it quite difficult both to obtain and to prove optimality of a solution. However, we are not primarily interested in finding such an optimal solution. We want to gain insight in the effect of period length and other PBC design factors on system performance. Therefore, we will already be satisfied when we are able to improve our understanding of the problem through the identification of feasible solutions and good approximations of the optimal solution. A heuristic approach may be used to provide these approximations.

In order to develop such a heuristic solution approach, we will use insights from literature on related problems, presented in Appendix D, and insights on the cost structure of the model with equal subbatches. This will help us to identify general principles for solutions of this model. Literature provides no direct solution approach for our model. We therefore develop a search procedure that tries to find a solution on a restricted domain. The value of such a solution approach is stressed by Williams, Tüfekci and Akansel (1997). It seems useful to solve our model subsequently for various values of  $N$  (the number of stages). This means, we have to minimize the sum of a linear holding cost ( $N$  is fixed) and the set-up + transfer costs subject to a constraint with respect to the minimum and maximum value of the make span for which the value of  $N$  holds. This heuristic search approach is described in Section § 5.5.2, but first we have to improve our understanding of the cost structure of our model. This will help us to develop a more efficient search procedure, for the number of decision variables is high.

First, we discuss the cost structure of the equal subbatch model in Section § 5.5.1. We use data from an example problem that is introduced in this section. In the next Section § 5.5.2 we introduce the enumerative search heuristic, an initial solution approach for general model, and discuss the results for the illustrative example. The enumerative search heuristic finds a suitable variable batching strategy *given* a value of the period length  $P$ . Section § 5.5.3 presents a progressive search heuristic that finds both a period length  $P$  and a variable batching strategy. Finally, we present an exhaustive search heuristic that further tries to improve the solutions found by the other two heuristics, and compare the results.

## § 5.5.1 Exploring the cost structure of the model with equal subbatches

We have to improve our understanding of the sensitivity of our model for changes in the decision variables period length and subbatch strategy, in order to develop a suitable and efficient heuristic solution approach. We will first present the data of a simple example problem for which we are able to show the consequences of changes in the decision variables.

*Example problem*

Table 5.2 shows the data of the example problem. We consider only two products with a known yearly demand. The first product requires nine operations, the other product eight. All operations are performed at different machines or cells, and for each operation we have just one machine available. In total, we have seventeen machines in our system and there is no interaction between the products on any resource. Machines that perform operations for the same product all have both identical set-up times and identical item processing times.

$h$	Product index	1	2	
$D_h$	Demand	1040	800	products per year
$n_h$	number of operations for product $h$	9	8	operations per product
$s_{hi}$	Set-up time operation $i$ (years)	0.00721	0.00577	years $\forall i=1..n_h$
	Set-up time operation $i$ (hours)	15	12	hours $\forall i=1..n_h$
$p_{hi}$	Processing time operation $i$ (years)	0.00048	0.00072	years $\forall i=1..n_h$
	Processing time operation $i$ (hours)	1	1.5	hours $\forall i=1..n_h$
$m_{hi}$	number of machines for operation $i$	1	1	machine $\forall i=1..n_h$
$P_{min}$	Minimum period length (capacity)	0.01442		years = 3.75 days
$HC_h$	Holding costs	4		per unit per year
$SC_{hi}$	Set-up costs	50		per set-up $\forall i=1..n_h$
$TC'_{hi}$	Transfer costs per proces batch	0.4		per batch $\forall i=1..n_h$
$TC''_{hi}$	Transfer costs per extra subbatch	0.4		per transfer $\forall i=1..n_h$

**Table 5.2 Data example problem**

For this example problem, we have to determine a period length  $P$ , and a subbatch strategy. In order to explore the cost structure of the model, we restrict our attention first to the equal subbatch situation: a product uses the same number of subbatches at each operation. As we have only one machine per operation in our example problem, one of the reasons for preferring a variable subbatch strategy is not present. Usage of a variable subbatch strategy in the exploration of the cost structure results in a huge increase of the number of decision variables. Therefore, we restrict our attention in this section to the equal subbatch strategy.

The mathematical model calculates from the values of the decision variables  $P$  and  $nb_h$  the total throughput time of each product in the system  $TT_h$  (Formula (9)). Subsequently, the required number of stages  $N$  can be calculated according to Formula (7) and the costs of the solution according to (8).

Figure 5.6 shows the various partial cost curves as well as the total cost curve as a function of the period length  $P$  for the example problem<sup>4</sup> with two subbatches ( $nb_h = 2$ ) for all products.

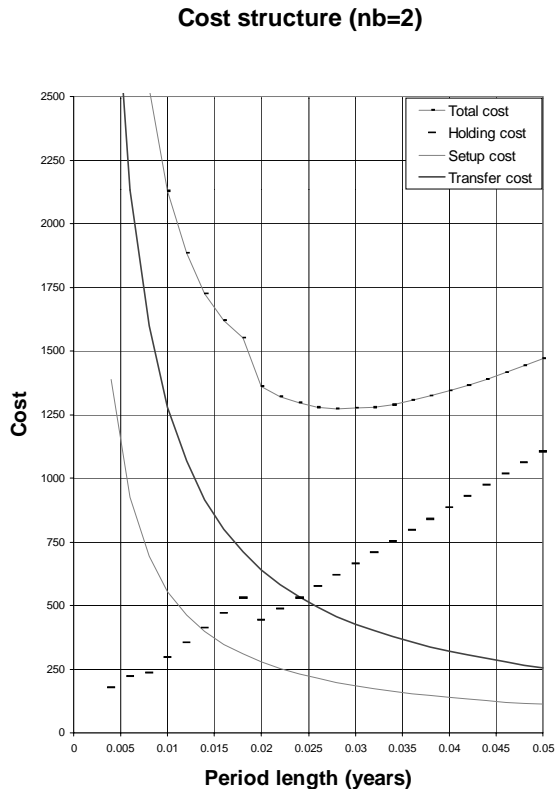

**Figure 5.6 Partial and total cost curves**

Both the set-up cost curve  $S_{cost}$  and the transfer cost curve  $T_{cost}$  show a rather familiar pattern: the costs are high if the period length is small, because the number of set-ups and transfers are a linear function of the number of periods, and this number is inversely proportional to the period length.

The holding cost function  $H_{cost}$  does show a less familiar pattern. The curve is discontinuous and has two breakpoints (at  $P \approx 0.008$  and  $P \approx 0.019$ ). These breakpoints are caused by the decrease in the number of stages required to produce a batch of products if  $P$  increases. Batch sizes increase linearly with the period length, as  $q_h = P \cdot D_h$  and the holding costs depend on the amount of units in the system. However, holding costs also depend on the total time  $TT_h$  these units stay in the system. If the period length increases, the throughput time of the batch can be divided amongst a decreasing number of stages. If a reduction in the number of stages occurs, this reduces the amount of items in the system and hence the holding costs.

<sup>4</sup> In Figure 5.6 we have included small period lengths that are in fact infeasible if no parallel machines are applied. However, we think this gains more insight in the cost structure. In developing a solution approach, we will consider the capacity limits of the system.

Discontinuity of one of the partial cost functions results in discontinuity of the total cost function *Total*. That means that we cannot simply differentiate this function to obtain a minimum. We have to apply a more refined search procedure that checks on the possible value of N (the number of stages) at a specific period length P. Furthermore, we may also have to search for a suitable and cost effective subbatch strategy. In Figure 5.6 we fixed the number of subbatches at two for all products. However, it may be possible to find lower cost solutions with other numbers of subbatches. We therefore first explore the change in the cost structure if we apply other numbers of subbatches for all products before we develop a search approach for a period length P.

Figure 5.7 illustrates the effect of an increasing number of subbatches on the total cost curves. It consists of four figures, each representing a specific number of subbatches, respectively  $nb=1$  (i.e. no extra transfer batches),  $nb=2$ ,  $nb=3$  and  $nb=4$ . Note that in all situations we have an equal number of subbatches policy:  $nb_{hi} = nb_h \forall i=1..n_h$ , and we use the same number of subbatches for all products  $nb_h = nb \forall h=1..H$ .

Each figure in Figure 5.7 shows seven total cost curves, for  $N=1,2,\dots,7$ . These cost curves represent the total cost as a function of the period length P if exactly  $N=n$  stages are used to produce the batches. We call these curves *conditional cost curves*, as they assume that  $N=n$ , independent of the period length. The lowest conditional cost curve is of course  $N=1$ . For a specific value of P, the total cost becomes higher as N increases. The actual total cost curve for the specified batching policy may be discontinuous, but will proceed along the conditional cost curves in these figures. This actual cost curve is identified with the underscore symbol.

Figure 5.7a shows the conditional cost curves if no batch splitting is applied and Figure 5.7b if  $nb=2$ . We will first concentrate on the changes that occur in the conditional cost curves due to the increasing number of subbatches. We see that all conditional cost curves show both a *rightward shift* and an *upward shift*: the total cost increases due to the higher number of transfers, both per period and over the year. This cost increase is strongest if the period length is small, as this leads to a high number of periods a year. The curve shifting leads to an important change with respect to the period length for which the curves have their minimum conditional total cost. We conclude that:

*the optimal period length increases if the number of subbatches increases.*

If we further take a look at Figure 5.7c and Figure 5.7d we find that the distance between the optimal period length for conditional cost curve  $N=n+1$  and the optimal period length for curve  $N=n$  increases as the number of subbatches increases. We conclude that:

*the optimal period length becomes increasingly sensitive  
for changes in the number of stages N  
if the number of subbatches increases.*

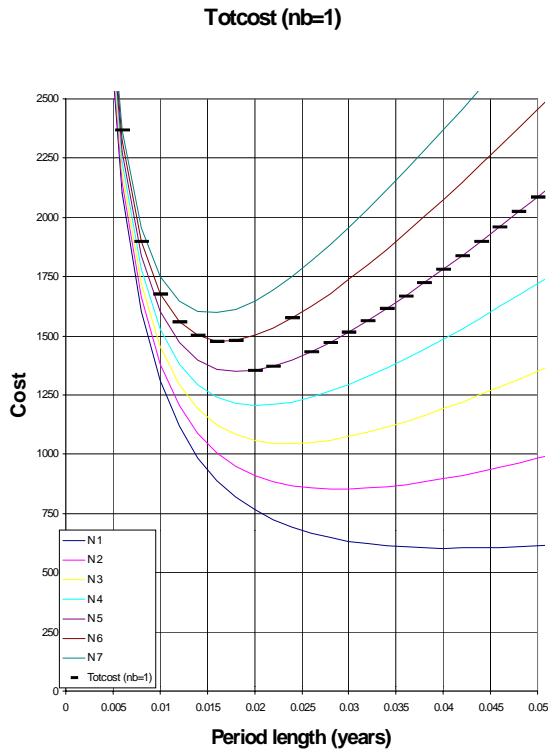

**Figure a** Cost curves for  $nb=1$

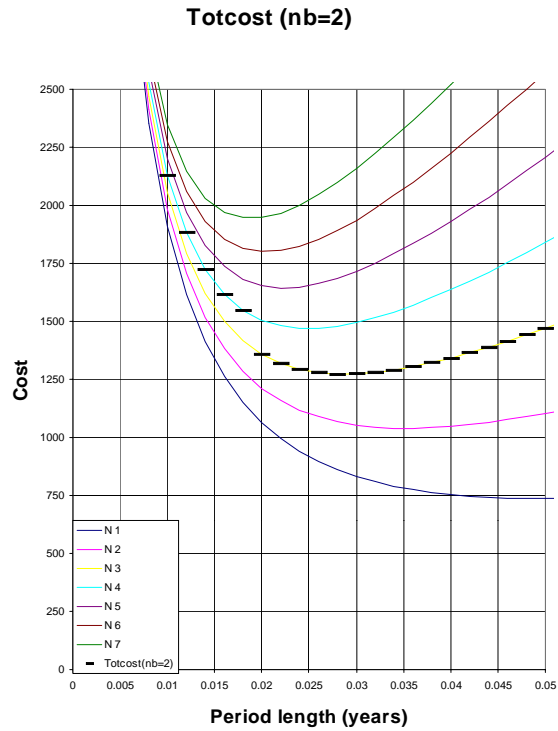

**Figure b** Cost curves for  $nb=2$

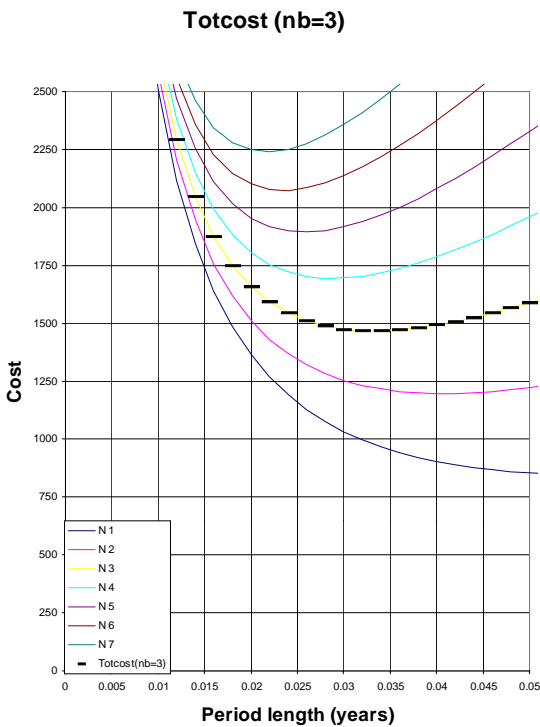

**Figure c** Cost curves for  $nb=3$

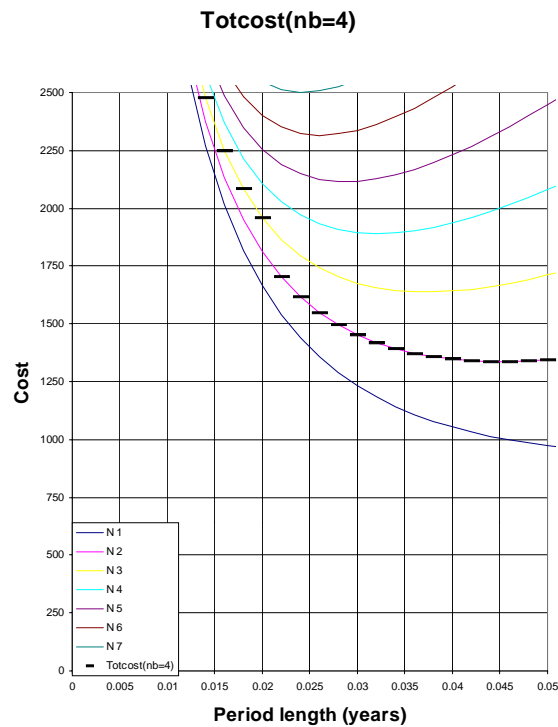

**Figure d** Cost curves for  $nb=4$

**Figure 5.7** Conditional and actual total cost curves for increasing numbers of subbatches

Both effects can be used in designing an adequate solution procedure for the general problem of finding both suitable values for the number of subbatches per operation and for the period length in order to minimize total cost.

We now pay attention to the change in the *actual* cost curves if we increase the period length P (while still applying an equal number of subbatches strategy). Remind that these curves are identified with the underscore symbol in the Figure 5.7a-d. The actual cost curve for  $nb=1$ ,  $nb=2$  and  $nb=4$  are all discontinuous in the selected domain of period length values, so there occurs a change in the required number of stages due to a change in the period length.

If  $nb=1$ , the valid N-values are 6 (or higher) if P is smaller than 0.02, and 5 for period lengths higher than this breakpoint, as shown in Figure 5.7a. The minimum cost (1354) is found at the breakpoint. That means that at this period length for at least one product  $h$  the throughput time  $TT_h$  almost equals the available time of  $P \cdot N$ , where  $N=5$ . A slightly smaller period length P leads to a higher required number of stages. A further increase of the period length normally leads to somewhat more slack between throughput time and available time. Eventually this may lead to a further decrease of the required number of stages.<sup>5</sup>

The actual cost curve at  $nb=2$  is found at  $N=4$  and  $N=3$ . The actual cost at this batching policy is much lower compared with  $nb=1$ , as the reduction in holding costs exaggerates the increase in transfer costs<sup>6</sup>. The minimum cost for  $nb=2$  is not found at a breakpoint, but at the minimum of the conditional cost curve  $N=3$ :  $P=0.028$  with a total cost of 1274.

If we further increase the number of batches to  $nb=3$ , the actual cost curve is found at  $N=3$ . The optimum is found at a higher P (0.034) with a higher total cost 1467. Note that we see here the effect of both the upward and rightward shift of the conditional cost curve of  $N=3$ . The minimum is taken at a higher P and the total cost is higher if the number of subbatches increases while the required number of stages remains the same. The actual minimal total cost as a function of the number of subbatches decreased when  $nb$  increased from 1 to 2, but increased when  $nb$  increased to 3. If we still further increase the number of subbatches to 4 (Figure 5.7d), a new breakpoint occurs at  $P=0.022$ , decreasing the required number of stages to 2. The minimum cost occurs at  $P=0.046$  with a cost of 1337. So the further increase of the number of subbatches reduces the minimal total cost compared with  $nb=3$ . However, if we

<sup>5</sup> Remark the momentary increase of the actual cost curve for  $nb=1$  at  $P=\pm 0.024$ . At this period length the batch size  $[P \cdot D_2]^+$  is between 19 and 20. For the computation of the batch throughput time we use an integer valued number of items per batch. The increase in the batch size leads at this P value to a permanent increase in the required throughput time and a temporary increase in the required number of stages. Therefore, the discontinuity of  $TT_h$  as a function of P causes  $N \geq [TT_h/P]^+$  to be no strictly non-increasing function of P. If the number of subbatches increases, this effect may again show up, due to an increase of rounding up errors.

<sup>6</sup> Figure 5.8 shows the differences between the actual cost curves in one graph. Note that it amplifies the differences through the selection of a different scale of the Y-axis.

compare this solution with the solution of  $nb=2$ , we see that the holding cost reduction (one stage less) is not enough to overcome the increase in transfer costs (two transfer batches per operation per period extra). Figure 5.8 summarizes the differences between the actual cost curves for the four batching strategies discussed. Note the different scale of the Y-axis compared with Figure 5.7.

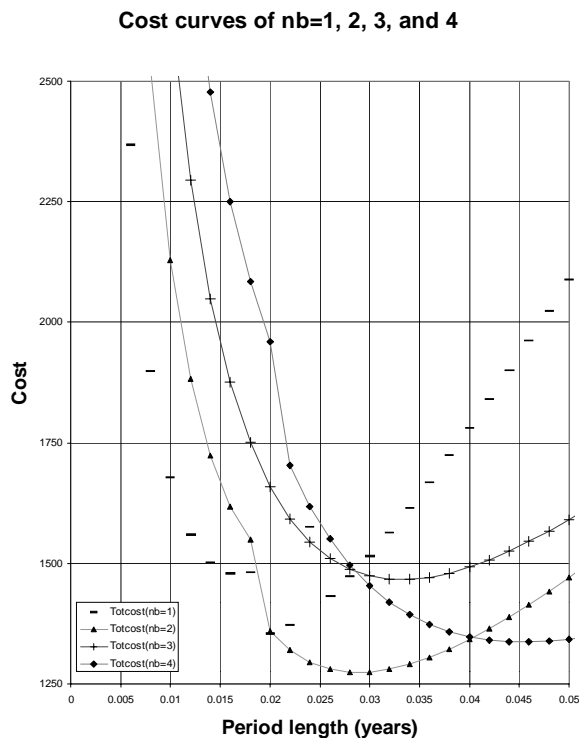

**Figure 5.8 Change in actual cost curves for various equal number of subbatch policies**

The effect of an increase in the number of subbatches on the required throughput time obeys the law of diminishing marginal returns. This effect can be seen from Figure 5.8 and is also known from research on related problems that we discuss in Appendix D, such as lot streaming and repetitive lot problems. The cost of an increase in the number of subbatches is linear with both the number of subbatches and the number of periods. Due to the law of diminishing returns, there will either be a number of subbatches for which the extra transfer costs exceeds the benefits of a further reduction of the throughput time (lower holding costs), or the minimal number of stages has been reached earlier. In the example,  $N=1$  is reached for  $P=0.11$  and  $nb=11$ , resulting in a minimal cost of 1467, which illustrates that a huge increase in the number of transfer batches is needed to further reduce the number of stages.

We conclude that an increase in  $P$  has an important effect on total costs, due to the reduced number of stages after a breakpoint. The number of subbatches has a strong impact on both throughput time and transfer costs. A solution approach should consider this complex relationship.

### § 5.5.2 Variable batching strategies: an enumerative search heuristic

The insight that we gained on the relationship between costs, period length, number of stages and subbatch strategy are based on the use of an equal number of subbatches for all operations and all products. Such a batching policy is very transparent and easy to use, but may result in reducing throughput times of products without any effect on the required number of stages, but with effect on costs. In fact, in a PBC system we should use overlapping production only for products with throughput times longer than the available time in a stage. As we not yet have defined the stages, we can relax this criterion to the use of a higher number of subbatches only if it helps to reduce the total manufacturing throughput time  $N \cdot P$  and consequently helps to minimize total cost, according to our formulation of the equal subbatch model in Formula (8) or the variable subbatch model in Formula (11). The latter distinguishes subbatch strategies between the products as well as between the operations.

It may be difficult to find suitable values for the variables  $nb_{hi}$ , even for a restricted number of products  $h$ . There is no standard solution for the problem of determining values for  $nb_{hi}$  that minimizes total cost for a given period length  $P$ . Appendix D discusses several solution procedures from literature. For the general problem, we can only derive approximations of the optimal solutions. Such heuristic approaches may therefore even find solutions that have larger total costs than an equal number of subbatches strategy. We have experimented with the solution described in Graves and Kostreva (1986), but with their method for determining the number of batches (described in Appendix D), we obtained disappointing results for total costs. Hence, we decided to design a new heuristic.

#### *Enumerative search heuristic*

The *enumerative search heuristic* finds feasible values for  $nb_{hi}$  given a period length  $P$ . It starts with an initial (large) number of stages  $N$ , and an equal subbatch strategy where all products have only one subbatch ( $nb_{hi}=1$ ). The enumerative search heuristic directs its attention to finding breakpoints in cost curves that depend on  $N$  and  $nb_{hi}$ , compares the solutions for these breakpoints, and selects the batching strategy that causes the lowest total cost. The heuristic determines an increase in the number of subbatches per operation only for operations for which it is allowed to find multiple subbatches, i.e., the user may provide the heuristic with a maximum number of subbatches at a specific operation. The increase in the number of subbatches at this operation is based on information with respect to the location of the breakpoints and the expected reduction in the total throughput time<sup>7</sup>. All products whose throughput times have to be shortened are considered. Figure 5.9 describes the enumerative search heuristic in detail.

<sup>7</sup> The estimated reduction in throughput time due to an increase in the number of subbatches at operation  $i$  depends in the heuristic on the ratio of processing time and number of machines for this and the successive operation  $i+1$ . If this ratio is smaller for operation  $i$ , we estimate the decrease of throughput time as one (resized) subbatch times the processing time at  $i$ . If the ratio is smaller for operation  $i+1$ , we take into account the effect it has on operation  $i+1$ .

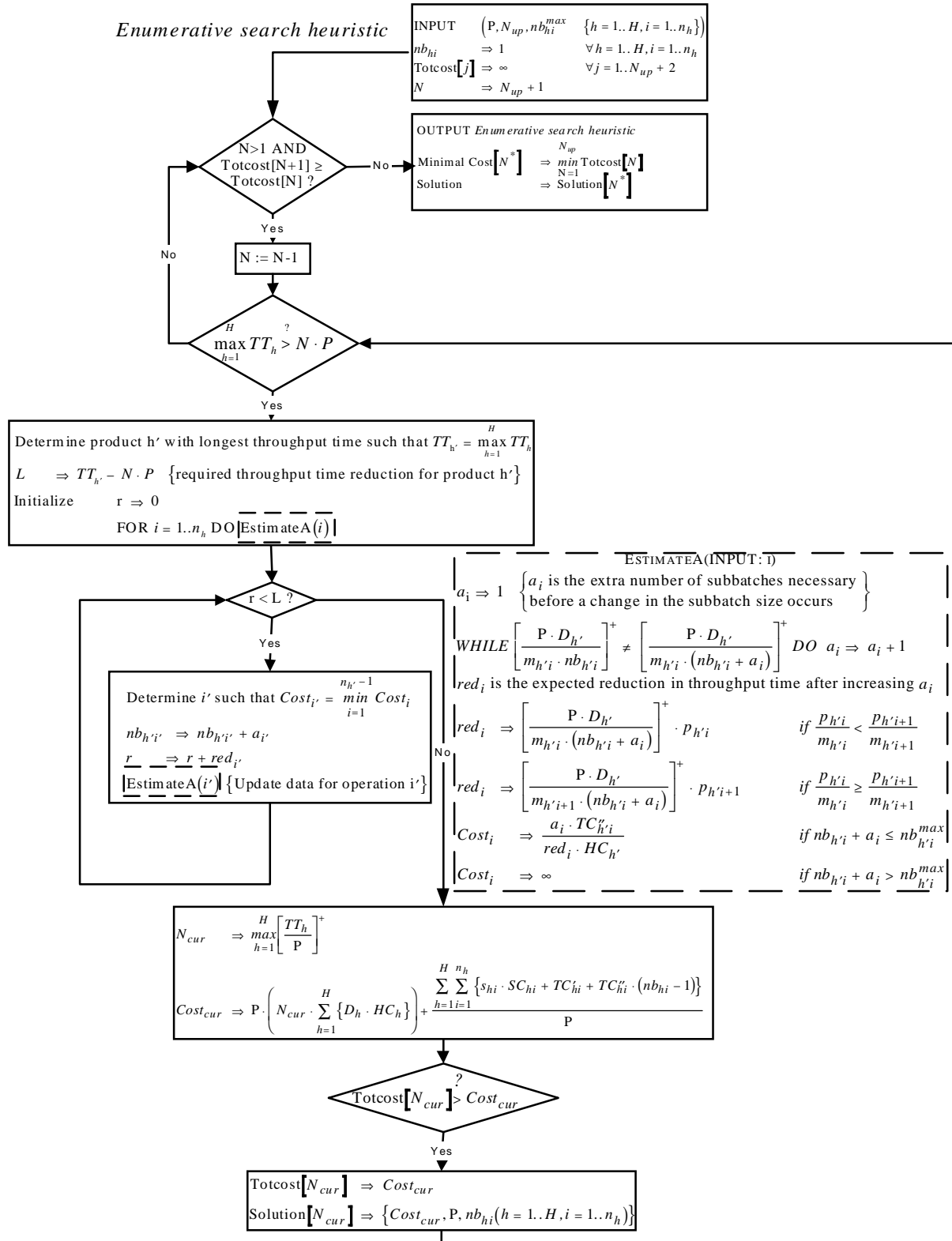

Figure 5.9 Enumerative search heuristic that finds P, N, and  $nb_{hi}$  with minimal cost

The increase in the number of subbatches for an operation causes extra transfer costs, but a throughput time reduction will eventually reduce holding costs. The ratio between both cost changes drives the selection of a suitable batching strategy. The enumerative search heuristic in itself does not prefer nested or non-nested batching strategies.

The enumerative search heuristic has been used to obtain solutions for  $P=0.002 \cdot X$ ,  $X=1..50$ . The total cost curve for successive values of P in the example problem of Section § 5.5.1 is presented in Figure 5.10. Note that the solutions are approximations of the optimal solution, and the distance to this (unknown) optimal solution may vary for successive values of P. The symbols that we use in the figure to indicate a solution denote the number of stages N for which the minimum total cost was obtained. For small values of P, solutions with a higher number of stages are dominant, but if P increases, N decreases.

The best solution obtained is for  $P=0.044$  years with  $N=2$  and a total cost of 1237.5. The batching strategy is variable and not specifically nested. The values of  $nb_{hi}$  are presented as  $nb[h=1, i=1-9; h=2, i=1-8]$ . The best solution has  $nb[3,3,3,4,4,3,3,3,1; 3,3,3,4,3,3,4,1]$ . Note that we only have applied a maximum number of subbatches at the last operation of a product.

The solution found with the enumerative search heuristic is an improvement over the best solution found with an equal number of subbatches strategy. The latter was shown in Figure 5.8 ( $P=0.028$ ,  $N=3$ ,  $nb_{hi}=2 \forall h,i$ , total cost = 1274). The difference in total cost between both solution is only 3%, but the difference in period length is more than 50%, i.e. an increase from less than 8 days to more than 11 days!

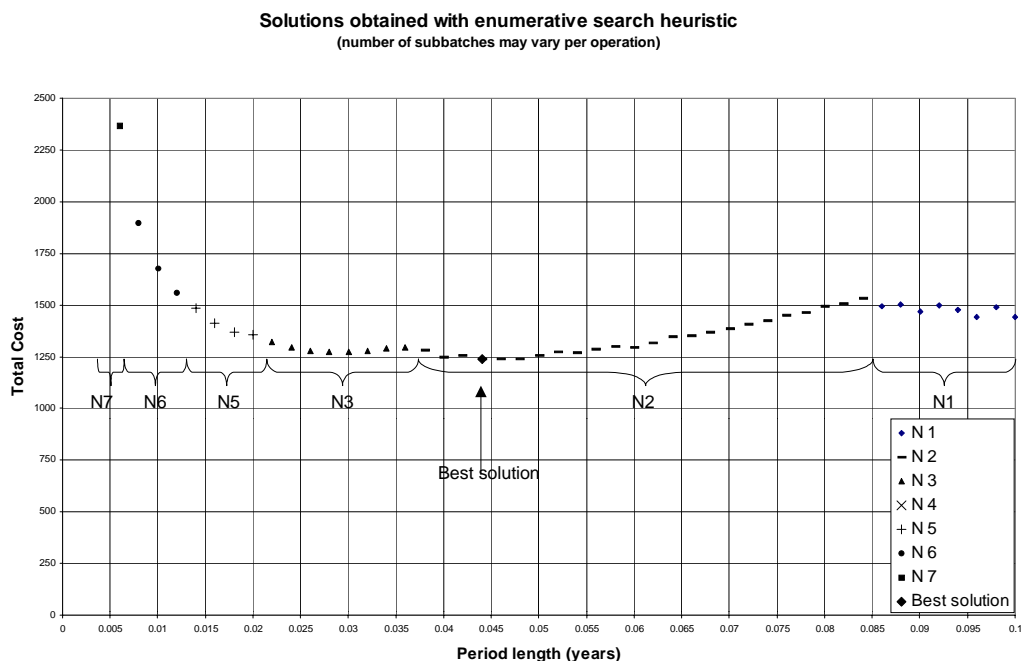

**Figure 5.10** Cost of solutions obtained with enumerative search heuristic

The cost difference between an equal number of subbatches strategy and a variable batching strategy is not high for the example problem of Section § 5.5.1. Note however, that the characteristics of the example, such as identical processing times per operation of a product, almost equal sized product throughput times, few products, and equal transfer costs for all operations, lead to a quite positive impression of the performance of an equal number of subbatches strategy. The results of this strategy in terms of total costs would deteriorate quickly if one or more of these characteristics would change.

We can conclude from Figure 5.10 that (in the example problem) the total cost function is not very sensitive to an increase in the period length, as long as a variable batching strategy is allowed and  $P$  is not too small. For small period lengths, the total cost function is very sensitive to a change of  $P$ . Therefore, the determination of the number of subbatches per operation should get careful attention in a solution approach for configuring a PBC system.

### § 5.5.3 Solution approach for the complete model: progressive search heuristic

The enumerative search heuristic finds an approximate solution for the model (11) only for a given period length  $P$ , which is input to the heuristic. The solution approach does therefore not treat the complete model, which includes the determination of a period length  $P$ . From the discussion on related problems in Appendix D and on the cost structure of the model in Section § 5.5.1, we know that trying to find an optimal solution for the complete model is not realistic. Restricting the search to an equal number of subbatches strategy may result in a good approximation, but this depends strongly on the characteristics of the input to the model. Applying an enumerative search for all possible values of  $P$  is computationally unattractive, inefficient, and also not necessary as the total cost curve is quite flat over a broad range of  $P$ -values. Hence, we strive to develop a solution approach that finds both a period length  $P$ , a number of stages  $N$ , and a batching strategy  $nb_{hi} \forall h, i$ . This (heuristic) solution approach should have a performance which is less sensitive to changes in the input parameters, and which is less time consuming than complete enumeration.

#### *Progressive search heuristic*

The *progressive search heuristic* finds a solution for the complete model (11) of determining  $P$  and  $nb_{hi}$ . It calculates the required number of stages  $N$  and the resulting costs from the value of these decision variables. The heuristic sets the minimum period length and maximum number of stages at initial values that take the available capacity into account. It applies the enumerative search heuristic for specific values of  $P$  in order to find suitable values for  $nb_{hi}$ . These values of  $nb_{hi}$  are used to determine a better approximation of the best value for period length  $P$ . The heuristic iterates between these two main parts until no further improvements are made, as is illustrated in Figure 5.11. We describe the heuristic in detail in Appendix E. There we will also pay attention to the application of the heuristic on the example problem.

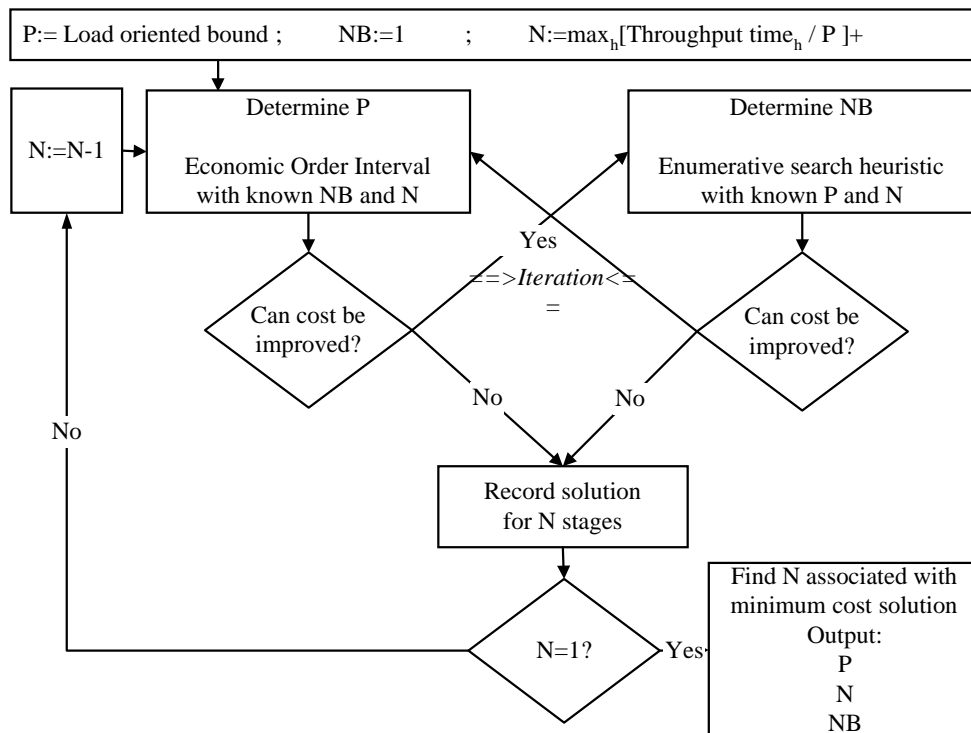

**Figure 5.11 Structure of progressive search heuristic (details in Appendix D)**

Remark that the progressive search heuristics uses an economic order interval determination approach to determine the optimal period length for given values of  $N$  and  $NB$ . The proposed period length will probably be higher than the one used in determining the batching policy  $NB$  and number of stages  $N$  that served as input. Therefore, the new  $P$  might increase the throughput time  $TT_h$ . If we observe such an increase, we will try to find a larger number of subbatches at a critical operation. The increase in the number of subbatches leads to an increase in the optimal period length, as we know from our analysis in Figure 5.7a. We have to return to our period length determination model in order to accomplish for this tendency. The iteration results in a continuously increasing number of subbatches for increasing period lengths. However, it only decides on a further increase of either of the decision variables if it results in lower expected costs.

## § 5.6 Comparing the heuristics: an exhaustive search heuristic

We have applied both heuristics to find a solution for the example problem of Section § 5.5.1. Table 5.3 presents the results of both heuristics. We see that the progressive search heuristic finds a very good approximation of the best solution found in the enumerative search heuristic. The efficiency of the progressive search heuristic was much better, as it took considerably less time to find this solution. The question rises if this result is specific for the example problem. Therefore, we want to compare the performance of both heuristics more extensively. Generally, we would like to use an optimal solution as a benchmark criterion. However, we have no technique available to find such an optimal solution for the problems we solve, hence we developed an improved heuristic solution procedure, denoted as the *exhaustive search heuristic*.

	<i>progressive search heuristic</i>	<i>enumerative search heuristic</i>
Total cost	1255	1237.5
N	2	2
$nb_{hi}$	(4,4,3,3,3,3,3,3,1; 4,4,4,4,3,3,3,1)	(3,3,3,4,4,3,3,3,1; 3,3,3,4,3,3,4,1)
P	0.04263	0.044

**Table 5.3 Solutions of heuristics for example problem**

The *exhaustive search heuristic* performs a very comprehensive search for a variable subbatch strategy for the values of P found by respectively the enumerative search and the progressive search heuristic. After each increase in a  $nb_{hi}$ , i.e. one of the operations is divided into one more subbatch, the *exhaustive search heuristic recalculates* the effect on the expected throughput time. Note that the enumerative and progressive search heuristics both *estimate* the effect on the throughput time, as a recalculation is very time consuming. The resulting solution consists of the same period length as at least one of the other heuristics had proposed, but generally a different batching strategy. The cost of this solution is used as a benchmark for the enumerative and progressive search heuristic.

### *Performance of heuristics*

We constructed 200 problems that were solved by the three heuristics. Each heuristic finds a period length P, a number of stages N, a subbatch strategy NB, and the associated total costs. The data from the illustrative example of § 5.5.1 was used as input for the random procedure that determines values for set-up and processing times of the operations. Processing times were negative exponentially distributed with means as described in § 5.5.1. Set-up times were normally distributed with means as described (resp. 15 and 12 hours per set-up) and standard deviations equal to  $\frac{1}{2}$  its mean. The load oriented lowerbound for P had to be less than four weeks.

We first applied the progressive search heuristic, starting with P identical to the load oriented lowerbound and NB equal to 1.

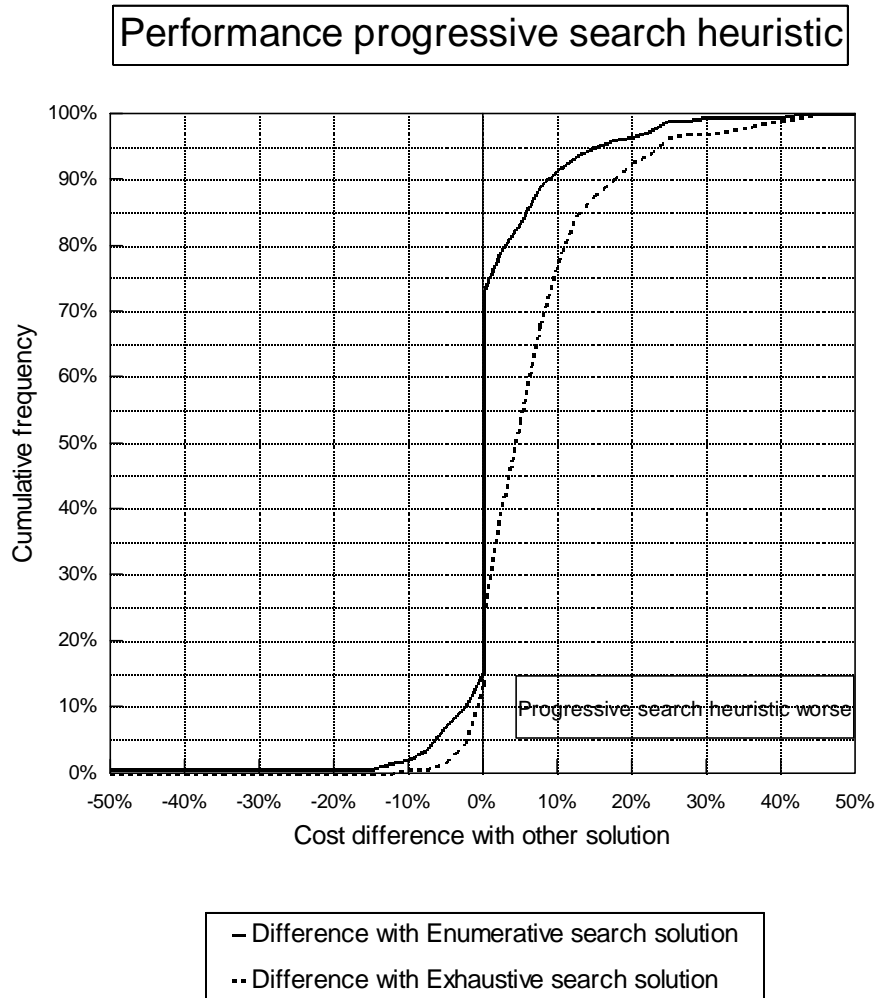

**Figure 5.12 Performance progressive search heuristic**

Cost difference of progressive search to other solution	Enumerative	Enumerative Cumulative	Exhaustive	Exhaustive Cumulative
$x \leq -7\frac{1}{2} \%$	3.5%	3.5%	0.5%	0.5%
$-7\frac{1}{2} \% < x \leq -5 \%$	3.5%	7.0%	1.0%	1.5%
$-5 \% < x \leq -2\frac{1}{2} \%$	3.0%	10.0%	3.0%	4.5%
$-2\frac{1}{2} \% < x < 0 \%$	5.5%	15.5%	9.0%	13.5%
$x = 0 \%$	57.5%	73.0%	10.5%	24.0%
$0 \% < x \leq 2\frac{1}{2} \%$	6.5%	79.5%	16.5%	40.5%
$2\frac{1}{2} \% < x \leq 5 \%$	4.0%	83.5%	13.0%	53.5%
$5 \% < x \leq 7\frac{1}{2} \%$	5.5%	89.0%	14.5%	68.0%
$7\frac{1}{2} \% < x \leq 10 \%$	2.5%	91.5%	9.5%	77.5%
$x > 10 \%$	8.5%	100.0%	22.5%	100.0%

**Table 5.4 Performance of progressive search heuristic**

Next, we applied the enumerative search heuristic. We considered a broad range of possible values for the period length  $P$ . The centre of the range was the  $P$  value such as determined by the progressive search heuristic. The lower range value was 90% below this value, with a minimum at the load oriented lowerbound. We chose the range to be symmetrical around the progressive search solution, so the upper range level could be calculated. The enumerative search heuristic was applied 80 times at equally distanced  $P$  values. For each  $P$ , it determined a suitable batching strategy, a number of stages  $N$ , and the total costs of this configuration.

Finally, we applied the exhaustive search for both values of  $P$  found.

The results of the experiments are presented both in Figure 5.12 and in Table 5.4. Figure 5.12 shows the cumulative distribution functions of the performance of the progressive search heuristic in terms of cost difference with either the enumerative search heuristic or the exhaustive search heuristic. The function that describes the difference with the enumerative search heuristic shows that 73% of the solutions of the progressive search heuristic had an identical or even better cost performance than the solutions of the enumerative search heuristic.

Table 5.4 shows that 15.5% of the progressive search solutions had lower cost than the enumerative search solutions. Remark that the progressive search heuristic internally applies the enumerative search heuristic in order to improve the batching strategy that it uses! 57.5% of the solutions were identical and only 8.5% of the solutions had a total cost that was more than 10% above the cost found by the enumerative search heuristic.

The required CPU time for computing a solution was much higher for the enumerative search heuristic. The computations for the experiments showed a factor 60 difference. A solution for the progressive search heuristic was found within the smallest time measure of our computer clock (0.054 seconds). The required CPU time for the enumerative search depends on the number of steps (predetermined at 80 in our experimental design). Both the quality of the solution found and the CPU time increase with the number of steps in the heuristic. The quality of the enumerative search solution may also improve if a more precise search range is applied.

The solution of the exhaustive search heuristic was meant to function as an indication of the optimal solution. We see from Figure 5.12 that the performance of the progressive search heuristic with respect to this solution is considerably smaller. 76% of the solutions found by the progressive search heuristic were improved. 22.5% of the solutions had a total cost that was more than 10% above the cost found by the exhaustive search heuristic.

However, a remarkable fact can be seen. In 13.5% of the experiments, the progressive search heuristic performed better than the exhaustive search heuristic and 10.5% of the cases the result could not be improved. The explanation for this behaviour is that the exhaustive search is a greedy algorithm. It applies a depth first search in the solution tree and computes the

effect on the throughput time after each modification in the subbatch strategy. However, the heuristic will never trace back in the solution tree: an increase in the number of subbatches for a specific operation early in the search process will not be reconsidered later in the search process of the heuristic. A complete enumeration of the solution tree (i.e. of all possible subbatch strategies) would identify the optimal solution, but such a search is unrealistic. We conclude that the exhaustive search heuristic has selected in 13.5% of the cases a branch of the solution tree that seemed profitable but proved to be less fortunate and successful.

Further study revealed that the cost reduction obtained by the exhaustive search heuristic comes from a different subbatch strategy. In 92% of the experiments, the exhaustive search heuristic chose the same period length as the progressive search heuristic and only 8% resulted in a higher period length. The enumerative search heuristic chose in 17% of the experiments a higher period length and 83% of the cases resulted in an identical advice on the period length. The difference between these 8% and 17% leads to the conclusion that in case of a different advice of the two heuristics the exhaustive search heuristic chooses in more than 50% of the cases for the period length advised by the progressive search heuristic.

We conclude that the progressive search heuristic shows a high performance compared to the time consuming enumerative search heuristic. The distance to the lowest cost solution found by the exhaustive search heuristic can be considerable, but in 92% of the cases the period length that was found by the progressive search heuristic remains unchanged in the best solution found. Reconsidering the subbatch strategy therefore will improve the performance of the progressive search heuristic with respect to cost. The advice on the period length  $P$  and the number of stages  $N$  can be considered good.

## § 5.7 Conclusions

We have developed a new approach for the determination of a suitable configuration of a PBC system. This configuration consists of a period length  $P$ , a number of stages  $N$ , and a variable subbatch strategy. The mathematical model that masters this approach allows for overlapping operations in determining  $P$ . The formulation of the minimal period length in our model is more exact than existing modelling approaches that include overlapping operations, which are all based on the initial work of Szendrovits (1975) (see Appendix D).

First, we developed a detailed decoupled period determination approach, which assumes that the allocation of operations to the stages and machines is known in advance. This approach yields some general restrictions on the length of  $P$ , given a number of stages  $N$ .

We have integrated the detailed decoupled period determination approach with an economic approach to period determination. This integrated approach is denoted as a detailed economic period determination approach. We distinguish echelon holding costs, set-up costs and

transfer costs in our integral model and apply an economical cost perspective in determining a period length and a transfer batch strategy. Hence, a trade-off is made between manufacturing throughput time (holding costs) and frequency of replanning (set-up and transfer costs).

The integrated approach relaxes the assumption that the allocation of operations to stages is known in advance. This causes the number of stages  $N$  to become a model variable instead of a parameter:  $N$  is a direct consequence of the maximum throughput time that results from the chosen period length and subbatch strategy. The approach has been worked out into two mathematical models: a model with an identical number of subbatches per product and a model that allows the number of subbatches per operation to vary.

Using the same number of subbatches for all operations and all products results in a system that is very transparent and easy to use, but may also lead to unnecessary reducing throughput times of products without any effect on the required number of stages. In a PBC system, overlapping production should be used only for products with throughput times longer than the available time in a stage. As we not have defined the contents of the stages in these mathematical models, we apply a variable number of subbatches only if it helps to reduce the total manufacturing throughput time  $N \cdot P$  and hence helps to minimize total cost.

Variable subbatch policies can be distinguished in non-nested, nested and powered nested policies. Non-nested policies result in a smaller number of subbatches at a following operation. This may lead to extra product waiting time compared with nested policies. Nested policies may lead to extra intermediate machine waiting time.

We developed two search heuristics that are able to determine a variable batching strategy, the enumerative and progressive search heuristic. The enumerative search heuristic finds a suitable subbatch strategy for a given period length  $P$ . Tests with the enumerative search heuristic showed that a varying number of subbatches strategy produces a rather flat total cost function for various values of the period length. This indicates that as long as one uses a high quality search algorithm for the various numbers of subbatches per operation, the total cost is not very sensitive for changes in the period length. We also showed that if the (allowed maximum) number of subbatches increases, the optimal period length tends to increase.

The progressive search heuristic finds a solution both for the period length  $P$  and the various numbers of subbatches  $nb_{hi}$ . The progressive search heuristic was shown to produce a good approximation of the best solution that we could find for a large set of problems. Especially the quality of the period length determination was high.

Do these results mean that we can apply the progressive search heuristic in PBC system design? In order to answer this question, we should reconsider the various assumptions that we made in the underlying model. First, we assumed that costs can be decomposed into echelon holding costs, set-up costs, and transfer costs. The model enables a trade-off between manufacturing throughput time (holding costs) and frequency of replanning (set-up and

transfer costs). Both period length and subbatch strategy strongly influence these costs. However, the effect of variety and uncertainty in volume and mix on these costs is ignored.

Furthermore, we assumed that the allocation of operations to the stages was not known when we determined the period length, batching strategy, and the number of stages. This approach results in multi-phased PBC systems, as the moment of release of work to the stages is not synchronous. We need a better understanding of the relationship between the PBC design factors in single-stage systems before applying the heuristic to the design of a PBC system. Chapter Six will determine the effect of stochastic fluctuations on PBC performance. It uses simulation to evaluate this performance. Chapter Seven will examine the applicability of the progressive search heuristic for finding a PBC configuration for the simulated situations.

---

## Chapter 6 Modelling the trade-off between N and P

This chapter treats the important trade-off between the length of a period  $P$  and the number of periods  $N$  in a basic unicycle period batch control system. Chapter Four has discussed the attention literature pays to the possibility of shortening the total manufacturing lead time  $T$  through decreasing both  $N$  and  $P$ . Chapter Five has described methods to determine suitable values for  $P$ ,  $N$ , and hence of  $T$ . Chapter Six will show that there remains an important trade-off between  $N$  and  $P$  if the total manufacturing lead time  $T$  is not affected.

Chapter Four has argued that the complexity of the co-ordination of the manufacturing system has to be taken into account when determining  $N$ . A large number of stages might result in a decomposition of the manufacturing system where each cell is decoupled from other cells using the stage definition. Thus, the co-ordination between the cells is accomplished using the PBC system. A smaller number of stages might result in smaller throughput times, as the stage with the longest product throughput time determines the minimum period length  $P$  and hence the minimum throughput time  $T=N \cdot P$  of the PBC system.

Chapter Four also discussed the determination of  $P$ . We have mentioned some problems, such as the start/finish effect, the set-up time effect, and the use of overlapping production. Chapter Five modelled the effect of overlapping production in order to determine a minimum period length. A mathematical model was developed that helps to determine the length of a period and the application of overlapping production, based on a trade-off of the costs incurred.

The results of Chapter Four and Five provide insight in the factors that have to be taken into account when determining  $N$  and  $P$ . However, the mathematical model for determining  $P$  in Chapter Five considers only a small number of relevant factors that influence the size of  $N$ . It considers the maximum throughput time of a product for a given overlapping production policy, and determines  $N$  as the smallest integral number of periods in which this product can be produced. It assumes that all products can be produced within this number of stages. The decomposition of the manufacturing system into these stages is not worked out and hence no attention is paid to resource interference problems, avoidance of subbatches between cells or stages, required co-ordination between cells, and so on. Furthermore, it assumes a multi-phased PBC system, as each operation can start immediately after the work has arrived. Hence, start/finish losses have not been taken into account.

Chapter Six reconsiders the relationship between the determination of the number of stages and the period length in a PBC system. Section § 6.1 studies the effect of simultaneously varying  $N$  and  $P$  under the condition of a constant manufacturing throughput time  $T$ . In PBC design, an important trade-off has to be made between  $N$  and  $P$ . The relevant factors in this trade-off are identified through a table of benefits that we expect to occur if one chooses for either a PBC system with small  $N$  and large  $P$  or a system with large  $N$  and small  $P$ . We also present some anomalous effects that might accompany such a redesign of a PBC system.

In order to evaluate the effect of varying N and P in period batch control, we develop a simulation model, simulate a cellular manufacturing system and measure its performance for various configurations of the basic unicycle period batch control system. Section § 6.2 pays attention to design of the simulation model. First, it describes the performance measures that will be used in the evaluation of the various configurations of the PBC system. Next, it discusses the simulation model and simulated cellular manufacturing system. We distinguish two production situations. Section § 6.3 presents the results of varying N and P on the performance in production situation I. Section § 6.4 presents these results for a second production situation with more routing variety. Section § 6.5 presents the final conclusions.

### § 6.1 Trade-off between N small & P large and N large & P small

The literature review of Chapter Four has revealed that both a reduction of N and a reduction of P will result in a decrease of stocks, work in progress, and investments, and an increase of flexibility and responsiveness to the customer. However, a reduction in either N or P results in a reduction in the manufacturing throughput time T. All benefits mentioned so far are also known from literature as results of a throughput time reduction, as shown in Figure 6.1. Therefore, the question rises to what extent a change in the configuration of a PBC system in itself has an effect on the performance criteria that are mentioned in literature.

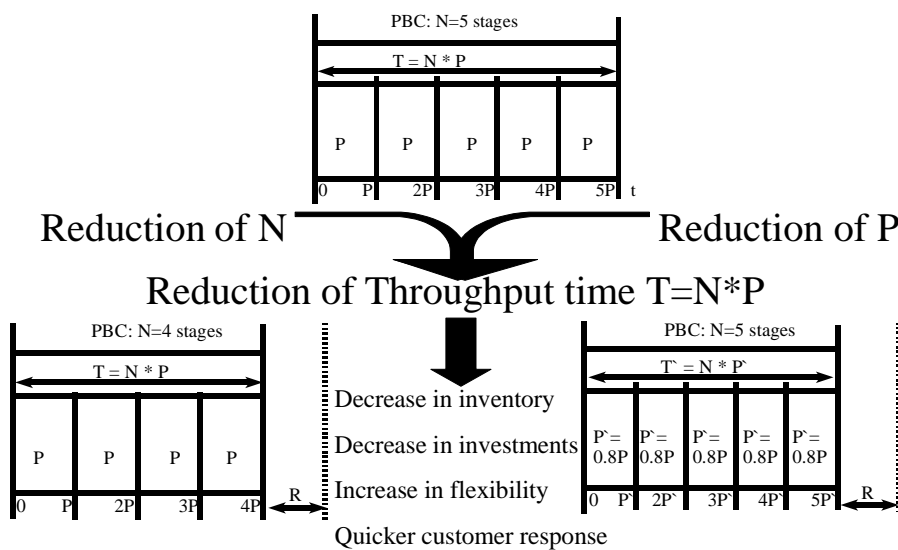

**Figure 6.1 Effects of PBC configuration change through reduction of T**

Literature on PBC does not give insight in the trade-off between systems with identical throughput time. To evaluate this trade-off, we consider various configurations of N and P with N times P constant. The benefits of the manufacturing throughput time reduction will therefore not perturb this evaluation, as depicted in Figure 6.2. We further assume all other things being equal, such as the cell scheduling system, routings, and so on. Under these conditions, we want to determine the relevant factors in choosing the relative size of N and P.

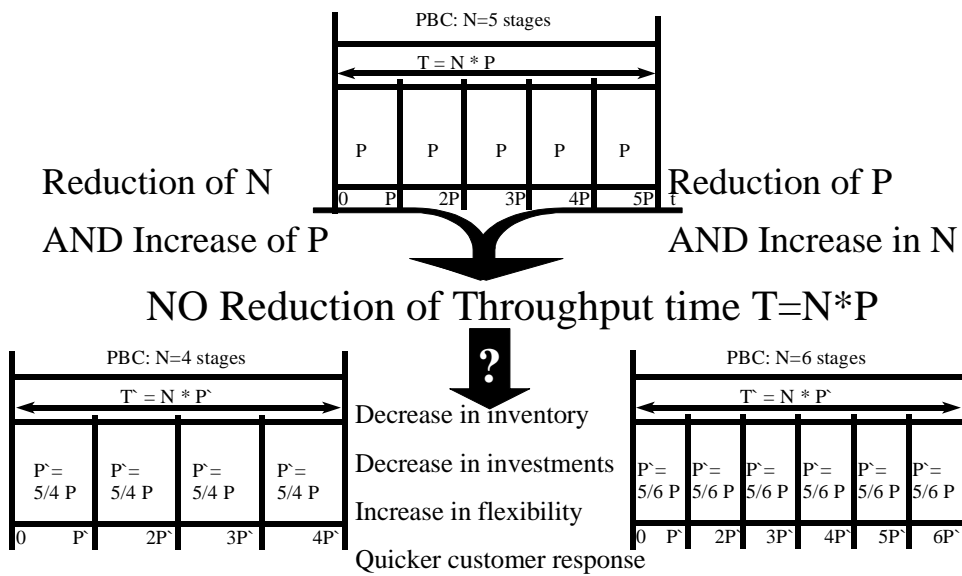

**Figure 6.2 Trade-off between PBC configurations with identical throughput time**

Figure 6.3 and Figure 6.4 further illustrate the situations that we distinguish. Figure 6.3 shows a PBC system configuration with  $N=2$  and  $P=1\frac{1}{2}$  (N small, P large). It has only two stage decoupling stocks and several sequentially dependent operations per stage. Figure 6.4 has  $N=6$  and  $P=\frac{1}{2}$  (N large, P small). The number of operations per stage is much smaller, as well as the relationships between operations within a stage. Both systems have  $T=N\cdot P=3$ .

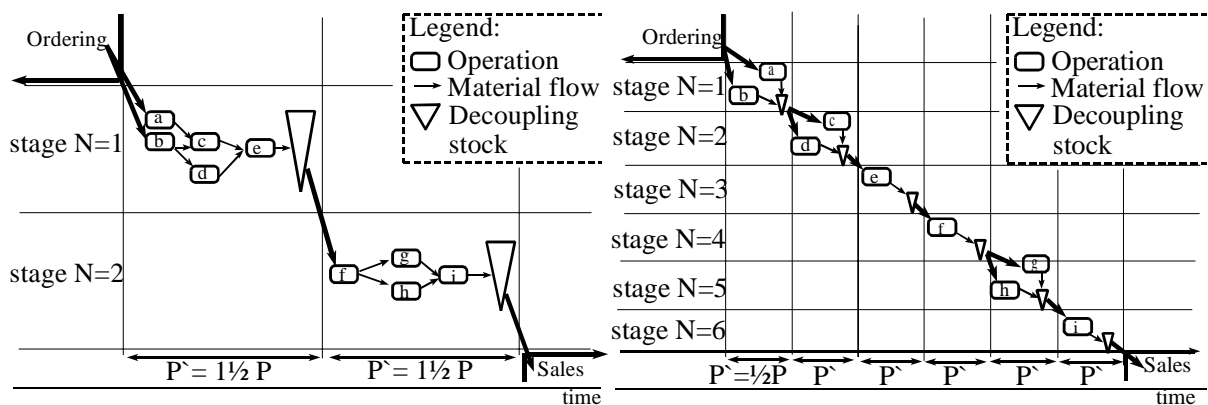

**Figure 6.3  $N=2, P=1\frac{1}{2}$  (N small & P large)**

**Figure 6.4  $N=6, P=\frac{1}{2}$  (N large & P small)**

We describe the expected effects of varying the relative size of N and P for the system, and make a distinction between system input, output, process and control. Table 6.1 presents the results of this evaluation. The left side of the table describes the expected positive effects in case PBC systems use a small number of stages with a relatively large period length. The same effects could be viewed as negative effects at the right side of the table. We have restricted ourselves to describing the expected positive effects at both sides of the table.

Factor		
Input	Increased volume and mix flexibility	Later release of material in the process through just-in-time delivery
Process	Less sensitive to long processing times Less occurrence of start/finish losses Less set-up time losses More attractive work packages	Higher utilization of bottlenecks Smaller start/finish losses Increased learning effects Less overlapping production effort in a stage
Control	Less programming efforts	Better progress control Better synchronization Easier co-ordination of subcontracting Easier co-ordination of shared resources Easier sequential co-ordination between cells
Output	Less forecasting effort Levelled demand variations per period	Less finished stock Smaller customer order lead time

**Table 6.1 Expected positive effects of (N small, P large) or (N large, P small), T constant**

In Figure 6.1, we already mentioned various positive effects of a *decrease* in P. There are also some positive effects that we expect for the organization and utilization of the process in case P *increases*. In Chapter Four, we introduced the start/finish effect and set-up time effect within PBC. We showed that an increase in P reduces both effects and as a consequence enables a higher utilization of the various processes.

However, the conclusions of Chapter Four do only hold if the number of operations that have to be performed within a stage remains constant. If an increase in P is combined with a decrease in N, the operations in the eliminated stage(s) have to be reallocated to other stages. This redistribution may have negative effects on the start/finish losses, volume and mix flexibility, and co-ordination efforts. Some of the expected benefits at the left hand side of Table 6.1 therefore depend on the quality of the redistribution of the operations, i.e., the new contents of the stages.

The frequency of input in the system decreases if N becomes smaller and P higher. Figure 6.5 shows the consequence of a period length increase from 1/2 to 1 1/2 and a number of stages reduction from 6 to 2. Material that was formerly required in the third period has now to be available at the start of the first period, and so on. The early shipment causes an increase in the investment in working capital and inventory within the system.

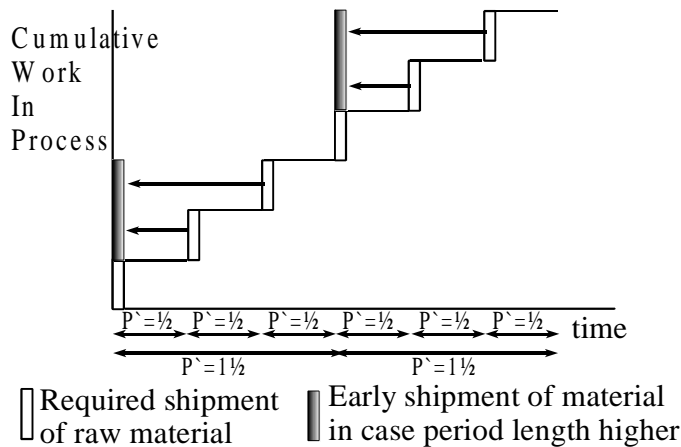

**Figure 6.5 Increase of Work In Progress if  $P \uparrow$  and  $N \downarrow$**

A longer period length makes it also possible to improve the selection of work for a manufacturing process. This makes it easier to balance the load within a period and hence allows an increase of the mix flexibility. The system becomes less sensitive to fluctuations in the demand for end products.

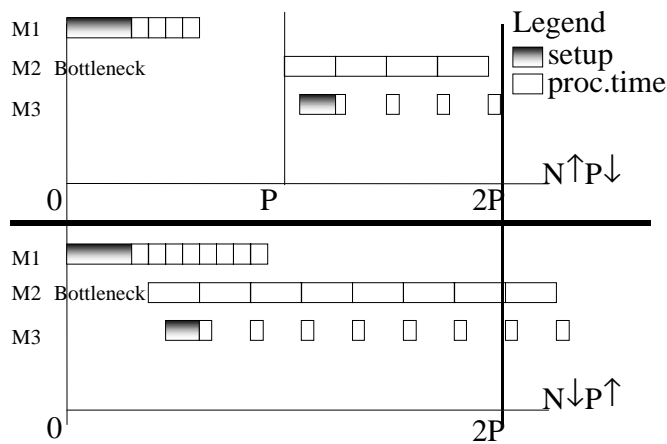

**Figure 6.6 Lower bottleneck utilization if  $N \downarrow$  and  $P \uparrow$**

We found two anomalous effects of an increase in P. The first effect is the possibly lower utilization of a bottleneck in case P increases, due to the start/finish effect. Figure 6.6 illustrates this anomalous effect. The upper side of this figure shows a situation with 2 stages. The bottleneck M2 performs the first operation in the second stage. Overlapping production is applied to finish the operation after the bottleneck within the period length P. The maximum capacity is 4 products per period P.

The lower side in Figure 6.6 shows the combination of the two stages to a new stage with a doubled period length 2P. The batch size has to increase to 8 products to realize the same output. The combination of the bottleneck with a preceding process causes a longer waiting time before the bottleneck can start (the start/finish effect), and hence it is not possible to finish the 8 products within the doubled period length.

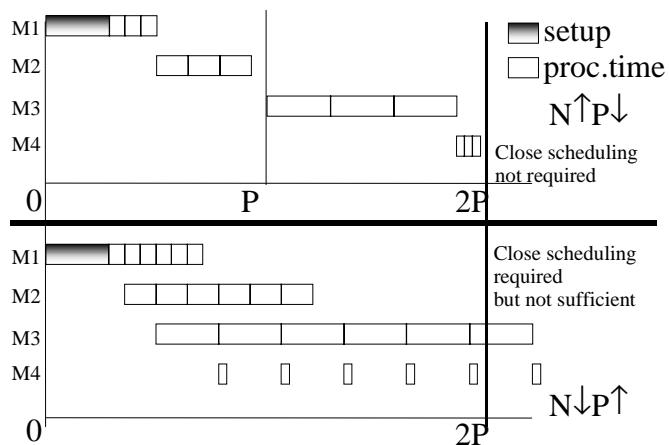

**Figure 6.7 Increase in overlapping production if  $N \downarrow$  and  $P \uparrow$**

The second remarkable effect that we found concerns the possibility of an increase in overlapping production requirements (and hence of transfer costs and co-ordination efforts) if  $P$  increases. It may even occur that the increase in  $P$  makes it necessary to apply overlapping production, but that the amount of products that can be produced in the doubled period length using overlapping production is still smaller than could be produced without overlapping production in the two periods. Figure 6.7 illustrates this anomalous effect.

In general, a larger  $P$  results in more operations per stage and more precedence relationships between these operations that have to be counted for within a period. This increases the co-ordination effort within a stage. If the usage of overlapping production is intensified, the control and co-ordination effort within a stage further increases. Note however, that the frequency of these co-ordination and control efforts decreases, as the length of the period is longer and PBC progress control takes place at the end of a period, which reduces the frequency of progress control. The increased co-ordination effort per stage is therefore combined with a reduced transparency of the planning system. An increased period length decreases the frequency of determining programs for subsequent periods. This requires less time from management, less information gathering and forecasting efforts.

Moreover, if there are subcontracting activities that can only take place after some operations in the stage have been finished, the co-ordination of these activities becomes more problematic in case  $N$  is smaller and  $P$  larger. The same holds for the use of shared resources. Increase of  $N$  makes it easier to isolate such activities or resources in a single stage. The focus of the co-ordination of such activities changes to co-ordination between the stages, and PBC accommodates this sequential co-ordination through its synchronization mechanism.

Finally, we consider the factor output of Table 6.1. PBC systems with small  $N$  and large  $P$  are less sensitive for variations in demand. Alternatively, systems with smaller periods have to invest less in finished stock and are able to deliver their customers more frequently.

## § 6.2 Design of a simulation model

For the comparative analysis of the various configurations of N and P, several modelling approaches can be used. Most studies that compare system performance for different production situations or market characteristics use simulation as the appropriate tool. See, for example, Rees, Huang and Taylor (1989), which apply Q-Gert simulation, and Yang and Jacobs (1992) and Steele, Berry and Chapman (1995), which apply discrete event simulation. Other authors apply mathematical modelling or graph theoretic analysis. See for example Ahmadi and Wurgaft (1994), Kaku and Krajewski (1995), and Lee and Posner (1997).

For our study, discrete event simulation is the most appropriate tool. This type of simulation allows more flexibility in modelling the production situation than a Q-Gert simulation analysis. Other types of simulation, such as continuous time simulation, will not result in more insight in the trade-off. Finally, the problem is too complex for a complete mathematical analysis, mainly because of the interaction that occurs between jobs at the resources and the resulting tardiness performance. Therefore, discrete event simulation is the most appropriate tool for our analysis. This section will discuss some basic modelling decisions and the characteristics of the model.

The experimental approach of our simulation study is to examine the performance of the configurations of the basic unicycle PBC system under various demand conditions, scheduling policies, and transfer batch policies. This makes it possible to evaluate if the market performance (i.e., mix and volume flexibility) and internal efficiency of the PBC system change when another configuration is applied.

### § 6.2.1 Modelling overtime in a PBC system

An important difference between simulation studies on PBC performance is the way they handle the tardiness of jobs. If a number of jobs have not been completed within a period, some studies allow that these tardy jobs are completed during the next period. As soon as they are finished, these jobs are transferred to the next stage. Therefore, the next stage has less than a period available to complete the tardy jobs of the former stage, and may not be able to benefit from the similarities in set-ups of the various jobs. Note that tardy jobs at the final stage result in a lower performance to the customer, but tardy jobs in the other stages have consequences for the production efficiency and capacity utilization. The resulting PBC system is not single phased. Steele et al. (1994, 1995, and 1997) apply this model of PBC and use mean tardiness at the *final* stage as a performance indicator in their studies.

Kaku and Krajewski (1995) model a single phased PBC system. They allow the use of overtime in order to complete the work package for *each* stage within a period. They use overtime costs as a performance indicator, which is balanced against overall inventory costs.

As we examine the basic unicycle PBC system, which is single cycle and single phased, we allow overtime work to complete all tardy jobs in each stage and hence apply the same system as Kaku and Krajewski (1995). We have to measure the amount of working hours required to finish the tardy jobs in each stage (dependability). This has to be balanced with costs, such as holding, transfer, and set-up costs. We have to gather information on the inventory costs, and the timing of its increase.

### § 6.2.2 Characteristics of the production situation in the simulation analysis

We have decided to base our simulation study on a production situation known from recent literature. We will use the cellular manufacturing production situation that is described in Steele, Berry and Chapman (1995). However, in order to perform the type of analysis that we want to do, we need to modify some characteristics of the originally described production situation. The main characteristics of the system, product structure and operations (both production operations and assembly tasks) have not been altered. The resulting production structure is denoted as *production situation I*, in order to distinguish it from the situation of Section § 6.4.

The cellular manufacturing system that we consider produces small industrial vehicles and consists of five cells. Four different part families are produced in the three fabrication cells (see Figure 6.8). Assembly of these parts is performed in two subsequent assembly cells. Every part family or product requires subsequent processing on all machines in a cell

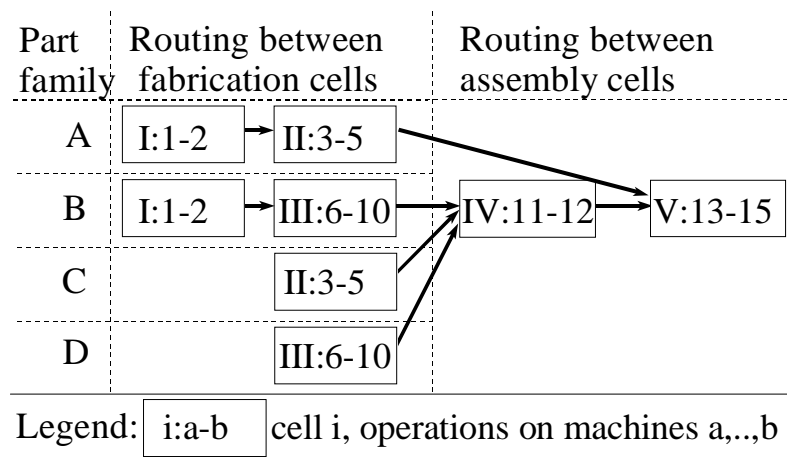

**Figure 6.8** Part routings in simulated production situation I

- Cell I is a fabrication cell and consists of only 2 machines, one for cutting operations (1), and one for finishing operations (2). All parts move from the cutting operation to the finishing operation. Finished parts are used in cell II (part family A) and III (part family B). The required input material is obtained from the raw material stock.
- Cell II is a general machining cell, consisting of 3 machines (3:press, 4:grinder and 5:machine centre). It continuously processes part family A from cell I, which is afterwards transferred to cell V. Cell II also processes a new part family C, which is required in cell IV. The input material for part family C is obtained from the raw material stock.
- Cell III is a transmission machining cell performing five operations: 6:conventional milling, 7:drilling, 8:numerically controlled milling, 9:cleaning, and 10:heat treatment. It continuously processes part family B from cell I and delivers it to cell IV. It also processes a new part family D, which again is required in cell IV. The input material for part family D is obtained from the raw material stock.
- Cell IV is a transmission subassembly cell. The main operation is 11: assembling the transmission system, which is afterwards tested (12). Items from part families B, C, and D, and a large amount of items from external suppliers are assembled into such a system. If the system works appropriately, it is transferred to cell V.
- Cell V is the final assembly cell. It consists of 13:assembly, 14:painting and 15:inspection operations. It uses the transmission system from cell IV and items from part family A as input, as well as a large amount of items from external suppliers, such as paint and all non-metal parts.

Oper.	Work station	Cel	S	Product 1				Product 2				Product 3			
				Fam	P	Fam	P	Fam	P	Fam	P	Fam	P	Fam	P
1	cutting	I	25	A	6	B	5	A	2	B	4	A	5	B	12
2	finishing	I	45	A	5	B	5	A	5	B	5	A	5	B	5
3	press	II	90	A	4	C	4	A	3	C	3	A	5	C	5
4	grinding	II	10	A	5	C	7	A	10	C	10	A	5	C	5
5	mach center	II	15	A	3	C	8	A	3	C	10	A	5	C	8
6	mill	III	10	B	6	D	6	B	6	D	6	B	6	D	6
7	drill	III	10	B	5	D	6	B	5	D	5	B	5	D	5
8	nc mill	III	40	B	6	D	6	B	5	D	5	B	6	D	6
9	cleaning	III	0	B	5	D	5	B	5	D	5	B	5	D	5
10	heat treatment	III	0	B	10	D	5	B	10	D	5	B	10	D	5
11	sub assembly	IV	20						15						
12	test	IV	10		6				6				6		
13	assembly	V	20		15				15				15		
14	paint	V	20		12				12				12		
15	inspection	V	0		10				10				10		

Fam: Parts family

S: Set-up time (minutes per set-up)

P: Processing time (minutes per unit)

**Table 6.2 Major set-up times and processing times in production situation I**

The major set-up times and mean processing times of the 15 operations are presented in Table 6.2. Note that the length of the major set-up time is independent of the product that is to be produced. All minor set-up times are zero. The processing times vary per item.

The Bill Of Material (BOM) of the products in production system I is presented in Figure 6.9. All products have the same part routings, but there is no commonality of parts, i.e., there is a one to one relationship between parts and the end product in which it is used.

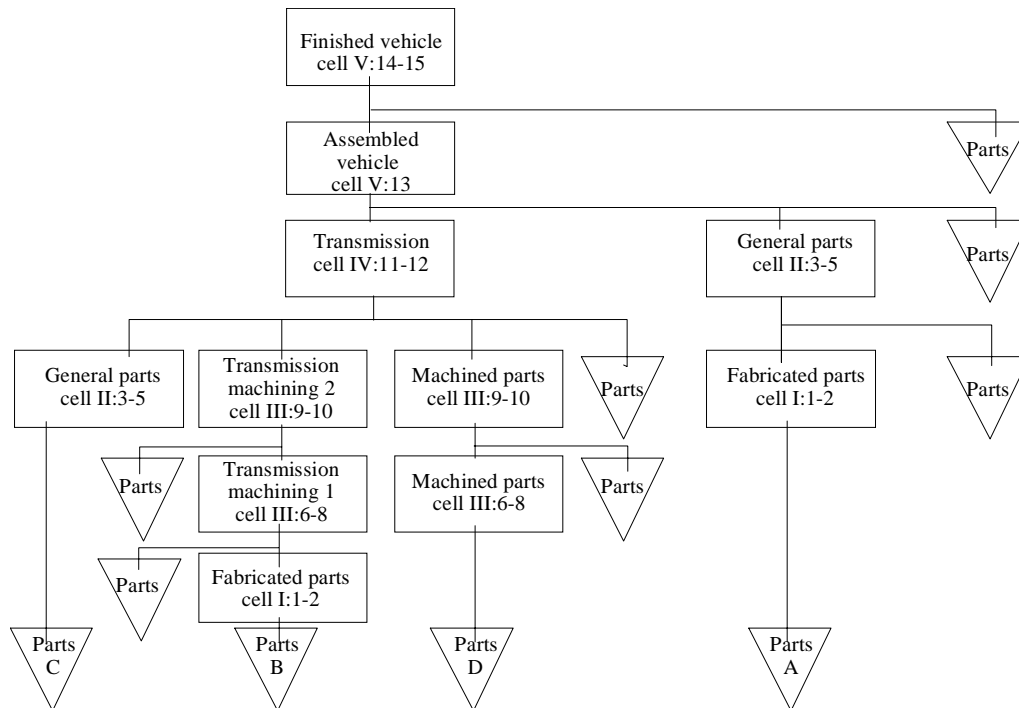

**Figure 6.9 Bill Of Material in production situation I**

### § 6.2.3 Model of Period Batch Control planning system

In order to simulate a PBC planning system, we also need input on the characteristics of the design of the PBC system. The design of the PBC system includes the determination of:

- restrictions on the order acceptance process (volume and mix restrictions)
- the number of stages N and period length P
- the allocation of operations to the various stages
- the co-ordination mechanism between cells within a stage
- the scheduling rules that may be used within the cells

We further assume that the design of the production system has been completed. This includes the design of the cells (the allocation of various resources to the cells) and the determination of the machine that has to perform a specific operation of a product.

The operation of a PBC planning system in our simulation model is described in Figure 6.10. It shows the basic entities and building blocks in the simulation model. The process starts in the upper left corner with the arrival of customer orders for the various products. Orders arrive in the system, either according to a Poisson process, i.e. the interarrival time per product type is negative exponentially distributed, or according to a constant interarrival time.

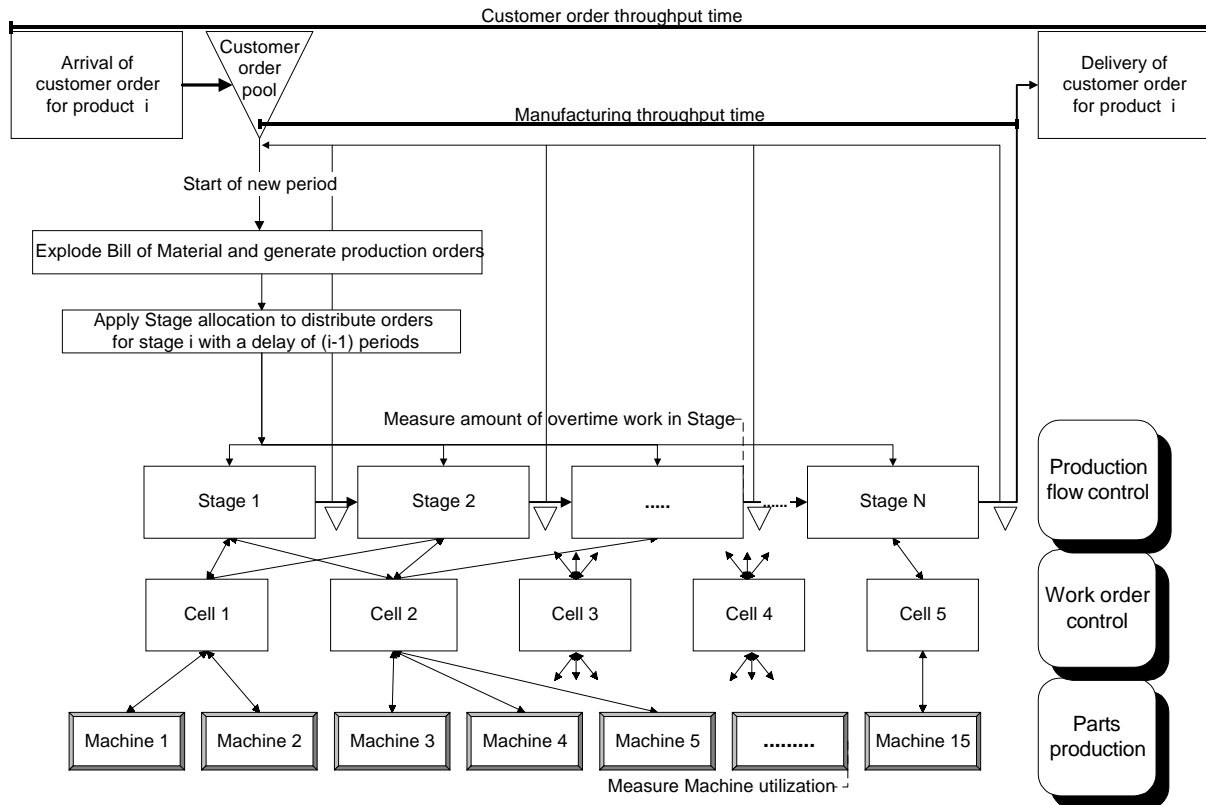

**Figure 6.10 Simulation model of a PBC planning system**

The quantity ordered is uniformly distributed between  $5 \pm$  a deviation of maximum 4 items per customer order (the parameter AfwVol). After arrival, an order is put into the customer order pool, where it waits until being released to production. At the start of a new period in the PBC system, the customer orders in the pool are released to the floor. In our simulation experiments, the mean number of products ordered during the manufacturing throughput time T is constant, and we examine the performance of the PBC system without restrictions on the mix or volume that is released per period.

If the set of customer orders for release in this period has been determined, the orders are combined into production orders for end products. The Bills Of Material (BOM's) are exploded to determine the required numbers of parts and generate production orders for parts. This explosion does not have to count for gross to net calculations, as is usually done within MRP. A simple Lot-for-Lot order quantity procedure can be applied.

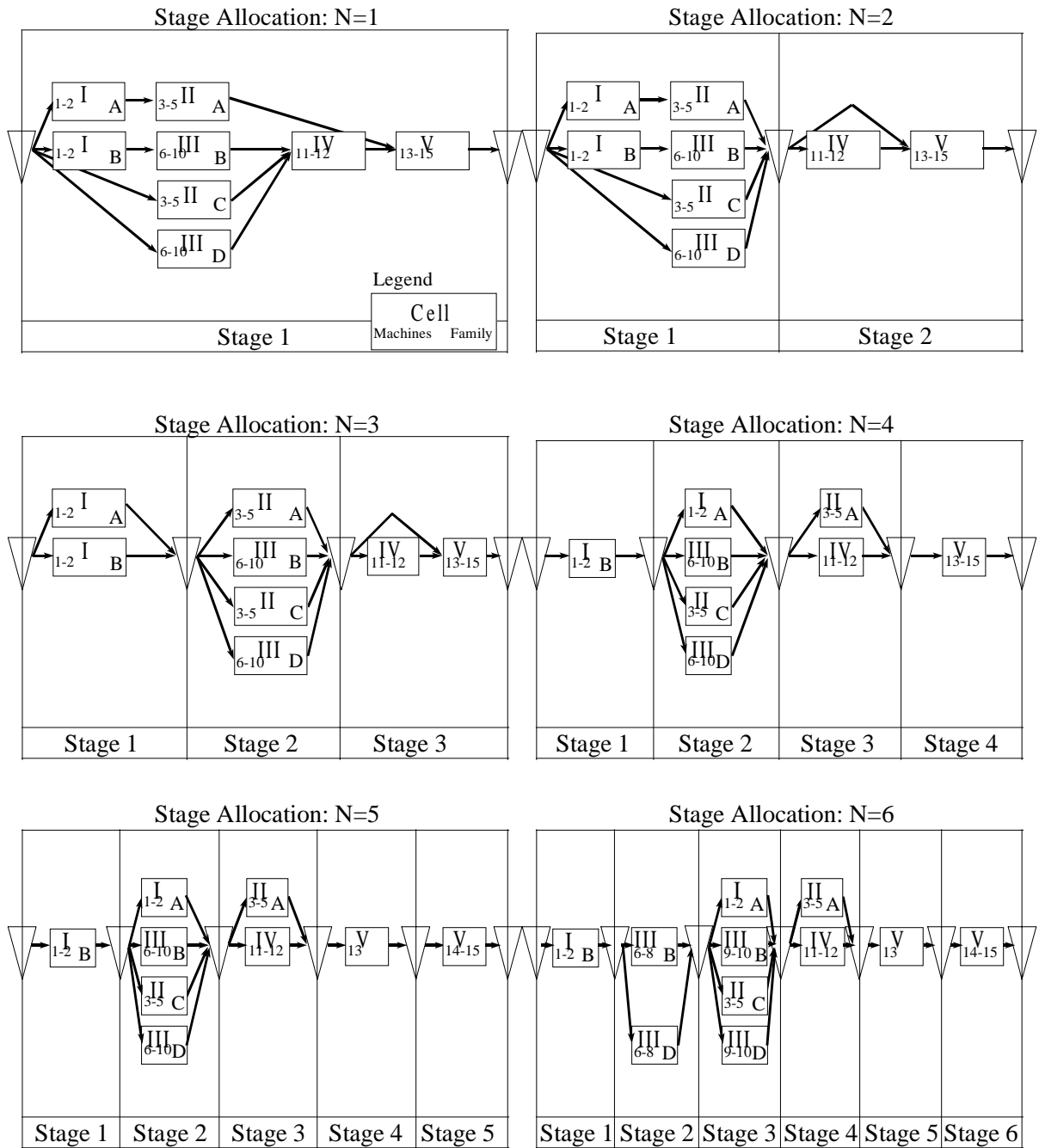

**Figure 6.11 Applied stage allocation in simulation of production situation I**

The next step is to allocate the production orders for parts to subsequent stages. Note that we do not use the standard lead time offsetting procedure that is used in MRP explosion within PBC. Instead, we apply stage allocation to determine the period in which a specific order for parts will be released to the floor. This data is not predetermined in the BOM of a product, but depends on the number of stages N and the period length P. Figure 6.11 shows the stage allocation that we applied in our experiments. This allocation is deduced from the stage allocation that was used in Steele, Berry and Chapman (1995). They tested a PBC system

with four stages. The allocation of operations to these four stages is identical to the one presented above for  $N=4$  and was based on the actual cellular manufacturing system of production situation I. Note that the allocation for  $N=4$  is not purely an allocation according to processing stage, as cells occur in more than one stage for different families. The allocations that were used for smaller  $N$  group operations that belong to the same processing stage, while the allocation for higher  $N$  distinguishes the position of high-loaded machines, such as machines 13, 10, and 3. Applying stage allocation yields a list of work orders for stages 1,...,N. The work orders for stage 1 are immediately released to this stage, but the work orders for stage 2 have to wait one period before they may be started, so work orders for stage  $j>1$  are delayed  $(j-1)$  periods before they are released to their stage. This allows an earlier stage to produce the required input material for the operations in this stage, as the synchronization mechanism of PBC requires that the inputs for work orders in a stage have to be available not earlier than at the start of the stage.

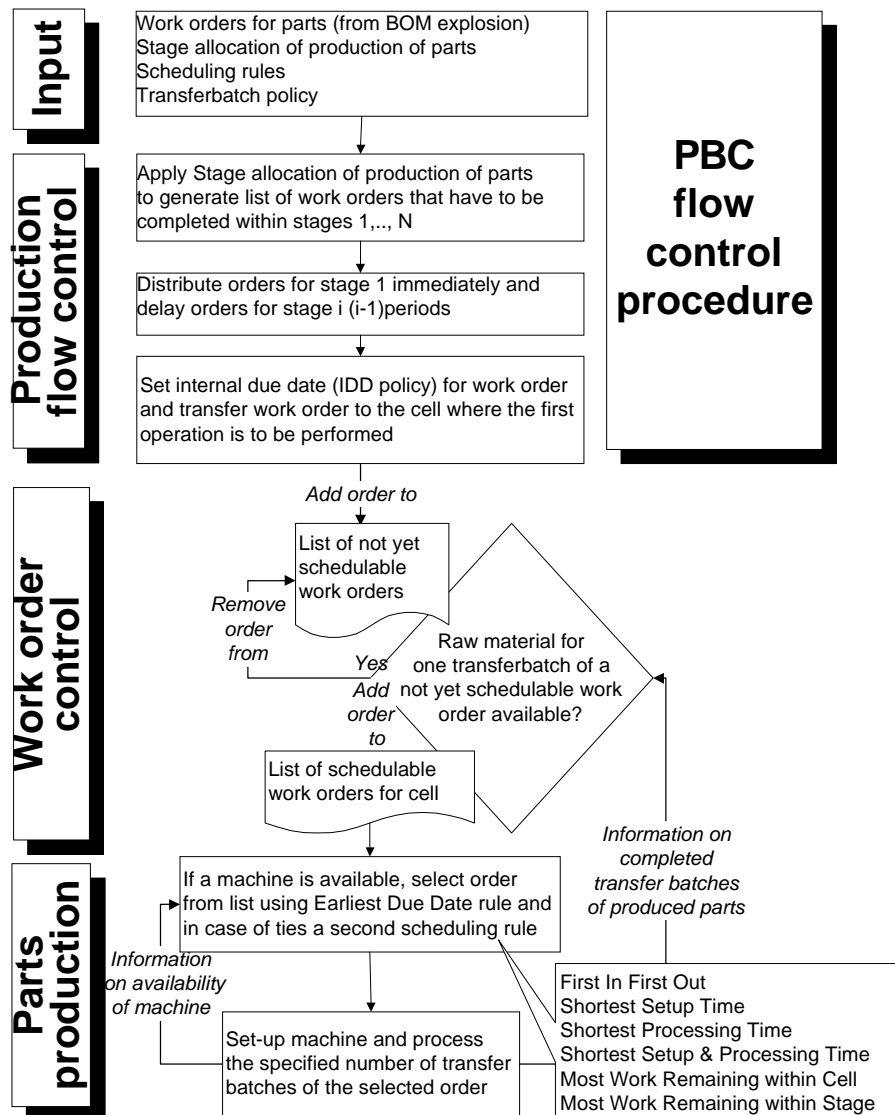

Figure 6.12 Details on flow control in PBC

Production flow control takes place at stage level. This includes control of the intercellular flow of work within a stage. We can decide to set internal due dates (IDD) for work orders that have to visit more cells within one stage. Such a decision results in different due dates of work orders. As a fixed rule, an earliest due date policy is applied at cell level to prioritize between work orders with different due dates. An internal due date setting procedure (IDD policy) that selects different due dates within a stage therefore affects the scheduling systems that are applied within the various cells. There do exist alternative possibilities for instruments at production flow control, but we have only included the IDD policy as a production flow control instrument in our simulation experiments.

The stages transfer all work orders at the start of the period to the cells that have to perform the first operations in the routings of the work orders. Note that a cell can receive work orders from various stages, and hence the cell can produce parts that are worked into end products that fulfil demand in different periods. It depends on the stage allocation method and the number of stages if this situation will occur. Section § 4.4 has discussed this phenomenon. Note also that a stage can distribute work orders to various cells. These cells may even be sequentially dependent within the stage, i.e., the work order for the first cell has to be completed before the next cell can start with its work order.

Each cell has a list of not-yet-schedulable work orders. At the start of a period, all new work orders are added to this list. If enough input material is available to start a transfer batch of this work order, the work order is transferred to the list of schedulable work orders. The cell selects an order from this list based upon the availability of the machines and the scheduling rules they apply. Figure 6.12 shows this process in detail. It also makes clear that a machine may have to wait after finishing the first transfer batch if the input material for the next transfer batch has not yet arrived.

Parts production monitors the state of the machines in the system, considers if a minor or major set-up of the machine is needed, acquires the input material for the next transfer batch, and signals the availability of a machine to the cell.

If the required operations in a stage have been performed, the material is put into the stage decoupling stock. There it awaits the start of the next period: the signal for synchronized transfer of all material to the next stage. If a stage would not have finished all operations, the remaining work is assumed to be performed in overtime. We count the amount of working hours that remains to be performed before the new period starts.

If all stages have been completed, the products are ready for delivery to the customer. The required expediting activities are not explicitly modelled.

### § 6.2.4 Simulation modelling environment

The simulation has been performed in DESIMP 1.5c (Stokking, 1996), a Discrete Event SIMulation in Pascal simulation modelling environment, developed at the University of Groningen. This environment allows us the required flexibility to add programming code in Borland Pascal 7.0. DESIMP consists of libraries with procedures and functions for simulation and reporting, and a framework to specify a discrete event process-oriented simulation model. There is a lot of experience available at our university with this simulation tool, which supports the verification of the model. The verification and validation analysis is described in Appendix F. From our verification analysis we conclude that the model behaves as we expect it to behave. From the validation analysis we conclude that the results of the simulation experiments can be used for our research purposes.

## § 6.3 Performance of PBC in production situation I

The simulation model has been used to analyse the performance of the PBC system. We are interested in the effect of varying the number of stages  $N$  while keeping the product  $T = N \cdot P$  constant. First, we discuss our experimental design in Section § 6.3.1. Section § 6.3.3 describes the methodology used to analyse the results. Section § 6.3.4 presents the results.

### § 6.3.1 Experimental design

The PBC system is tested for a constant manufacturing throughput time of 15 working days of 8 hours ( $T=7200$  minutes). These 15 days are chosen in order to generate period lengths that are comparable with the ones used in literature on the performance of PBC (e.g., Steele and Malhotra (1997), Kaku and Krajewski (1995)). The throughput time is decomposed into 1 to 6 stages,  $N=1,2,\dots,6$ , resulting in period lengths  $P$  of respectively 7200, 3600, 2400, 1800, 1440, and 1200 minutes (i.e., 15, 7.5, 5, 3.75, 3, and 2.5 days). For each of these decompositions, the appropriate allocation of operations to stages, described in Figure 6.11, has been used.

We consider some additional experimental design factors in order to evaluate the effect of  $N$  and  $P$  in various situations and compare the size of the effect of varying  $N$  with the effect of other design factors. The extra experimental design factors that we use are:

- the number of transfer batches or subbatches
- the scheduling policy used within the cells
- the effect of stage co-ordination within a stage using internal due dates
- the sensitivity to an increase or decrease in the loading of the production system
- the effect of variation in the mix of products loaded into the system

Table 6.3 summarizes the factors in our experimental design.

Factor	Values	Description
N	1,2,...,6	<b>Number of stages</b>
NrSub	1,2,...,4	<b>Number of transfer batches</b>
Policy	1,2,...,6	<b>Cell scheduling policy</b> (used if several orders have equal due date)
	(Pol2=0)	1 FIFO
	(Pol2=0)	2 SST Shortest Set-up Time
	(Pol2=1)	3 SPT Shortest Processing Time
	(Pol2=1)	4 SSPT Shortest Set-up+Processing Time
	(Pol2=0)	5 MWRC Most Work Remaining in Cell within Stage
	(Pol2=0)	6 MWRS Most Work Remaining in Stage
IDD	0, 1	<b>Stage Co-ordination: Internal Due Date setting</b>
		0 Work orders have equal internal due date: end of the period
		1 Work orders have internal due date equal to the period length P divided by the number of cells that remains to be visited within the same stage
Volume	60,75,90	<b>Number of orders</b> that arrives during T
AfwVol	0, 4	<b>Maximum deviation</b> from the mean (5) of the uniformly distributed number of products per order.

**Table 6.3 Experimental design factors**

This experimental design results in  $6 \cdot 4 \cdot 6 \cdot 2 \cdot 3 \cdot 2 = 1728$  different experiments. Half of these experiments (AfwVol=0) are purely deterministic, as each period T an identical number of products arrives in the system. For these deterministic experiments we have performed one replication and a run length of 4 periods of length T. The other experiments (AfwVol=4) have been replicated 25 times, each with a run length of 20 periods of length T (so  $20 \cdot N$  periods of length P). The start-up period was for all experiments (N+3) periods. The mean values of relevant performance measures could be calculated with sufficient accurateness in a random selection of these experiments. See Appendix F for more details on the experimental design.

We have determined the number of orders per period of length T at 75, using the data from Table 6.2. The machines that are heavily loaded will have a utilization of 60-80%. Which machine will be bottleneck depends on the period length P, as this influences the number of set-ups. Machine 13 will generally be the bottleneck, but in case N=6, P=1200, machine 3 has the highest utilization.

As we want to test the sensitivity of a PBC configuration for increased and decreased loads, we have determined the consequences if the load is increased to 90 orders per period T. All machine utilization percentages remain smaller than 100%, and machine 13 is bottleneck. If the load is decreased to 60 orders, utilization decreases to 40-80%, and the bottleneck is either machine 10, 13 or 3 for different values of N. Table 6.4 shows the expected utilization of the machines for a given number of stages N at a volume of 75 orders per period T.

Machine	Number of stages:	1	2	3	4	5	6
1		61%	63%	65%	67%	69%	72%
2		56%	60%	63%	67%	71%	75%
3		49%	57%	64%	72%	79%	87%
4		74%	75%	75%	76%	77%	78%
5		65%	67%	68%	69%	70%	72%
6		63%	64%	65%	66%	67%	68%
7		55%	55%	56%	57%	58%	59%
8		62%	66%	69%	72%	76%	79%
9		52%	52%	52%	52%	52%	52%
10		78%	78%	78%	78%	78%	78%
11		69%	69%	70%	71%	72%	73%
12		32%	32%	33%	33%	33%	34%
13		79%	80%	81%	81%	82%	83%
14		63%	64%	65%	66%	67%	68%
15		52%	52%	52%	52%	52%	52%

**Table 6.4 Machine utilization; volume 75 orders per period T**

### § 6.3.2 Expected effects of experimental design factors in production situation I

We expect that our experimental design factors will affect several performance dimensions of the production system of production situation I. We are mainly interested in the effects on dependability and costs, as the speed of the system is constant in our experimental design. The production situation can be characterized as having a low capacity complexity within the cells. If a work order requires processing in a cell, all machines in this cell are visited, and the sequence in which they are visited is fixed. The fixed sequence and low capacity complexity make the simulated system sensitive to changes in volume. The dependability will strongly decrease if the volume (Vol) increases. The sequential dependency between operations and cells is also stronger in case N is small, as can be seen in Figure 6.11. Therefore, we expect a lower dependability if N is small, because of the start/finish effect.

A higher number of stages N causes the set-up time effect to occur, i.e. it reduces the net availability of machines and increases the set-up costs. A lower availability might result in a decreased dependability. The use of transfer batches might also lead to a lower net availability of machines, as the machines cannot effectively be used during the time they await delivery of input material for a succeeding transfer batch. If small transfer batches are used (NrSub high), the possibly lower availability of the machines will exaggerate the effect of the increased utilization, which possibly decreases dependability. If the set-up time effect at a higher number of stages will be as strong as the decrease in dependability because of the start/finish effect is not clear. Note that costs will increase if N and/or NrSub increases, because the total number of material transfers during T time units increases as accordingly.

The number of cells visited within a stage is only larger than one in case of  $N=1, 2$ , or  $3$ . The effect of IDD will therefore only become visible if these experimental conditions are valid. We expect a positive effect of the use of  $IDD=1$  on system dependability. The scheduling policy used will have effect on dependability. Shortest processing time (3, 4) usually results in a low number of orders tardy, and the same holds true for most work remaining rules (5,6). First in First out and shortest set-up time are both naïve rules in the context of situation I.

We consider only a small number of different products. This makes the system sensitive to changes in the order mix ( $AfwVol > 0$ ). We expect the strongest effect of this sensitivity in case of a small period length and hence a large number of stages. It decreases dependability.

The effect of the experimental design parameters on the total costs in production situation I depends not only on the number of set-ups, transfers, and the amount of stock in the system. The effect of overtime work on costs should also be taken into account.

### § 6.3.3 Methodology used to analyse the results

In order to determine the impact of the various experimental factors on the performance of the PBC system more formally, we have applied the Analysis of Variance (ANOVA) technique. Analysis of variance gives insight whether the means of subsets of all experiments for a specific performance measure are significantly different. The set of all experiments is decomposed into subsets according to the experimental factors that were used (the main effects) and their interaction. ANOVA computes the total variance in the performance measure for the whole set of experiments. This variance is first explained by covariates in order to filter out effects that are not caused by differences in the subsets. Next, ANOVA decomposes the remaining variance over the main effects and their interaction effects. Finally, ANOVA determines if the contribution of the individual subsets to the explanation of the total variance differs statistically significant from the contribution of the combination of subsets.

ANOVA can be used to determine these statistically significant means of the subsets. Note that ANOVA assumes that the variance of these subsets is equal when testing significance. This part of the analysis is very useful in determining the magnitude of the impact of various values of a main effect on the performance measure.

Finally, ANOVA estimates parameters in the model that help to estimate the value of the performance measure for combinations of experimental design factors that were not tested.

The *General Linear Model General Factorial procedure* of SPSS for Windows version 7.5.2 provides this type of analysis. After an overall F test has shown significance, a posteriori tests can be applied to evaluate differences among specific means. We have applied *Tukey's honestly significant difference test* in order to evaluate these differences and applied *Levene's test* for homogeneity of variance.

The simulation experiments have been performed on a Pentium II 266 Mhz PC. The mean CPU time for one replication was 7.8 seconds, and to perform the whole set of experiments took 30 hours computing time.

### § 6.3.4 Effect of PBC configuration on amount of overtime work

We are interested in the differences in the overtime requirements of the various PBC configurations. In order to compare the configurations, we determine the total overtime during N periods (i.e. during  $T=N \cdot P$ ) as performance measure. The total overtime is composed of the amount of work performed during overtime at all machines during N periods. The mean amount of work performed in overtime per machine per period P, denoted by  $W_m$ , is reported for all experiments. We sum these overtime working hours and multiply this sum with N, the number of periods these amounts of overtime work occur during a manufacturing throughput time T. So we used for each configuration:

$$\text{Total overtime during } T = N \cdot \sum_{m=1}^{15} \overline{W_m} \text{ (expressed in minutes)}$$

The use of a performance measure based on the amount of overtime work instead of a total tardiness oriented performance measure is preferred because of the difficulties with constructing an overall performance measure for all experiments. If two experiments that have a different numbers of stages both face an amount of tardiness per stage, we cannot simply sum up these tardiness-values over the stages, as the information contents of such a measure is very restricted. Using the amount of overtime work allows us to compare configurations of a PBC system with various stages.

An initial ANOVA analysis on the main effects and two-way interactions between the experimental design factors showed that the POLICY factor was significant, but further analysis with *Tukey's honestly significant difference test* showed that there was only a significant difference between the priority rules that use (a variant of) shortest processing time (rules 3 and 4) and the other rules 1, 2, 5, and 6. We have defined a new variable Pol2 that indicates if rule 3 or 4 is used (Pol2=1) or not (Pol2=0). In Table 6.3 we already introduced these values for Pol2. Using this new variable, we have applied our final ANOVA analysis.

We used the following model:

$$\begin{aligned} \text{TOTAL OVERTIME} = & \\ & \mu \\ & + \beta_i + \beta_j + \beta_k + \beta_l + \beta_m + \beta_n \\ & + \gamma_{ij} + \gamma_{ik} + \gamma_{il} + \gamma_{im} + \gamma_{in} + \gamma_{jk} + \gamma_{jl} + \gamma_{jm} + \gamma_{jn} + \gamma_{kl} + \gamma_{km} + \gamma_{kn} + \gamma_{lm} + \gamma_{ln} + \gamma_{mn} \\ & + \kappa_{ijk} + \kappa_{ijl} + \kappa_{ijm} + \kappa_{ijn} + \kappa_{ikl} + \kappa_{ikm} + \kappa_{ikn} + \kappa_{ilm} + \kappa_{iln} + \kappa_{imn} + \kappa_{jkl} + \kappa_{jkn} + \kappa_{jkm} + \kappa_{klm} + \kappa_{kln} + \kappa_{lmn} \\ & + \varepsilon \\ & i = 1..6(N); j = 1..4(NrSub); k = 1..2(Pol2); l = 1..3(Volume); m = 1..2(Edd); n = 1..2(AfwVol). \end{aligned}$$

The results of this analysis are presented in Table 6.5 and Table 6.6. The latter shows that all main effects are significant as well as the two-way interactions. The three-way interactions are significant except for four interactions involving NrSub, Pol2, Volume, Idd, and AfwVol. However, the impact of the three-way interaction in which N is not involved is far less than the interactions with N. This can be seen from the  $\text{Eta}^2$  column. The model has an adjusted R-squared of .999, which shows that the effect of the various POLICY values is very restricted.

Both the significance of all main effects in our analysis and the outcome of *Levene's test for homogeneity of variances* lead to the rejection of the null hypothesis that the means for the tested values of the main effect are equal. However, it does not reveal if all tested values of the main effects have different means. We therefore have to determine which means differ.

We have applied *Tukey's honestly significant difference test* to compare the means. The estimated main effects and the difference with the first factor level of a main effect with accompanying 95% confidence interval are displayed in Table 6.5. The differences between the means obtained for the tested values of the main effects were all significant at the 5% level.

TOTAL OVERTIME		Mean	Std. Error	Difference with first factor of main effect	Sig. (0.05)	95% confidence interval of difference	
Grand Mean		4492.7	5.35			Lower	Upper
N	1	13384.1	13.10				
	2	3656.4	13.10	-9727.8	0.000	-9782.2	-9673.3
	3	3947.6	13.10	-9436.6	0.000	-9491.0	-9382.1
	4	2607.5	13.10	-10776.6	0.000	-10831.1	-10722.2
	5	2182.8	13.10	-11201.3	0.000	-11255.8	-11146.8
	6	1177.6	13.10	-12206.5	0.000	-12261.0	-12152.0
NrSub	1	8832.8	10.70				
	2	4020.3	10.70	-4812.6	0.000	-4852.5	-4772.6
	3	2811.3	10.70	-6021.5	0.000	-6061.5	-5981.6
	4	2306.2	10.70	-6526.6	0.000	-6566.6	-6486.6
Pol2	0	4265.1	6.18				
	1	4720.2	8.74	455.1	0.000	434.1	476.1
Volume	60	1278.6	9.27				
	75	3657.7	9.27	2379.1	0.000	2347.7	2410.5
	90	8541.7	9.27	7263.2	0.000	7231.8	7294.6
Idd	0	4437.9	7.57				
	1	4547.4	7.57	109.6	0.000	88.6	130.6
AfwVol	0	4297.8	7.57				
	4	4687.5	7.57	389.7	0.000	368.7	410.7

**Table 6.5 Estimated main effects**

TOTAL OVERTIME explained		sum of squares	df	Mean Square	F	Sig.	Eta <sup>2</sup>	Power
Corrected Model		67057385289	231	290291711	6602.87	0.000	0.999	1
$\mu$	Intercept	31002665198	1	31002665198	705175.74	0.000	0.998	1
$\beta_i$	N	25582993414	5	5116598683	116380.36	0.000	0.997	1
$\beta_j$	NRSUB	10240396690	3	3413465563	77641.49	0.000	0.994	1
$\beta_k$	POL2	79523753	1	79523753	1808.82	0.000	0.547	1
$\beta_l$	VOLUME	14040396981	2	7020198490	159678.97	0.000	0.995	1
$\beta_m$	IDD	4609444	1	4609444	104.84	0.000	0.065	1
$\beta_n$	AFWVOL	58323512	1	58323512	1326.61	0.000	0.470	1
$\gamma_{ij}$	N · NRSUB	3528910541	15	235260703	5351.16	0.000	0.982	1
$\gamma_{ik}$	N · POL2	469745632	5	93949126	2136.93	0.000	0.877	1
$\gamma_{il}$	N · VOLUME	4196007278	10	419600728	9544.09	0.000	0.985	1
$\gamma_{im}$	N · IDD	24101559	5	4820312	109.64	0.000	0.268	1
$\gamma_{in}$	N · AFWVOL	64461262	5	12892252	293.24	0.000	0.495	1
$\gamma_{jk}$	NRSUB · POL2	28359393	3	9453131	215.02	0.000	0.301	1
$\gamma_{jl}$	NRSUB · VOLUME	2143539076	6	357256513	8126.03	0.000	0.970	1
$\gamma_{jm}$	NRSUB · IDD	4406485	3	1468828	33.41	0.000	0.063	1
$\gamma_{jn}$	NRSUB · AFWVOL	20999947	3	6999982	159.22	0.000	0.242	1
$\gamma_{kl}$	POL2 · VOLUME	2146522	2	1073261	24.41	0.000	0.032	1
$\gamma_{km}$	POL2 · IDD	5234998	1	5234998	119.07	0.000	0.074	1
$\gamma_{kn}$	POL2 · AFWVOL	12019222	1	12019222	273.38	0.000	0.155	1
$\gamma_{lm}$	VOLUME · IDD	1004720	2	502360	11.43	0.000	0.015	0.993
$\gamma_{ln}$	VOLUME · AFWVOL	15850004	2	7925002	180.26	0.000	0.194	1
$\gamma_{mn}$	IDD · AFWVOL	1896608	1	1896608	43.14	0.000	0.028	1
$\kappa_{ijk}$	N · NRSUB · POL2	126760339	15	8450689	192.22	0.000	0.658	1
$\kappa_{ijl}$	N · NRSUB · VOLUME	463650669	30	15455022	351.53	0.000	0.876	1
$\kappa_{ijm}$	N · NRSUB · IDD	29004909	15	1933661	43.98	0.000	0.306	1
$\kappa_{ijn}$	N · NRSUB · AFWVOL	1573124	15	104875	2.39	0.002	0.023	0.988
$\kappa_{ikl}$	N · POL2 · VOLUME	17287950	10	1728795	39.32	0.000	0.208	1
$\kappa_{ikm}$	N · POL2 · IDD	25382747	5	5076549	115.47	0.000	0.278	1
$\kappa_{ikn}$	N · POL2 · AFWVOL	13170931	5	2634186	59.92	0.000	0.167	1
$\kappa_{ilm}$	N · VOLUME · IDD	9201963	10	920196	20.93	0.000	0.123	1
$\kappa_{iln}$	N · VOLUME · AFWVOL	33419907	10	3341991	76.02	0.000	0.337	1
$\kappa_{imn}$	N · IDD · AFWVOL	5084807	5	1016961	23.13	0.000	0.072	1
$\kappa_{jkl}$	NRSUB · POL2 · VOLUME	3181196	6	530199	12.06	0.000	0.046	1
$\kappa_{jkm}$	NRSUB · POL2 · IDD	1552117	3	517372	11.77	0.000	0.023	1.000
$\kappa_{jkn}$	NRSUB · POL2 · AFWVOL	265245	3	88415	2.01	*0.110	0.004	0.519
$\kappa_{jlm}$	NRSUB · VOLUME · IDD	194347	6	32391	0.74	*0.620	0.003	0.296
$\kappa_{jln}$	NRSUB · VOLUME · AFWVOL	348059	6	58010	1.32	0.245	0.005	0.524
$\kappa_{jmn}$	NRSUB · IDD · AFWVOL	358561	3	119520	2.72	0.043	0.005	0.662
$\kappa_{klm}$	POL2 · VOLUME · IDD	447805	2	223903	5.09	0.006	0.007	0.822
$\kappa_{kln}$	POL2 · VOLUME · AFWVOL	2129706	2	1064853	24.22	0.000	0.031	1
$\kappa_{kmn}$	POL2 · IDD · AFWVOL	1378046	1	1378046	31.34	0.000	0.021	1
$\kappa_{lmn}$	VOLUME · IDD · AFWVOL	34237	2	17118	0.39	*0.678	0.001	0.113
Error		65770821	1496	43964				
Total		00833463972	1728					
Corrected Total		67123156110	1727					

\*Not significant (alpha = .05)

R Squared = .999 (Adjusted R Squared = .999)

Table 6.6 ANOVA analysis: Tests of Between-Subjects Effects

The main results of our analysis that can be derived from Table 6.5 are:

- *total overtime decreases rapidly if the number of stages N becomes larger and P lower.*

A change in PBC configuration has a substantial effect on the amount of overtime work, even if the total throughput time remains constant. If N increases the amount of overtime decreases. From this we conclude that the start/finish effect diminishes much stronger than the set-up time effect increases. Note that the start/finish effect is caused by sequence dependent operations within the stage, and the occurrence of such dependencies decreases if N increases, as we apply a reallocation of operations to these stages. Therefore, we expected the start/finish effect to decrease and the set-up time effect to increase with an increase in N. The results show that both effects are not equally strong in the simulated production situation. This confirms the anomalous effect that we described in Figure 6.6 of Section § 6.1 for the utilization of a bottleneck.

Table 6.5 shows an increase in the amount of overtime when changing from N=2 to N=3 stages. There are two explanations for this increase. First, the change in the number of stages from N=2 to N=3 does not result in a reallocation of the operations in the final stage, as can be seen in Figure 6.11. The increase in the amount of overtime work is therefore partly caused by the set-up time effect in this last stage, which reduces the net available regular production time. The reduction in period length results in a smaller quantity that has to be produced, but it requires more throughput time than the net available regular production time, because of the set-up time effect. Second, we might face both a *decrease* of overtime work *per period* if N increases and an *increase* in the total amount of overtime work during the total manufacturing throughput time T. The reason is that we have to multiply the amount of overtime work per period with the number of periods N we face during T.

- *total overtime decreases if the number of transfer batches NrSub increases.*

The increase in the number of transfer batches has an almost identical effect as the increase in the number of stages N: the amount of overtime work decreases. The effect of an increase in the number of transfer batches is not exponential. In Table 6.7 (left side) we see that a change from one to two batches per period causes on average an overtime reduction with 58%, while a change from two to four subbatches causes a further overtime reduction, but with a smaller percentage (average 48%). For N=1 the relative effect of extra subbatches is smaller than for higher number of stages. This is remarkable, as N=1 results in the highest amounts of overtime work. Still, the absolute decrease in the amount of overtime work is substantial.

An increase in N and an increase in the number of transfer batches NrSub both result in an increase in transfer costs. We can identify configurations of the PBC system that will result in identical transfer costs during T. These configurations have an equal product of N and NrSub. The right side of Table 6.7 shows that such configurations usually result in significantly different amounts of overtime. This indicates that it is not sufficient to specify the design of a

PBC system in terms of the number of transfers of batches *during T* (i.e., to specify the product of N and NrSub). The additional factor that influences the total amount of overtime work is the allocation of operations to stages. This factor causes the occurrence of the start/finish effect, and hence it is a very important design factor in a PBC system.

N	Nrsub=1	Nrsub=2	Nrsub=3	Nrsub=4	N·Nrsub	(N,Nrsub):	(N,Nrsub):	(N,Nrsub):
1	22188	12776	9913	8659	2	(1,2) 12276	(2,1) 9114	
2	9114	2853	1585	1074	3	(1,3) 9913	(3,1) 9149	
3	9149	3346	1937	1359	4	(1,4) 8659	(2,2) 2853	(4,1) 5750
4	5750	2221	1401	1058	6	(2,3) 1585	(3,2) 3346	(6,1) 2250
5	4546	1895	1264	1025	8	(2,4) 1074	(4,2) 2221	
6	2250	1031	768	662	12	(3,4) 1359	(4,3) 1401	(6,2) 1031

**Table 6.7 Overtime performance data for configurations with identical transfer costs**

The results of Table 6.7 confirm the anomalous effect described in Figure 6.7 in Section § 6.1. The effect of an increase in P and decrease in N on system dependability can often only partly be recovered by an increase in the number of transfer batches. Our results show that generally a decrease in N should be combined with an increase in the product of N and NrSub in order to achieve the same amount of overtime work. The number of transfer batches NrSub should increase faster than N decreases. This results in higher transfer costs during T.

- *total overtime increases if shortest processing time scheduling is applied at cell level.*

We face an increase in the amount of overtime work if cell scheduling policies with Pol2=1 are used. Pol2=1 indicates that either rule 3 (SPT: shortest processing time) or rule 4 (SSPT: shortest set-up + processing time) is used instead of simple rules as FIFO, shortest set-up time SST, or more complex remaining work oriented rules as MWRC and MWRS (Most Work Remaining either in Cell or Stage).

The reason for this increase in overtime work is that with shortest processing time rules the longest processing time operations are postponed and often start near the end of the period. Machines that are required for these jobs face idle time during the period, but they have to perform overtime work for these long jobs. The shortest processing time rules do not follow the principle behind Johnson’s optimal two machine flow shop scheduling rule (Johnson (1954)). This rule states that start/finish effects can be minimized (or stated else: minimum make span can be achieved) by putting the longest operations in the middle of the schedule. If long processing time jobs are scheduled at the start of a period, the successive machines wait too long before they start. If they are scheduled at the end of the period, the final machines face a too late finish time. The make span can therefore be shortened by reducing the start/finish delays.

- *total overtime increases if higher volumes are pushed into the system.*

This effect of higher volumes is not surprising. It was not our purpose to show that an increase in volume would have effect on the amount of overtime work, but to show that the significance of the other design factors did not change. However, we observe some notable aspects from Table 6.5. We have applied a symmetrical design of the three volume levels: Volume=60, 75, and 90. However, the mean total overtime in case Volume=75 is not equal to the Grand Mean of 4492.7, but more than 800 minutes lower. This is mainly caused by the truncated distribution of overtime work, which has a strict minimum at 0. The situations where there is no overtime work are mainly found for Volume=60 or 75, so the Grand Mean is higher than the mean overtime for Volume=75.

- *total overtime increases (!) if stage co-ordination is applied for production orders that require further processing in another cell in the same stage (i.e., if  $IDD=1$ ).*

This can only occur for  $N=1, 2$ , or  $3$ , as the stage allocation for higher  $N$  will not result in sequence dependent cells within a stage (see Figure 6.11). Differentiation of internal due dates is then not necessary. Further analysis in Table 6.8 below shows that the only significant difference between  $IDD=0$  or  $1$  for various values of  $N$  is at  $N=1$ . Hence, the high amount of overtime work for  $N=1$  is not caused by improper co-ordination of the sequential relationships between the cells.

- *total overtime increases if random deviations from the mean order size occur ( $AfwVol=4$ )*

Although the mean order size remains constant, the mean amount of overtime work increases with almost 10% if the order mix fluctuations increase. In Table 6.8 we find that this effect occurs not uniform for all numbers of stages  $N$ . For  $N=1$ , even the opposite effect takes place. A PBC configuration with  $N=1$  is therefore less sensitive for changes in the mean order size. For higher numbers of stages ( $N=6$ ) the amount of overtime increases if mix fluctuations increase.

Another explanation for the increase in overtime at  $N=6$  is the truncated distribution of overtime work. Suppose a configuration generally requires no overtime for a certain production volume. A momentary increase in the production volume with 10% may cause an (extra) amount of overtime work, while a decrease of the production volume with 10% leaves the amount of overtime at zero level. Hence, fluctuating production volumes make the mean amount of overtime increase. At  $N=6$  we generally face the least amount of overtime work; hence it is more sensitive for this truncation effect.

From Table 6.6 we know that the interaction effect of the input parameters is significant. In Table 6.8 we present the two way interactions of the ANOVA model. We already referred to this table in our presentation of the results of our analysis above. The table requires some

explanation. It consists of information identical to Table 6.5, but presents it as percentage differences. The (fat marked) block diagonal shows these percentage differences with the left factor of the main effect that is considered. The values at the diagonal duplicate Table 6.5.

The next columns of Table 6.8 present the two way interactions with their mean value in the analysis. This is the additional part of the analysis. The columns and rows of the matrix show the values of the various PBC design factors. The combination of a row and column value shows the mean amount of overtime work for all PBC configurations with the given values for these two design factors.

	N						NrSub				Vol			Pol2		IDD		AfwVol		
	1	2	3	4	5	6	1	2	3	4	90	75	60	1	0	1	0	4	0	
N	1	13384	27%	29%	19%	16%	9%	22188	12776	9913	8659	21449	12760	5943	14839	11929	13719	13049	13177	13591
	2		3656	108%	71%	60%	32%	9114	2853	1585	1074	7809	2613	547	3632	3681	3660	3653	3816	3497
	3			3948	66%	55%	30%	9149	3346	1937	1359	8334	2859	650	3794	4101	3947	3948	4154	3741
	4				2607	84%	45%	5750	2221	1401	1058	5943	1664	215	2613	2602	2601	2614	2955	2260
	5					2183	54%	4546	1895	1264	1025	4864	1450	235	2196	2169	2183	2182	2396	1970
	6						1178	2250	1031	768	662	2851	599	82	1247	1108	1174	1181	1628	727
NrSub	1						8833	46%	32%	26%	15293	7900	3306	8839	8827	8806	8860	9222	8444	
	2							4020	70%	57%	8030	3179	852	4249	3792	4061	3979	4205	3836	
	3								2811	82%	5903	1994	537	3137	2486	2912	2710	2923	2700	
	4									2306	4940	1558	420	2657	1956	2410	2202	2401	2212	
Vol	90									8542	43%	15%	8809	8275	8626	8457	8847	8236		
	75										3658	35%	3896	3419	3715	3600	3877	3439		
	60											1279	1456	1101	1301	1256	1339	1218		
Pol2	1												4720	90%	4717	4724	4827	4614		
	0													4265	4378	4152	4548	3982		
IDD	1														4547	98%	4707	4388		
	0															4438	4668	4208		
AfwVol	4																	4687	92%	
	0																		4297	

Table 6.8 Two way interactions

The mean total overtime that is reported describes the required minutes of overtime work during N periods. The values obtained are for several sets of experiments very high. This may seem unrealistic, but it does give us an impression of the sensitivity of the PBC system for changes in input parameters. We therefore do not pay much attention to the way a PBC system that faces such a huge mean overtime should handle this in practice, e.g. by using modified work time schedules, extra shifts for specific machines, and so on. The aim of our analysis is to reveal that the selection of a different configuration with identical throughput time has effect on the resulting amount of overtime work.

### § 6.3.5 Effect of PBC configuration on costs

In order to accomplish a time/cost trade-off for different configurations of a PBC system with identical throughput time, we should also reveal the effect of different configurations on the various cost factors. We do not have cost information on the simulated production situation that is described in Steele, Berry, and Chapman (1995). However, we are able to show how to analyse cost results with our simulation model, and what effect a PBC configuration change will have on the cost components and total cost curve.

We distinguish as components of the total cost: holding costs, overtime costs, set-up costs, and transfer costs. We will first discuss these components of the total cost curve. Afterwards, in Figure 6.13 we show the mean total cost curve and its components as a function of the number of stages N and the number of subbatches NrSub.

#### *Holding costs*

The holding costs were also introduced as component of the total costs in Chapter Five. However, the calculation of these costs can be more precise as we do have information on the allocation of operations to the stages. As we determine the effect of different configurations of the PBC system, we have to take into account the effect on the holding costs as well.

In our simulation analysis, we determine holding costs based on the stage allocation. We assume that input material for operations in a stage is available at the start of the period in which it is required.

Holding costs further depend on the value of the work in process. If operations are performed in a stage, the value of this work increases after completion. This increase is counted for in the holding cost. Hence, priority rules may influence holding costs, but stage allocation and number of stages do generally have a much higher impact on this cost component.

The simulation results show a slightly decreasing holding cost curve for increasing values of N. This curve (marked with a \*) is presented in the left side in Figure 6.13 and shows holding cost values between 800 and 1200 over a throughput time of length T. We expected the decreasing trend for increasing values of N, but the curve is smoother than we expected. The reason is twofold:

First, the effect of the increase of the WIP value during the period diminishes if more work is performed during overtime. From our analysis, we know that at low N we require on average more overtime work. The way we measure the holding costs therefore flattens the holding cost curve. If the holding cost curve would be less sensitive to the increase in the value of work in progress during a period, we would face a steeper descending holding cost curve for increasing values of N.

Second, the effect of the allocation of operations to the stages was not taken into account in our theoretical analysis in Section § 6.1 on the effect of an increase in N and a decrease in P. If the operations are equally divided over the stages, than our analysis is still correct. However, if the number of operations (or their value) varies strongly per stage, the effect is disturbed. The stage allocation that we have applied does not result in an equal distribution of the number of operations over the stages, as the number of operations per processing stage differs.

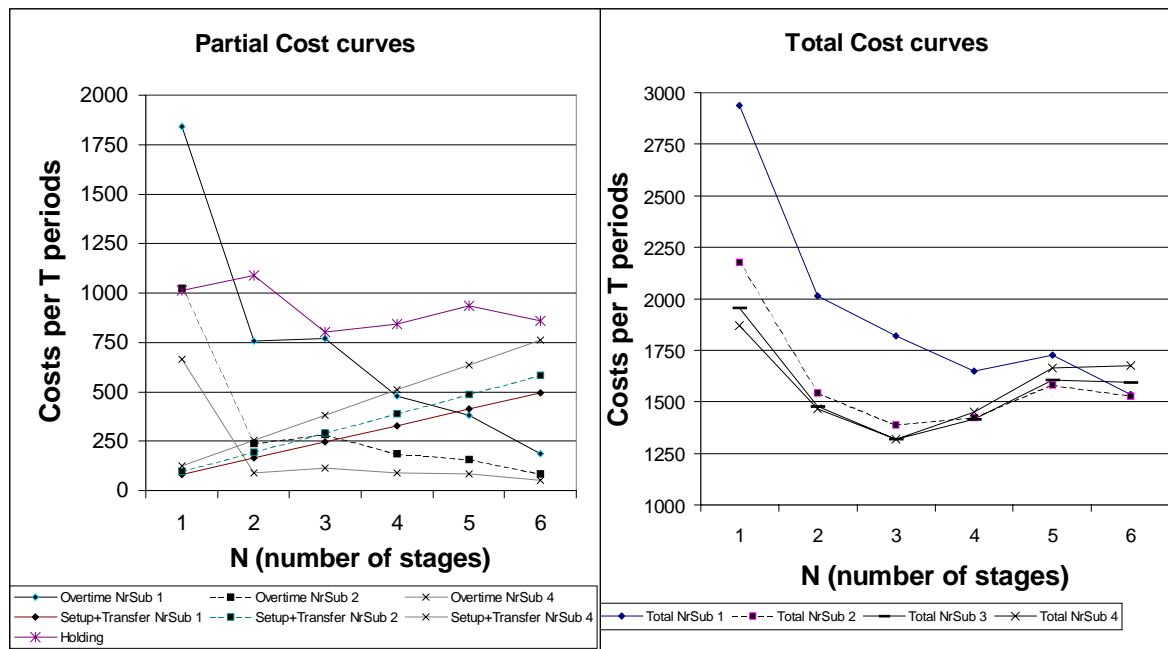

Figure 6.13 Cost curves for combinations of N and NrSub

*Set-up and transfer costs*

The curves of set-up and transfer costs are as we expected. We refer to Chapter Five for a discussion on these curves. Note that the set-up costs are a linear function of N and the transfer costs are a linear function of N·NrSub.

*Overtime costs*

The overtime costs represent the cost of working hours during overtime. We see from the left side in Figure 6.13 that the effect of an increase in the number of stages N on the cost of overtime is substantial. The effect of an increase in the number of transfer batches is also considerable. Overlapping production can only partially solve the problem of overtime work.

### Total costs

The right side in Figure 6.13 shows four total cost curves, one for each number of transfer batches (for easy of presentation we have omitted the curve for  $NrSub=3$  in the left side of the figure). The total cost curves show high costs at a low number of stages  $N$  that first decrease if  $N$  gets larger, and after some point again an increase. The reason for this pattern is that at a low number of stages  $N$  the overtime costs are high, but they decrease rapidly with an increase in  $N$ . At higher  $N$ , the set-up and transfer costs increase. This is as we expected.

Note that the total cost curves cross each other instead of staying on equal distance. Crossing of the cost curves takes place because at lower values of  $N$  ( $N=1, 2$ , and  $3$ ) the least total costs occur for high numbers of subbatches ( $NrSub=3$  or  $4$ ), while at  $N=4, 5$  or  $6$  the least costs occur for  $NrSub = 1$  or  $2$ . The arrangement of the curves with respect to the cost they incur completely reverses if  $N$  increases! The product of  $N$  and  $NrSub$  is hence an important factor in determining the total cost of the system, as shown in Figure 6.14.

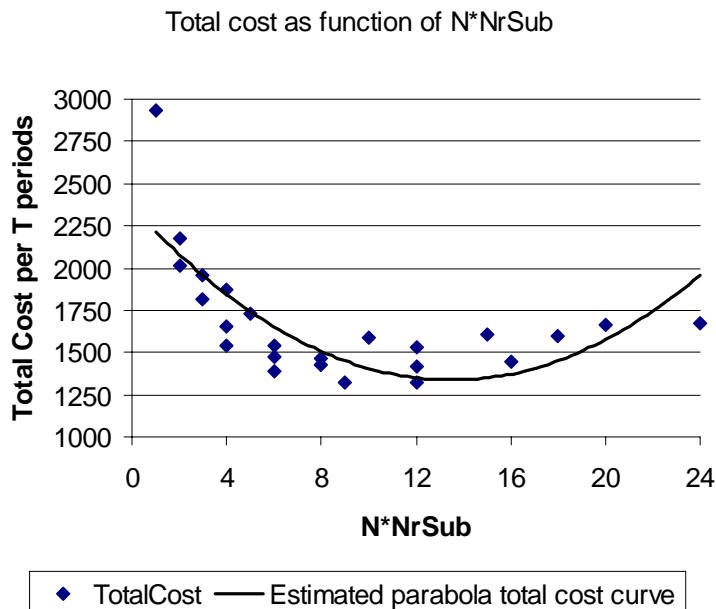

**Figure 6.14 Total cost as function of total number of transfers during T**

The overall minimum does occur at  $N=3$  and  $NrSub = 4$ . However, the pattern of the cost functions is much more important, as this shows that different configurations of the PBC system have a strong impact on the total cost of operating the system. An ANOVA analysis showed us that the mean total costs that we present for the various policies are significantly different.

Concluding, we have shown that various configurations of the PBC system with the same manufacturing throughput time  $T$  result in significantly different amounts of overtime work and costs. The factors that have the most impact are the number of stages  $N$  and the number of transfer batches  $NrSub$ . The product of both factors is important for cost optimization.

## § 6.4 Performance of PBC in production situation II

The results obtained so far consider a cellular manufacturing system for production of small industrial vehicles that has been described by Steele and Malhotra (1997) (see Section § 6.2.2). An essential characteristic of this production system is the low capacity complexity within the cells. There are only three end products and each product has the same routing. If a product requires processing in a cell, then all machines are visited. The sequence in which they are visited is identical for all products and parts, i.e. it is a flow line cell.

The question rises if the results are still valid if we apply PBC in other production situations. Answering this question is quite difficult, as there are numerous different production situations that will have to be tested. Factors such as number of products, capacity complexity, number of cells, required number of operations per cell, processing time variability, set-up time variability, and so on, and their interaction may influence the results. Although our simulation program can be used for such tests, such an analysis would go beyond the scope of our research project.

However, it is important for us to examine the validity of our research outcomes for more complex production situations. We have chosen to consider the impact of the flow line characteristics of the simulated cellular manufacturing system. Chapter Two has described several cells in Dutch metal ware fabrication, and almost all cells faced different routings within the cell. We will explore the sensitivity of the results obtained so far for a change in the flow within the cells. We want to answer the following question:

*do the results that were obtained for production situation I remain valid  
if the characteristics of this production situation  
with respect to the capacity complexity and the flow within the cells are changed,  
all other things being equal?*

The introduction of routing variety in the cells creates a different production situation that we will denote as production situation II.

The stage allocation for this production situation is identical to production situation I, but the routings within the cells do vary. The new routings are created such that a maximum variety results with respect to the sequence in which machines within the cells are required<sup>1</sup>. Note that the newly introduced routings do not have any practical meaning for the production system of Section § 6.2.2, but they are considered in order to evaluate the effect of more variety in the production system.

---

<sup>1</sup> For example, if product two visits cell II, it first requires processing on machine 5, next on machine 4, and finally on machine 3, while product one visits these machines in the normal order 3 → 4 → 5, and product three first visits machine 4, then 5, and finally 3.

The routing variety complicates the scheduling within the cell. It makes it possible to reduce the start/finish lag within a period. According to the results of Section § 6.3.4 this will make lower values of N more attractive. More routing variety may also lead to longer throughput times due to the increased possibility of waiting time before a machine starts processing a job. Therefore, the net effect of this change in the production situation is not obvious and has to be studied.

We want to determine if different configurations of the PBC system with identical throughput times T result in significant effects on the amount of overtime work and costs. If this can be concluded, we want to determine if the effect of the design factors has changed.

The experimental design for simulating production situation II is identical to the design for situation I. Note that the effect of the experimental design factors, such as the introduction of extra transfer batches, can only be compared with situation I if the number of products is equal and these products have a similar structure. This illustrates the rationale behind our choice to keep all other data constant.

#### § 6.4.1 Results for production situation II

The results of the simulation experiments are analysed with ANOVA in order to find out if there is a significant difference in performance between various levels of the main effects. The ANOVA table is presented in Table 6.10. It shows that all main effects are significant, so we cannot conclude that the null-hypothesis (all means for the levels of a main effect are equal) holds true. Many of the interaction effects are also significant.

We conclude from this table that our main results remain valid in production situation II as well. The effect of varying N on the total amount of overtime in the production system is highly significant and does interact with the other experimental design factors.

*Tukey's honestly significant difference tests* showed that the various levels of the main effects were all significant at a 0.05 level. The means are presented in Table 6.9 below.

Table 6.9 shows that there are surprising differences with production situation I:

- The mean total overtime increases if the routing variety increases. The routing variety leads to the introduction of longer throughput times due to the increased possibility of waiting time before a machine starts processing a job. The effect of these longer throughput times exaggerates the start/finish effect that also occurs.
- The effect of the number of stages N on the total amount of overtime is even more distinct than in production situation I. N=1 leads to relatively higher amounts of overtime, while N=6 leads to substantially lower amounts of overtime. The total variance that can be allocated to varying N has increased (compare Table 6.6 and Table 6.10).

- N=2 and N=3 result in almost identical amounts of overtime. *Tukey's test* showed no true difference between the means. Situation I did show an increase in the amount of overtime between N=2 and N=3, due to the start/finish effect and identical stage contents in the last stage. The introduction of routing variety decreases the start/finish effect in this stage.
- The amount of overtime is less sensitive for varying the number of transfer batches NrSub. The variance that is explained by different levels of NrSub relatively decreased, and the difference between one transfer batch (NrSub=1) and extra transfer batches (NrSub=2,3,4) diminishes. This shows that the return on investment of using transfer batches is highest in case permutation flow shop schedules are being applied, a result that agrees with our knowledge from flow shop scheduling research.
- The size of the interaction effect of transfer batches and volume is smaller. The effect of introducing extra transfer batches results therefore in relatively smaller differences for various volumes of the order package than in case of production situation I.
- The effect of the cell scheduling policy that is applied is small but significant. The most surprising is that in situation II the shortest processing time related rules outperform the other rules. This is just opposite to the results obtained for situation I, where processing time rules resulted in higher amounts of overtime work. The main contribution for this change comes from the higher sensitivity for differences in order size in this situation II (AfwVol, Volume), and the lower sensitivity for different values of N.
- The use of Idd does have relatively less effect on the increase in the amount of overtime.

TOTAL OVERTIME		Mean	Std. Error	Difference with first factor of main effect	Sig. (0.05)	95% confidence interval of difference	
Grand Mean		5215.5	17.13			Lower	Upper
N	1	16775.5	41.96				
	2	4626.0	41.96	-12149.5	0.000	-12324.0	-11975.1
	3	4623.9	41.96	-12151.6	0.000	-12326.1	-11977.2
	4	2865.5	41.96	-13910.0	0.000	-14084.5	-13735.6
	5	1964.9	41.96	-14810.6	0.000	-14985.0	-14636.2
	6	437.0	41.96	-16338.5	0.000	-16512.9	-16164.1
NrSub	1	8553.3	34.26				
	2	5049.2	34.26	-3504.2	0.000	-3632.1	-3376.2
	3	3899.2	34.26	-4654.1	0.000	-4782.1	-4526.1
	4	3360.1	34.26	-5193.2	0.000	-5321.1	-5065.2
Pol2	0	5264.5	19.78				
	1	5166.4	27.97	-98.1	0.004	-165.3	-30.9
Volume	60	1711.5	29.67				
	75	4562.8	29.67	2851.2	0.000	2750.7	2951.8
	90	9372.1	29.67	7660.6	0.000	7560.0	7761.1
Idd	0	5171.3	24.22				
	1	5259.6	24.22	88.3	0.010	21.1	155.4
AfwVol	0	5015.6	24.22				
	4	5415.3	24.22	399.6	0.000	333.0	466.8

Table 6.9 Estimated main effects Production Situation II

TOTAL OVERTIME explained		sum of squares	df	Mean Square	F	Sig.	Eta <sup>2</sup>	Power
Corrected Model		87120720799	231	377145977	9863.31	0.000	0.999	1
$\mu$	Intercept	41780779649	1	41780779649	1092671.54	0.000	0.999	1
$\beta_i$	N	44353142330	5	8870628466	231989.05	0.000	0.999	1
$\beta_j$	NRSUB	6275958899	3	2091986300	54710.66	0.000	0.991	1
$\beta_k$	POL2	3692902	1	3692902	96.58	0.000	0.061	1
$\beta_l$	VOLUME	15350351372	2	7675175686	200724.98	0.000	0.996	1
$\beta_m$	IDD	2990694	1	2990694	78.21	0.000	0.050	1
$\beta_n$	AFWVOL	61330646	1	61330646	1603.95	0.000	0.517	1
$\gamma_{ij}$	N · NRSUB	2905671279	15	193711419	5066.04	0.000	0.981	1
$\gamma_{ik}$	N · POL2	12280238	5	2456048	64.23	0.000	0.177	1
$\gamma_{il}$	N · VOLUME	6876031509	10	687603151	17982.54	0.000	0.992	1
$\gamma_{im}$	N · IDD	14569900	5	2913980	76.21	0.000	0.203	1
$\gamma_{in}$	N · AFWVOL	9861449	5	1972290	51.58	0.000	0.147	1
$\gamma_{jk}$	NRSUB · POL2	863336	3	287779	7.53	0.000	0.015	0.987
$\gamma_{jl}$	NRSUB · VOLUME	663581592	6	110596932	2892.39	0.000	0.921	1
$\gamma_{jm}$	NRSUB · IDD	1184799	3	394933	10.33	0.000	0.020	0.999
$\gamma_{jn}$	NRSUB · AFWVOL	130668	3	43556	1.14	*0.332	0.002	0.309
$\gamma_{kl}$	POL2 · VOLUME	8340271	2	4170135	109.06	0.000	0.127	1
$\gamma_{km}$	POL2 · IDD	325598	1	325598	8.52	0.004	0.006	0.831
$\gamma_{kn}$	POL2 · AFWVOL	17568905	1	17568905	459.47	0.000	0.235	1
$\gamma_{lm}$	VOLUME · IDD	1241136	2	620568	16.23	0.000	0.021	1
$\gamma_{ln}$	VOLUME · AFWVOL	23840920	2	11920460	311.75	0.000	0.294	1
$\gamma_{mn}$	IDD · AFWVOL	649264	1	649264	16.98	0.000	0.011	0.985
$\kappa_{ijk}$	N · NRSUB · POL2	6432450	15	428830	11.21	0.000	0.101	1
$\kappa_{ijl}$	N · NRSUB · VOLUME	563626523	30	18787551	491.34	0.000	0.908	1
$\kappa_{ijm}$	N · NRSUB · IDD	6136147	15	409076	10.70	0.000	0.097	1
$\kappa_{ijn}$	N · NRSUB · AFWVOL	17310786	15	1154052	30.18	0.000	0.232	1
$\kappa_{ikl}$	N · POL2 · VOLUME	6139536	10	613954	16.06	0.000	0.097	1
$\kappa_{ikm}$	N · POL2 · IDD	1306042	5	261208	6.83	0.000	0.022	0.998
$\kappa_{ikn}$	N · POL2 · AFWVOL	36390300	5	7278060	190.34	0.000	0.389	1
$\kappa_{ilm}$	N · VOLUME · IDD	7511857	10	751186	19.65	0.000	0.116	1
$\kappa_{iln}$	N · VOLUME · AFWVOL	27200952	10	2720095	71.14	0.000	0.322	1
$\kappa_{imn}$	N · IDD · AFWVOL	4912337	5	982467	25.69	0.000	0.079	1
$\kappa_{jkl}$	NRSUB · POL2 · VOLUME	2244904	6	374151	9.78	0.000	0.038	1
$\kappa_{jkm}$	NRSUB · POL2 · IDD	3606	3	1202	0.03	*0.993	0.000	0.056
$\kappa_{jkn}$	NRSUB · POL2 · AFWVOL	1441015	3	480338	12.56	0.000	0.025	1
$\kappa_{jlm}$	NRSUB · VOLUME · IDD	183016	6	30503	0.80	*0.572	0.003	0.321
$\kappa_{jln}$	NRSUB · VOLUME · AFWVOL	1652031	6	275339	7.20	0.000	0.028	1
$\kappa_{jmn}$	NRSUB · IDD · AFWVOL	1231138	3	410379	10.73	0.000	0.021	0.999
$\kappa_{klm}$	POL2 · VOLUME · IDD	96970	2	48485	1.27	*0.282	0.002	0.276
$\kappa_{kln}$	POL2 · VOLUME · AFWVOL	1951388	2	975694	25.52	0.000	0.033	1
$\kappa_{kmn}$	POL2 · IDD · AFWVOL	265037	1	265037	6.93	0.009	0.005	0.749
$\kappa_{lmn}$	VOLUME · IDD · AFWVOL	291497	2	145749	3.81	0.022	0.005	0.694
Error		57202960	1496	38237				
Total		134476362953	1728					
Corrected Total		87177923759	1727					

\*Not significant (alpha = .05)

R Squared = .999 (Adjusted R Squared = .999)

**Table 6.10 ANOVA analysis Production Situation II: Tests of Between-Subjects Effects**

### § 6.4.2 Conclusions on comparing production situations I and II

We conclude that the main results that we obtained for production situation I remain valid in production situation II as well. Hence, the introduction of routing variety has no effect on the determination of the important factors that have to be taken into account when designing a PBC system. Most important design factors are the number of stages  $N$ , stage allocation, and the number of transfer batches  $NrSub$ .

The introduction of routing variety (situation II), order size variety ( $AfwVol$ ), or volume variety (Volume) results in different amounts of overtime, but does not result in a fundamental change in the importance of the design factors mentioned above.

An increase in routing variety results on average in higher amounts of overtime work. The effect of an increase in the number of transfer batches diminishes. Furthermore, the system becomes less sensitive for using the same stage contents if a shorter period length applies

More routing variety makes the effect of a change in  $N$  still more distinct. The difference in the amount of overtime work between configurations with small  $N$  and large  $N$  enlarges.

The use of cell scheduling rules (Policy) or within-stage co-ordination (Idd) has a relatively small influence on the amount of overtime work. Shortest processing time rules have an increasing effect on the amount of overtime work in situation I, and a decreasing effect if routing variety is present (situation II).

## § 6.5 Conclusions

This chapter has addressed the effect of PBC system design factors on the performance. From literature, we know that a reduction in the period length or the number of stages has important benefits. However, these benefits can partly be deduced from the reduction in the manufacturing throughput time that they cause. We have considered different PBC system designs that all result in an identical throughput time. Our analysis has revealed that the trade-off between the size of  $N$  (number of stages) and  $P$  (length of period) in the design of a PBC system is essential, even if their product  $T=N \cdot P$  is constant.

A configuration with large  $P$  and small  $N$  results in less set-up time and less frequent start/finish losses, but also in higher amounts of overtime work.

A configuration with small period length and large  $N$  results in easier co-ordination and control, higher bottleneck utilization, smaller order lead times, but also in higher set-up and transfer (=material handling) costs.

Most important factors that influence the amount of overtime work and costs for systems with equal throughput time  $T=N \cdot P$  are the number of stages  $N$ , the number of transfer batches  $NrSub$ , and the contents of the stages. The difference between the various configurations in the amount of overtime work required is highly significant.

The analysis of the differences in the costs of the various configurations showed that systems with a small number of stages  $N$  face both low set-up and transfer costs, and high overtime and holding costs. The total number of transfers during  $T$  (the product of the number of stages  $N$  and the number of transfer batches  $NrSub$ ) is an important factor for the resulting costs

The introduction of routing variety has no effect on the selection of important factors in the design of a PBC system. However, the effect of more routing variety on the performance of the PBC system in terms of overtime and costs is considerable. The performance of the system becomes more sensitive for changes in the number of stages  $N$ .

The evaluation of the various configurations provides insights that we can use when we have to design a PBC system. This chapter has not tried to determine the best PBC configuration for the evaluated production situations. The simulation model is not an instrument in the design of a PBC system, but helps to determine the effect of various factors on system performance.

---

## Chapter 7 Determining a configuration of the PBC system

In Chapter Five we presented a progressive search heuristic for determining a configuration of a PBC system. This heuristic finds both an appropriate period length  $P$  and a suitable number of transfer batches at each operation (a variable subbatch strategy). The number of stages  $N$  follows from these parameter choices, as they determine the maximum throughput time of any of the products. The throughput time of the proposed PBC system is then equal to  $N \cdot P$ .

Chapter Five concluded that the progressive search heuristic performs quite well. The period length found by the heuristic remained in 92% of the experiments unchanged compared with the best solution found. However, the total costs of the configuration that was found by the progressive search heuristic could further be reduced by reconsidering the subbatch strategy.

These results for the progressive search heuristic were obtained for a number of random experiments based on the information from the example problem in § 5.5.1. This example problem has a simple structure, containing two products and a sequence of 8 or 9 operations per product. The example problem did not clearly resemble a cellular manufacturing system situation, as it did not distinguish cells, only operations.

In Chapter Six, we have considered a more complex production situation. We analysed the effects of various configurations of a PBC system with a fixed throughput time of 15 days. This analysis revealed that there are huge differences in performance between configurations with the same throughput time. The number of stages  $N$  and the equal subbatch strategy applied are the most important factors. Chapter Six used a time consuming simulation analysis to explore the effect of the various configurations on the amount of overtime work and costs. The simulation model provided a good representation of the production situation. However, it took 30 hours computing time to perform all simulations for the configurations with this single throughput time.

This chapter aims at determining a PBC configuration for a cellular manufacturing system with a more complex production situation than we considered in Chapter Five. Such a configuration includes a throughput time  $T$ , a period length  $P$ , a number of stages  $N$ , a decision about the stage contents, and a suitable subbatch strategy. Due to the complex relationships between the PBC design parameters, this is not an obvious problem. We might want to use the simulation model to evaluate several throughput times and determine appropriate PBC configurations. However, it will probably take too much time to perform such a simulation analysis for many different throughput times. We might also want to consider the possibility of using a search heuristic to determine an initial configuration of the PBC system for more complex production situations. This may require some modifications in the heuristic, as it has to cope with different input data structures. We therefore have to consider both the applicability of the heuristic and the suitability of a configuration that it proposes. We will restrict ourselves to the production situation I, discussed in Chapter Six.

We reformulate the question as follows:

*How can we use the progressive search heuristic in PBC system design, and what effect will it have on the performance of the PBC system for production situation I?*

The progressive search heuristic has been developed with a different purpose than the simulation model of Chapter Six. The proposed configuration consists of a variable subbatch strategy, while the simulation model allows only equal subbatch strategies. In order to test the outcomes of the heuristic, we will simulate the proposed configuration with our simulation model. Therefore, we need a procedure that translates the proposed configuration to a set of configurations that can be simulated in the model. Furthermore, the cost parameters in the simulation model have to be translated to suitable cost parameters in the progressive search heuristic in order to obtain a cost-effective configuration.

Appendix G proposes several modifications of both the heuristic and the input (cost) data in order to be able to use the results of the progressive search heuristic as input in the simulation model and to compare the results with other simulated configurations.

Section § 7.1 tests the proposed PBC configuration that results from the progressive search heuristic for production situation I. It describes the results of the progressive search heuristic and the application of this configuration in the simulation model of Chapter Six. The performance is compared with configurations that we tested in that chapter.

Section § 7.2 discusses the use of an initial configuration from the progressive search heuristic in the integral design of production and planning system. It uses the insights on the applicability of the progressive search heuristic in determining a configuration for the PBC system and develops a procedure for the integral design of both the production and (PBC) planning system. Finally, it pays attention to the value of the search heuristic in the design process. We present our conclusions in Section § 7.3.

## § 7.1 PBC configuration proposed by progressive search heuristic

We have used the data of production situation I, presented in Table 6.2 and Figure 6.9, as input for the progressive search heuristic. All three end products require 25 operations. The longest path starts for all three products with family B. There are only 12 operations on this longest path. Appendix G provides details on the procedure that we followed.

The 12 operations on the longest path require processing on machines in the sequence:

1 → 2 → 6 → 7 → 8 → 9 → 10 → 11 → 12 → 13 → 14 → 15.

The length of this path varies per product and depends on the batch size  $q_h$ . This batch size varies per period only if there is uncertainty of demand ( $AfwVol > 0$ ) and increases with the length of P. If there is no uncertainty,  $q_h = P \cdot D_h$ . Note that  $D_h$  is equal for all products. The length of the longest path for the three products is respectively:

Product	Length of longest path as function of batch size $q_h$
1	$200 + 97 \cdot q_h$ minutes
2	$200 + 98 \cdot q_h$ minutes
3	$200 + 104 \cdot q_h$ minutes

Other parameters for the progressive search heuristic are :

AfwVol		0	(i.e., constant demand of 5 items per order)
Volume		75	orders per $T=7200$ minutes
	$D_h$	375	items per 7200 minutes ( $Volume \cdot AfwVol = 75 \cdot 5$ )
Holding costs	$HC_h$	6.12/25	per item that remains $T=7200$ minutes in the system
Set-up costs	$SC_{hi}$	0.1	per minute set-up time
Transfer costs	$TC_{hi}$	0.1.25/12	per transfer batch ( $TC'_{hi} = TC''_{hi}$ )
MaxNrSub	$nb^{max}_{hi}$	4	(maximum number of transfer batches per period)
Machines	$m_{hi}$	1	(no identical machine available for operations)

### § 7.1.1 Results of progressive search heuristic without correction factor ( $MI = 1$ )

The progressive search heuristic calculates two lowerbounds on the length of P. Appendix G discusses the corrections necessary in these lowerbound calculations in order to accomplish for differences in modelling assumptions between the simulation model and the heuristic. It concludes that a correction factor  $MI < 1$  should be used in both lowerbound calculations. However, it does not provide a suitable value for MI. Therefore, we have first analysed the outcomes of the progressive search heuristic for a MI factor = 1. This will give us an indication of the required size of the correction factor.

For  $MI=1$ , the load oriented lowerbound in the progressive search heuristic gives us:  
minimum period length =  $0.1286 \cdot T$ , almost two days.

This load oriented minimum is caused by machine 3, which has a long set-up time, but is not on the longest path. A shorter period length would cause a utilization of this machine  $> 100\%$ . Higher volumes (e.g.  $Volume=90$ ) or a fluctuating demand ( $AfwVol > 0$ ) would result in a higher minimum period length.

Note that machine 3 does not remain bottleneck over the whole range of period lengths. Longer period lengths result in a diminishing set-up time effect at machine 3 and a faster increasing total processing time at machines with longer processing times per operation. This makes machine 13 bottleneck for longer period lengths than the load oriented minimum P.

The progressive search starts the search for a PBC configuration at the minimum period length with one subbatch per operation. The outcomes of the progressive search heuristic are:

$$P = 0.3767 \cdot T$$

$$N = 1$$

machine	1	2	6	7	8	9	10	11	12	13	14	15
<i>nb</i> (product 1)	2	2	2	2	1	1	4	2	2	4	4	1
<i>nb</i> (product 2)	1	2	2	2	1	1	4	2	2	4	4	1
<i>nb</i> (product 3)	2	2	2	2	2	1	4	2	2	4	4	1

The exhaustive search gives us the same value for P and N, but a different subbatch strategy that reduces costs. The proposed subbatch strategy of the exhausted search heuristic is:

machine	1	2	6	7	8	9	10	11	12	13	14	15
<i>nb</i> (product 1)	2	2	2	2	2	2	2	2	2	3	2	1
<i>nb</i> (product 2)	2	2	2	2	2	2	2	2	2	3	2	1
<i>nb</i> (product 3)	2	2	2	2	2	2	3	2	2	3	3	1

The subbatch strategy of the exhausted search heuristic almost reflects an equal number of subbatches strategy with  $nb_i=2$ . The bottleneck operation at machine 13 has a longer processing time and the heuristic chooses for each product a higher number of transfer batches at this operation. Product 3 has the highest expected throughput time, which is reduced with an increased number of transfer batches in order to avoid overtime work. The high loaded machines 10 and 14 use therefore one more transfer batch.

The heuristic advises not to use a total manufacturing throughput time of  $T=7200$  minutes, but to reduce this to  $P \cdot N = 0.3767 \cdot 7200 = 2712$  minutes, i.e. five and a half days. Within this throughput time, no further stages should be distinguished. Instead, at least two transfer batches per operation should be used. Relevant subbatch strategies are therefore  $nb=2$ , or 3. If only one transfer batch would have been used, the throughput time of product 3 would have become at least  $200 + 104 \cdot P \cdot 375 = 14891$  minutes (more than 31 days) at the proposed period length.

### § 7.1.2 Evaluation of proposed configuration in simulation model

We have tested this configuration in our simulation model. Parameters as Policy, Idd, and AfwVol have been fixed at their initial values Policy=FiFo, Idd=0, AfwVol=0 in all simulation experiments. The next values have been used for the other relevant parameters:

P	$0.3767 \cdot 7200$ minutes
N	1
NrSub	either 2 or 3
Volume	$0.3767 \cdot 75$ orders per $P \cdot N$ minutes = 28 orders
MI correction factor	1

The outcomes of the simulation for  $NrSub=3$  are presented in Figure 7.1. If we simulate with  $NrSub=2$  a similar pattern is obtained with somewhat more overtime work. The figure shows clearly that a considerable amount of overtime work results if we apply the PBC configuration that was proposed by the progressive search heuristic.

If we examine Figure 7.1 in more detail, we see that product 1 first enters the system and starts at time 0. This product is finished around 2630 minutes, i.e., within the period length  $P=2712$  minutes. The other products encounter a considerable start delay, which cannot be recovered during the period. This results in significant amounts of overtime work.

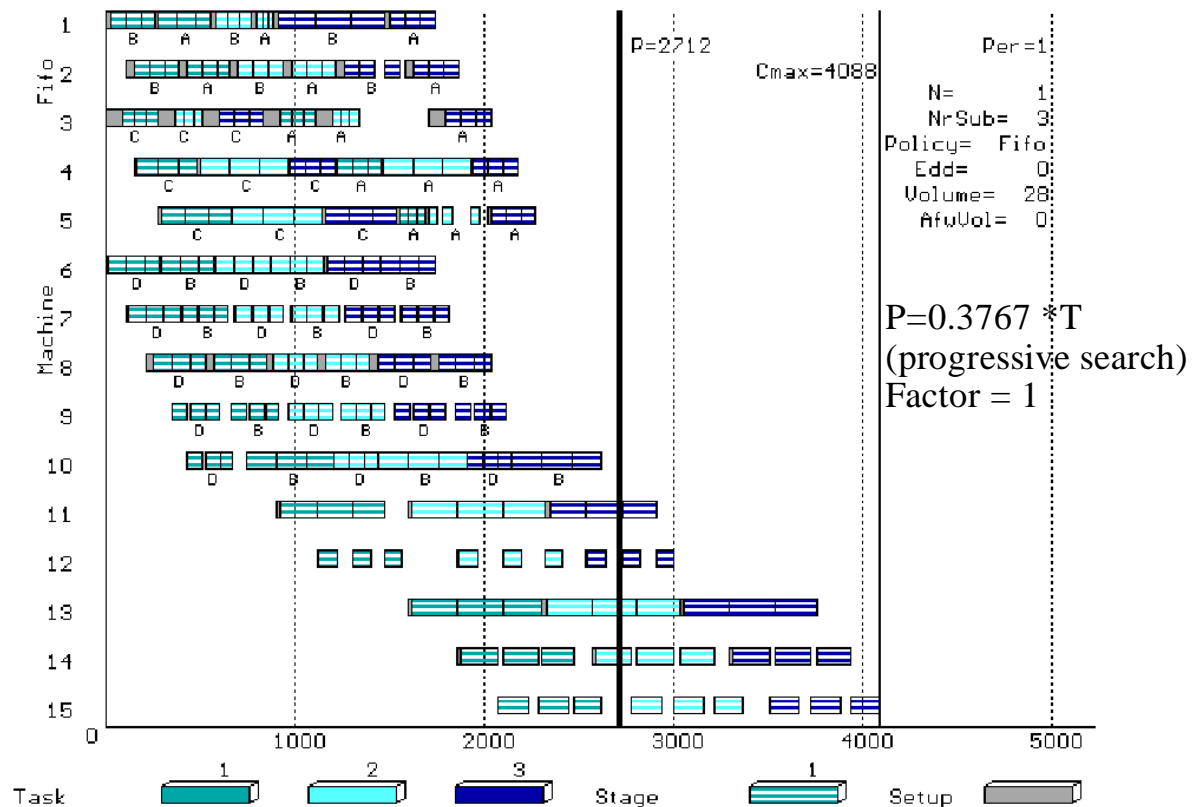

**Figure 7.1 Gantt chart for PBC design with  $N=1$ ,  $P=0.3767 \cdot T$ ,  $NB=3$**

In a flow shop structure as tested here, we expect this pattern of start/finish delays to occur. However, the progressive search heuristic that determines the PBC configuration does not presume this (extreme) production structure. It assumes that operations that require capacity at the same resource will not delay each other's progress, i.e. it ignores interactions between operations that do not belong to the same product routing. The simulation results show that the interaction between capacity usage and the timing of the operations has a strong effect on make span performance. This makes it necessary to correct the path oriented lowerbound with a correction factor  $MI < 1$ . Note that we also encounter delays on the longest path (family B) due to the performance of activities that are on a non-critical path (family D at machine 6).

The simulation model does determine the relevant cost factors for the proposed configuration. We can compare these cost factors with the costs of similar configurations with  $N \cdot P = T = 7200$ . There are two similar configurations possible with  $T = 7200$ . One with the same  $N$  and subbatch strategy as proposed, but a different  $P$ :  $P = 7200/N$ . The other configuration with a different number of stages  $N$  such that the resulting period length is nearest to the one proposed. The number of subbatches remains the same as proposed. Table 7.1 compares the results of the proposed configuration and the two similar configurations with  $T = 7200$  minutes.

Costs per 7200 minutes	Proposed configuration $N=1, P=0.3767 \cdot T,$ $NrSub=3$	Similar configuration $N=1, P=1 \cdot T,$ $NrSub=3$	Similar configuration $N=3, P=0.3333 \cdot T,$ $NrSub=3$
Holding costs	399	1092	822
Set-up+Transfer costs	297	112	337
Overtime costs	750	474	46
Total costs	1447	1678	1205

**Table 7.1 Comparison of the costs of proposed and original configurations with  $T=7200$**

The total costs of the proposed configuration consist for more than 50% of overtime costs. These costs were not counted for in the heuristic. Without these overtime costs, total cost would have been almost 697 for this configuration<sup>1</sup>. The total amount of overtime work is considerably higher than for similar configurations with a manufacturing throughput time of  $T=7200$  minutes. The cost of overtime work per 7200 minutes is for the new configuration 750 compared with 474 of the similar configuration with a much higher period length and identical number of stages and with 46 for the similar configuration with almost identical period length and higher number of stages. The total costs for the proposed PBC configuration are significantly smaller than for the  $T=7200$  configuration with equal number of stages ( $1678-1447=231$ ), but the  $T=7200$  configuration with equal period length results in a significantly lower total cost ( $1447-1205=242$ ).

The progressive search heuristic reduces the total manufacturing throughput time to almost 1/3 the original throughput time of  $T=7200$  minutes. This leads to a similar reduction of the work in progress and holding cost, and a corresponding increase in the set-up+transfer batch costs with a factor of nearly 3 (exactly  $1/0.3767$ ).

If we use  $NrSub=2$ , the configurations have higher total costs. The proposed configuration shows a cost of 1736, the similar configuration with  $P$  almost identical 1292 and with  $N$  identical 2021.

<sup>1</sup> Note that the costs that we report are obtained from the simulation model and reflect the average costs over 7200 minutes. This explains the difference between the holding costs and set-up+transfer batch cost for the proposed configuration. The solution that the progressive search heuristic finds generally has both cost types equally sized.

§ 7.1.3 Results of progressive search heuristic with correction factor  $MI < 1$

The main reason for the high costs for the proposed configuration is that we have underestimated the amount of overtime work. The flow shop structure in the data of production situation I is not recognized in our throughput time determination approach in the mathematical model behind the progressive search heuristic. It is possible to improve the estimation of the throughput time in the heuristic using some flow shop scheduling lowerbounds (e.g., adding the minimal remaining processing time at one of the machines to the calculated throughput time, see Riezebos, Gaalman & Gupta, 1995). However, we should recognize that a flow shop structure where each product visits the operations exactly in the same order is rather extreme, even in a cellular manufacturing situation. Therefore, we prefer a more flexible approach and apply a quick correction on the calculated throughput time estimation using  $MI < 1$ .

From Figure 7.1 we see that the final make span exceeds the estimated make span with more than 50% (2630 versus 4088). We need however not use a correction factor of 50%, as we also consider the correction on the lowerbound with respect to the load of the machines. We will start with correction factors of 5% and 10% and see what will be the effect on the required amount of over time work.

If we apply correction values for the lowerbounds of  $MI=0.95$  and  $MI=0.9$ , we obtain the configurations presented in the left column of Table 7.2. These configurations have been simulated. We present both the total costs and the overtime costs of the various configurations. The costs of the proposed configuration are in the columns labelled ‘proposed’, while the costs of the similar configurations with  $T=7200$  are in the next two columns. First, we present the results of a configuration with equal number of stages and a different period length, and next a similar value for the period length and a different number of stages. The value for the similar period length is presented in a separate column in the table. Figure 6.13 showed for all configurations with different  $N$  and  $NrSub$  that were considered. Note that all these configurations resulted in a throughput time  $T=7200$  minutes.

PBC Configuration						Total cost per $T=7200$			Overtime costs per $T=7200$		
MI	T	N	P	NrSub	Similar P value	Proposed	N equal	P equal to similar P	Proposed	N equal	P equal to similar P
1	2712	1	0.3767	3	0.3333	1447	1678	1205	750	474	46
1	2712	1	0.3767	2	0.3333	1736	2021	1292	1086	853	184
0.95	3826	2	0.2657	4	0.25	1060	1379	1365	0	0	7
<b>0.95</b>	<b>3826</b>	<b>2</b>	<b>0.2657</b>	<b>3</b>	0.25	<b>1023</b>	1369	1328	23	23	30
0.95	3826	2	0.2657	2	0.25	1075	1431	1303	134	121	68
0.9	4806	3	0.2225	4	0.2	1135	1207	1610	19	0	32
0.9	4806	3	0.2225	3	0.2	1108	1205	1554	60	46	51

**Table 7.2 Cost comparison for different values of lowerbound correction factor MI**

The results in Table 7.2 show that minimal total costs are obtained for  $MI=0.95$  and a PBC configuration with  $P=0.2657 \cdot 7200$  minutes,  $N=2$ , and 3 transfer batches per period. Figure 7.2 shows the Gantt chart for this configuration. The total manufacturing throughput time is  $N \cdot P = 0.5314 \cdot 7200$  minutes = 3826 minutes (8 days instead of 15 days). For this configuration, the minimal total cost per 7200 minutes is 1023. This is considerably lower than the minimal cost if a total manufacturing throughput time of 7200 minutes is used. Figure 6.13 shows that the minimum is then obtained at  $N=3$ ,  $NrSub=3$  with a cost of 1205. That makes a difference of 182 per 7200 minutes.

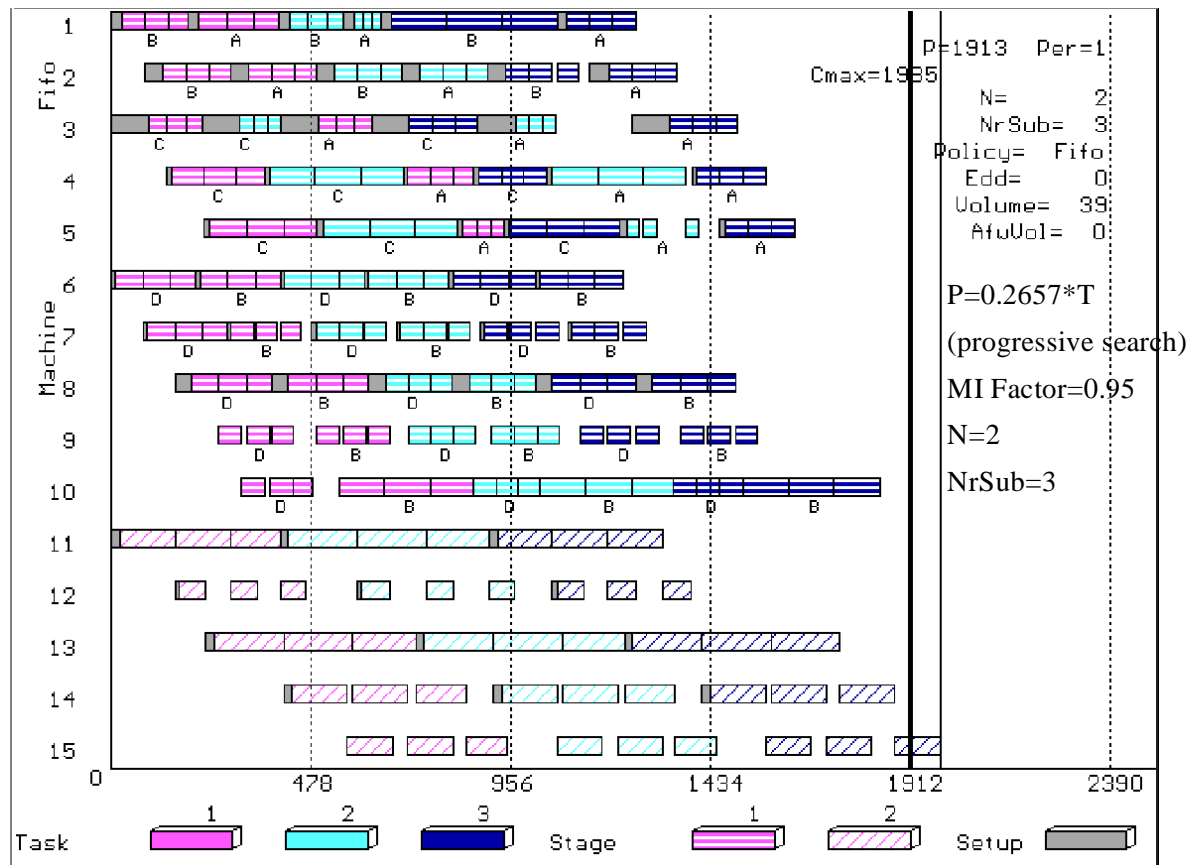

Figure 7.2 Gantt chart for minimal cost configuration of PBC:  $N=2$ ,  $P=0.2657 \cdot T$ ,  $NB=3$

This cost difference can be studied in more detail if we further look at Figure 6.13. The configuration that results in minimum total costs if  $T=7200$  has a holding cost of 822 (more than 68% of the total costs of 1205), the set-up and transfer batch costs are 337 (almost 28%), while the overtime costs are very low ( $46=4\%$ ). The proposed configuration that we obtained for  $MI=0.95$  has a minimum total cost of 1023, consisting of 56% holding costs (579), 41% set-up and transfer batch costs (422) and a very small amount of overtime costs (2%, 23). This configuration shows a better balance between holding costs and set-up + transfer batch costs.

Finally, we can see from Table 7.2 that the percentage of overtime costs in the total costs strongly decreases as the correction factor ( $1/MI$ ) increases. One reason is that the total manufacturing throughput time  $N \cdot P$  increases as well, which results in higher holding costs. The other reason is that the correction of the lowerbounds results in a better estimation of the required throughput time. This results in almost no overtime work in the system. As the costs increase for  $MI=0.9$ , we need not examine larger correction factors as well. However, we cannot easily predict at what value of  $MI$  the minimum cost will occur. This depends amongst other factors on the specific product structure.

From this analysis, we conclude that the PBC configuration resulting from the progressive search heuristic can be used to determine a suitable value for the period length  $P$  and number of stages  $N$  in a PBC system for production situation  $I$ . This configuration results in lower cost solutions than found with trial and error search procedures with  $T$  fixed at 7200 minutes. The proposed configuration determines a throughput time that is much lower than  $T=7200$ . For this configuration, we find a better balance between holding costs and set-up and transfer costs.

In order to be effective, the progressive search heuristic needs to include a correction factor  $MI < 1$  in the lowerbounds for the expected throughput time calculation. This reduces the amount of overtime work that will otherwise occur in the system.

The progressive search heuristic does not determine a suitable allocation of operations to the number of stages  $N$  that it proposes. It assumes a multi-phased PBC system, where an operation can start processing a subbatch after the preceding operation has completed it. In our simulation analysis we used the stage allocation of Chapter Six and tested the performance of the proposed configuration for this specific allocation. However, in general, we need to obtain a suitable stage allocation for proposed configurations with  $N > 1$ .

## § 7.2 PBC system design and the value of a search heuristic

We have shown that a search heuristic can be used in determining a configuration for a PBC system, as long as we correct for overtime and modify the heuristic such that it fits with the product structure. The question now rises how we can use a search heuristic in the design of a PBC system.

In order to answer this question, we consider the characteristics of the design approach that we proposed for the integral design of a production and planning system. In Figure 4.2 we presented such an approach. Figure 7.3 amplifies upon this approach, using the knowledge that we gained in the Chapters Four to Seven on PBC system design factors.

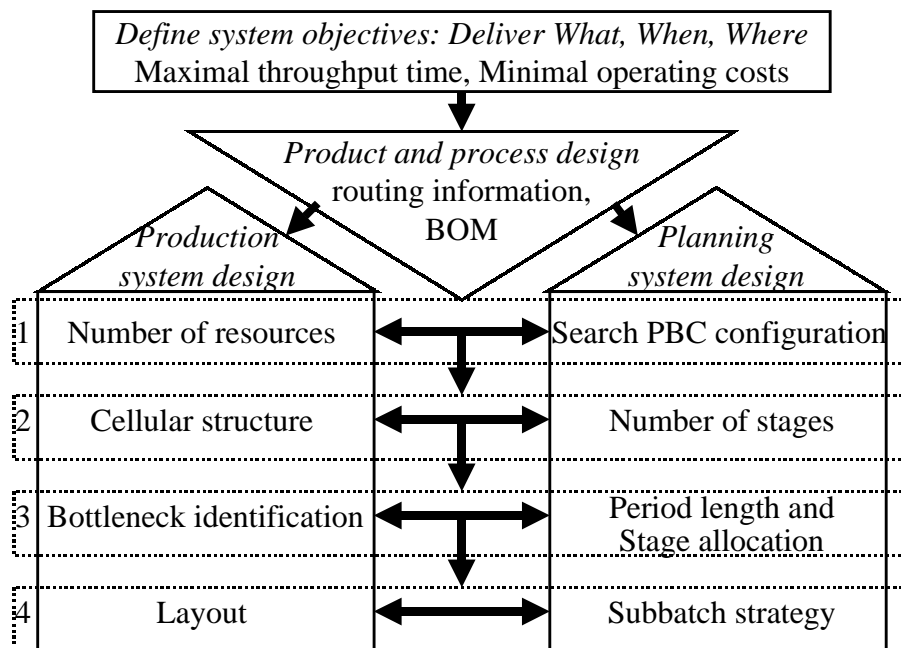

**Figure 7.3 PBC system design approach**

We start with determining relevant system objectives, such as minimal costs, and an acceptable range of throughput times. This enables us to determine the products and production activities that have to be considered in the system design. Therefore, we identify product structures (Bills Of Materials (Figure 6.9)) and routing information. This information is used as input for designing the production and the planning system.

The design of production and planning system shows a constant interaction, but can be divided into four main steps. The first step (1) consists of determining the elements of the production system (number of resources) and the characteristics of the planning system (initial values of  $N$ ,  $P$ , identification of longest paths, and subbatch strategies). We use the search heuristic to identify these initial values. This procedure does not require information on the allocation of operations to stages, cellular structure of the production system, or layout of the facilities. It only uses cost data, product and process data, and information on the number of resources in the production system. The output of the search heuristic can be used to reconsider the allocation of resources to the production system.

Next, the basic structure of both systems can be designed in step (2). Decomposing the production system into cells and defining the number of stages are parallel activities that influence each other, as discussed in Chapter Four. The number of stages  $N$  that is proposed by the search heuristic should be considered as a lowerbound on  $N$ . The cellular structure may make it necessary to use more stages. Furthermore, the impact of a single-phase PBC system is not taken into account in the proposed number of stages<sup>2</sup>. Therefore, the single phase loading of this system may lead to a higher number of stages than proposed.

<sup>2</sup> The heuristic assumes a multi-phased PBC system, even if it proposes to use several stages.

After designing the basic structure of both systems, decisions have to be taken in step (3) about the period length and hence about the throughput time of the products. These decisions have to be taken together with the definition of the stage contents, e.g., the determination of work orders per stage or allocation of operations to the stages. A trade-off has to be made between the length of the longest path (throughput time) and the load balance (bottleneck). We can use the framework for stage definition and the mathematical model that supports the decisions on stage allocation of Chapter Four. For this decision, we need information on the occurrence of bottlenecks in the production system.

The period length and total throughput time that resulted from the search heuristic should be reconsidered as well, especially if the number of stages has increased. We can use our simulation model to evaluate several alternatives. These alternatives can be generated using the insights from Chapter Four on specific period lengths that help to improve the learning capability of the production system or reduce the operating costs. The co-ordination requirements within and between the cells can be a significant factor in determining  $N$  and  $P$ .

The final step (4) is to determine an adequate layout within and between the cells. This decision influences the efficiency of the material flow system, which is very important in order to realise a specific subbatch strategy. Facilities of different cells that have to cooperate for performing operations on several longest paths need to be positioned such that the transfer of work can be performed without problem. The proposed subbatch strategy needs to be revised, as it has not taken into account either stage or cell boundaries. We possibly will prefer a lower number of subbatches at operations just before the boundary.

Concluding, we see the value of a search heuristic in providing a starting point for finding a configuration of a PBC system. It gives an indication for the minimal total throughput time, the number of stages, the length of the period, a suitable subbatch strategy for operations on the longest path, as well as the total costs in the system. Additionally, it provides a load oriented lowerbound on the period length  $P$  that assures that all operations do have enough remaining capacity available in order to perform their work. Literature on PBC system design omits such a starting point, as discussed in Section § 4.2.

However, the configuration that is proposed by a search heuristic should not be considered as a blueprint for PBC system design. The characteristics of the production system deserve a more important role in the final design of the planning system. Our design approach pays attention to this interaction.

The contribution of our design approach is that it considers the relationship between production system design and planning system design. The possibility of achieving system objectives with respect to throughput time, dependability, and costs, depends both on characteristics of the production system and the planning system. The value of the initial configuration produced by a search heuristic is that detailed knowledge on the product and process routings is included at an early phase in the design process.

### § 7.3 Conclusion

The PBC configuration for production situation I as proposed by the progressive search heuristic has been tested in the simulation model of Chapter Six. We had to modify several elements of the heuristic in order to make it possible to determine a configuration for the more complex input data structure of production situation I.

The tests with the proposed configuration without correction factor for the calculated lowerbounds showed a strong underestimation of the required amount of overtime work. A small correction factor (MI=95%) resulted in a more realistic configuration that showed a strong decrease in costs compared with configurations obtained with trial and error search procedures. We found a decrease in costs of at least 15% compared to the best solution found in the simulation study of Chapter Six.

The search heuristic can provide us with valuable information on an initial configuration of the PBC system. It gives an indication for the essential characteristics of the planning system, such as minimal total throughput time, number of stages, period length, longest path, and total costs. We would not like to consider the proposed configuration as a blueprint for PBC system design. The characteristics of the production system should play a far more important role in the final design of the planning system. Therefore, we propose four main steps in the integral design of production and planning system:

1. determining number of resources and initial configuration
2. determining basic structure of both systems
3. determining work orders, period length, throughput time using information on bottlenecks
4. determining lay-out, material flow, and subbatch strategy

In the next chapter, we will further explore characteristics of the production system that should be taken into account in the design process. We will discuss the effect of PBC system design choices on the logistical co-ordination in a cellular decomposed production system that still has to be performed when PBC is used for the overall goods flow planning.

---

## Chapter 8 Co-ordination between cells and PBC system design

PBC system design influences the required co-ordination between cells. PBC performs the overall co-ordination of the material flow through the logistic chain of the firm. The design of the PBC system determines the frequency of planning, progress control, forecasting. It also determines the horizon of planning and forecasting. Finally, it determines the contents of work orders that are released to the stages.

Not all necessary logistical co-ordination is being performed by PBC. First, the cells have to co-ordinate several activities that they have to perform in order to complete the work package that PBC releases to the floor at the start of a period. Second, co-ordination between cells within the same stage might also be required. If cells are sequentially or simultaneously related within the same stage, these relationships generate co-ordination requirements. PBC does not accomplish for this co-ordination.

The amount of co-ordination effort depends on the system objectives as well as the design of both the production and planning (PBC) system. We will call this *remaining* logistic co-ordination, in order to distinguish it from the co-ordination effort required for operating the PBC system, such as forecasting, information gathering, and periodic work order release.

Consequently, PBC system design results in a hierarchical decomposition of the planning and control system. The upper hierarchical level consists of decisions for the current execution period, as we have illustrated in Figure 3.9. Examples of these decisions are the determination of a sales plan for the first unplanned sales period (N periods ahead), the adaptation of capacity levels for intermediate stages, and the release of work orders for the current period.

The lower hierarchical level of the planning and control system consists of decisions regarding the remaining logistic co-ordination in the current period. These decisions concern both processes that are located within cells and between cells. The co-ordination effort at this level depends also on the design of the production and planning systems and the congruity of these designs. Production system design determines cell boundaries and planning system design determines stage boundaries, period length and number of stages. Chapters Four and Seven showed that these decisions are interrelated and jointly affect the amount of remaining co-ordination between cells at the lower hierarchical planning level.

This chapter studies the relationship between PBC system design and the co-ordination between cells at the lower hierarchical planning level. Section § 8.1 will examine the influence of PBC system design on uncertainty in a cellular manufacturing system. This uncertainty determines the remaining co-ordination requirements within and between cells. Section § 8.2 discusses the allocation of co-ordination tasks and responsibilities in the planning system and provides an architecture for stage co-ordination and its relationship with cellular control. Section § 8.3 summarizes our conclusions.

The chapter aims at providing further insight into the characteristics of the cellular decomposed production system and the consequences of PBC system design choices for the co-ordination between the cells.

## § 8.1 Effect of PBC system design on uncertainty in a cellular system

The central question in this section is to what extent PBC system design choices have an effect on the uncertainty in a cellular system. In order to answer this question, we will assume that the system objectives are known as well as the cellular structure of the production system. We are interested in the type of uncertainty that influences the possibility of reaching the desired mix of system objectives. Therefore, we will first explore the type of uncertainty that cells face.

### § 8.1.1 Uncertainty in cellular manufacturing systems

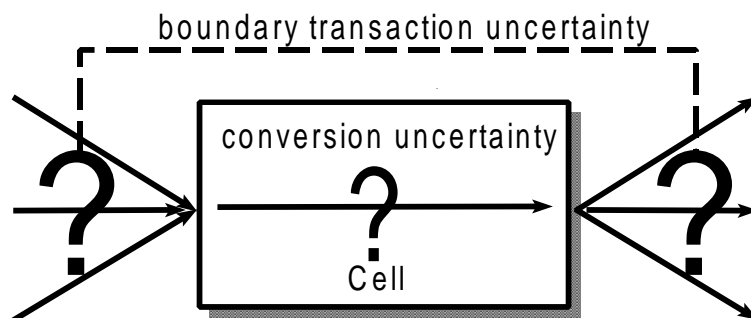

**Figure 8.1 Uncertainty influencing remaining co-ordination in cellular manufacturing**

Cells have to perform several activities in order to complete the work package that is being released from the PBC planning system. They need material, information, and instructions from other parts of the system in order to fulfil their task and complete the work package within a period. Hence, we see that cell performance depends on the availability of these inputs. Other parts of the system may demand outgoing flows of this cell. If these flows do not actually occur because the external party does not start moving the produced items, this may influence the performance of the cell. Susman (1976) introduced the term *boundary transaction uncertainty* to describe this type of uncertainty.

*Boundary transaction uncertainty* considers three facets of uncertainty in the relationship of a cell with other parts of the system. We call these facets Timing, Location, and Specification:

TIMING	WHEN	will incoming and outgoing (goods, resource, or information) flows cross the (cell) boundary?
LOCATION	WHERE	will these flows cross the (cell) boundary?
SPECIFICATION	WHAT	will be the specifications (quality and quantity) of the output?

If a cell would face no boundary transaction uncertainty that originates from relationships with its environment, it could still face uncertainty that influences its performance. This type of uncertainty is denoted as *conversion uncertainty*.

Conversion uncertainty concerns the way to deal with the required transformation *within* the cell. In addition to the timing, location, and specification of this transformation, uncertainty can exist on HOW the product has to be made and by WHOM. The selection of processing equipment, tools, operators, measurement methods, inspection procedures for inputs and output, and the determination of the sequence of activities that are required for the operation, influences the performance of the cell. Conversion uncertainty therefore considers how to convert these inputs into the desired output. The desired output not only refers to the product specification, but also to the system objectives cost, quality, speed, and so on.

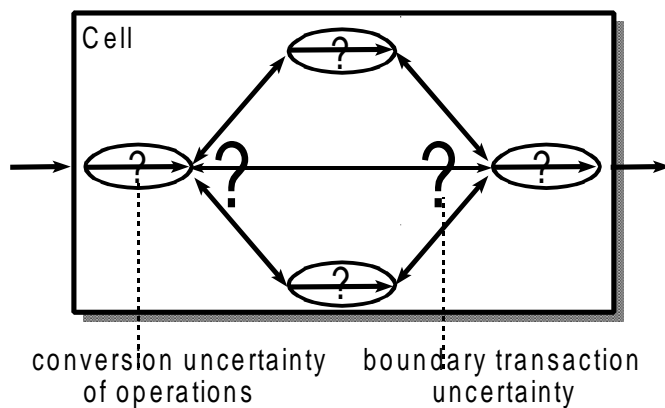

**Figure 8.2 Uncertainty within cells**

Figure 8.1 showed conversion uncertainty at cell level, where the cell is considered to be a black box. In Figure 8.2 we have opened the black box of the cell and again we find conversion uncertainty, which is now intrinsic to the required *operations* instead of the *complete transformation*, and boundary transaction uncertainty, now with respect to the availability of internal cell flows in order to perform these operations.

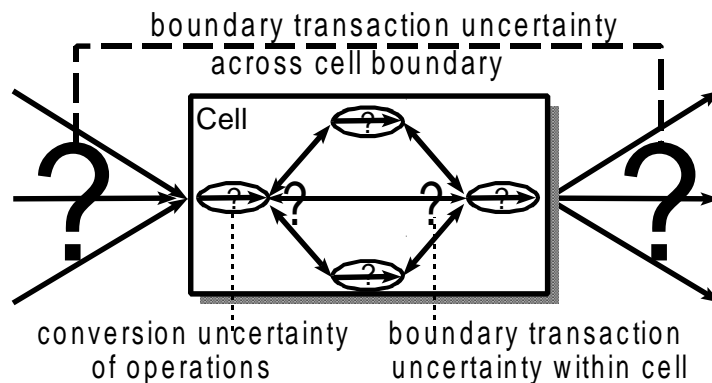

**Figure 8.3 Three components of uncertainty in cellular manufacturing**

We conclude that the source of uncertainty within cells can be decomposed into three components, as shown in Figure 8.3: boundary transaction uncertainty across the cell boundary, boundary transaction uncertainty within the cell, and conversion uncertainty with respect to the operations that have to be performed.

First, we will explore the effect of PBC system design on the conversion uncertainty and boundary transaction uncertainty *within* the cells. Sections § 8.1.2 and § 8.1.3 will pay attention to the effect of determining period length, number of stages and stage allocation on respectively this conversion and boundary transaction uncertainty.

Section § 8.1.4 will examine the effect of PBC system design on boundary transaction uncertainty across the cell boundary. There we will discuss the remaining co-ordination requirements *between* cells. It is necessary to examine both the co-ordination within and between cells in order to understand the consequences of changes in PBC system design choices. It considers both sequential and simultaneous relationships between cells and consequences of these relationships for the remaining co-ordination effort.

Section § 8.1.5 considers the ability to exploit latent relationships between cells for different PBC design choices. Finally, Section § 8.1.6 studies the relationship between the uncertainty in the system and the selected co-ordination mechanisms.

### § 8.1.2 Conversion uncertainty

The effect of PBC system design on conversion uncertainty within cells will be discussed separately for the three main choices in PBC system design: period length, number of stages, and stage allocation. In our conclusions on the effect of changes in one of these PBC system design choices, we assume that the mix of system objectives has not changed.

#### *Period length*

The length of the period has an important effect on the sources of conversion uncertainty. Susman (1976) already pointed towards the effect of a longer period when searching ways to cope with the inputs and to perform the transformation. He stated [1976: 96]: *'It is presumed that the longer the time available to organizational members to search for activities to convert input properties, the greater the likelihood that appropriate activities will become known to them'*. A longer period length clearly allows more time to determine a way to perform the transformation. Both in the preceding stages (preparing process plans in the ordering stage) and in the production period itself is more time available, which might lead to a reduction of conversion uncertainty.

However, shortening the period length might lead to the same result: a reduced conversion uncertainty. Shorter period lengths make it less necessary to introduce overlapping production, as we have shown in Chapter Six. Therefore, shorter periods make it easier to

allocate several successive operations (both production and preparatory tasks) to the same operator. Shorter periods might result in more variable and possibly longer work cycles for the operators, which eliminates one of the sources of conversion uncertainty, namely incomplete and erroneous specified work transfer. The reduced monotony of work might further lead to improved awareness of the characteristics of the task that is being performed, which again reduces conversion uncertainty.

Furthermore, shorter periods in combination with recurring (non-lumpy) demand results in an increase in repetition of work cycles. Repetition facilitates the process of continuously improving cell performance. This is a process of learning that obeys the general principles of learning processes as described in, for example, Senge (1990). We do expect advantages for the cells due to the application of more stable schedules and work patterns if repetition occurs. The schedule robustness allows a focussed effort to further reduce sources of conversion uncertainty that distort the desired system performance (e.g., costs, quality, and yield).

Concluding, we see that the length of period has a diffuse effect on conversion uncertainty within cells. If the repetition of product demand in the system is high (no lumpy demand in a basic unicycle PBC system), benefits of shorter period lengths with respect to a reduction of conversion uncertainty will probably exceed the benefits of longer period lengths. The latter will be more important in case of high demand variety and low repetition.

#### *Number of stages*

A higher number of stages reduces part of the conversion uncertainty. An increase in  $N$  increases the order throughput time. This gives more time to perform preparatory activities for operations that are delayed because of the increase in  $N$ . Part of the conversion uncertainty is therefore reduced. However, conversion uncertainty that is intrinsic to the resource that will be used for performing the operation is not influenced by a change in the number of stages.

#### *Stage allocation*

The allocation of operations to stages can exactly reflect the decomposition of the production system into cells. Such an allocation results in identical release and due dates for all work orders, where all operations that have to be performed within a cell belong to this work order.

If instead of this allocation, a situation arises with more cells being active in a stage (see Section § 4.4.2), some work orders may encounter smaller time windows in which the same operations have to be completed. This may restrict the search of the cell for the optimal mix of operator(s), tools, processing equipment, and so on, in order to perform such operations. We have discussed this extensively in Chapters Five and Six with our load oriented approach. Sequential relationships between cells within a stage restrict therefore the possibility to find the best way to perform the transformation process within a cell. In addition to the restricted availability of resources, material, and so on, within the smaller time window, we may also encounter a reduced search time for finding the best possible way of performing the

transformation during the period. Hence, stage allocations resulting in sequential relationships between cells in a stage cause an increase in conversion uncertainty within a cell.

If instead a reallocation of operations would be applied that results in a cell becoming active in more stages, we may encounter a reduction of sequential relationships between operations in a stage. If operations that were formerly performed within the same stage are allocated to different stages, this provides more degrees of freedom for the cell to schedule the various activities. As a result, we see a reduction of conversion uncertainty, because there are less restrictions on the timing of the activities within the period and hence more alternatives in the selection of processing equipment, and so on. Hence, a stage allocation that reduces sequential relationships between operations results in less conversion uncertainty.

### § 8.1.3 Boundary transaction uncertainty within cells

In this section, we will discuss the effect of varying the PBC system design parameters on the boundary transaction uncertainty within cells. We will assume that there is no boundary transaction uncertainty across the cell boundary. Note that boundary transaction uncertainty within the cell exists only if we encounter sequential relationships within a cell. These sequential relationships may concern material (i.e., goods flow between operations), tools, resources, or information. Hence, we assume that such relationships exist if we consider the effect of varying system parameters on this type of uncertainty.

In order to understand the causes for boundary transaction uncertainty, we have to make a distinction between the timing, location, and specification aspects. Causes for the timing facet (WHEN) of boundary transaction uncertainty can be identified by examining the queuing characteristics of the system. We distinguish between:

*resource availability*      the next processing step can only continue if the required resource has become available, which generally takes some waiting time because of the desired utilization of the resource

*also known as*      *congestion waiting time*

*input flow availability*      the next processing step can only continue if the last of all preceding incoming flows have become available

*also known as*      *assembly (or touringcar) waiting time, completion delay*

*periodic service*      the next processing step can only continue at specified moments in time and the input flows are generally present some safety time before this moment

*also known as*      *(train) platform waiting time*

The boundary uncertainty with respect to *resource availability* increases if we encounter higher utilization rates. The higher mean waiting times that are required in order to achieve higher utilization rates do in itself not result in an increase in uncertainty, but higher utilization rates also result in a higher variance of this waiting time (Bertrand, Wortmann, Wijngaard [1990a:178]). The higher variance results in less dependability towards the next processing step within the cell and therefore in higher boundary transaction uncertainty with respect to the timing facet.

Boundary transaction uncertainty with respect to *input flow availability* from preceding operations within the cell increases with the number of flows that have to be available before the next operation can start. The operation waits until the last input flow is available, hence its waiting time is a function of the maximum of the independent waiting times. The variability increases with an increase in the uncertainty in the independent waiting times, which again depends (among other things) on the utilization rates of resources that perform the operations.

Finally, we consider the effect of *periodic service* on boundary transaction uncertainty. An increase in the frequency of these services, for example transportation to the next operation, reduces the mean and variability of the waiting time and hence of the boundary transaction uncertainty between operations.

The location and specification facets of boundary transaction uncertainty play a less prominent role in cellular manufacturing systems compared with functional organized systems. The reason for this is the geographical closeness of successive operations, which results in less uncertainty on the location of materials, tools, and information. For the same reason, it is also easier to communicate on the required specification within a cell. These facets of boundary transaction uncertainty are therefore not primarily influenced by PBC system design decisions as long as a cellular system is used. In Section § 8.2, we will show that the allocation of responsibility for planning decisions in the system indirectly influences this type of uncertainty, but first, we will discuss the direct effect of varying the PBC system design parameters on the boundary transaction uncertainty within cells.

#### *Period length*

Increasing the period length results both in larger batches and in more time available for completing the set of work orders. For relatively short paths (time required for a sequence of operations), this increase will result in larger blocks of slack time, which reduces the boundary transaction uncertainty and simplifies the sequential co-ordination. For relatively long paths, it becomes more difficult to finish the whole batch within one period, as we have shown in the anomalous effects in Figure 6.6 and Figure 6.7. Therefore, an increase in the length of the period results in an increase in boundary transaction uncertainty for these work orders and hence a shift of co-ordination effort towards the work orders with longer paths. This same shift will occur for work orders with a higher probability of exceeding the due date, for example, because of high assembly waiting times. Within PBC, these orders should

receive priority over less urgent orders. Hence, increasing period lengths require an acceleration / retardation approach, as proposed by Van de Wakker (1993). Burbidge (1988) presents such a detailed co-ordination approach that schedules and controls critical operations closely during the whole period, while operations with more slack time receive less detailed co-ordination.

#### *Number of stages*

A higher number of stages increases the order throughput time, but does not result in a change in co-ordination requirements for boundary transaction uncertainty between operations, unless the allocation of operations to stages changes.

#### *Stage allocation*

Operations that have to be performed successively in the same cell can be allocated to different stages instead of the same stage. This results in a reduction of boundary transaction uncertainty between these operations. The next operation is safeguarded from the input flow availability waiting time, as the PBC system synchronizes these production activities. There is also less necessity to apply overlapping production if successive operations are allocated to different stages. The boundary transaction uncertainty that is caused by waiting time for periodic service therefore also diminishes.

### § 8.1.4 Boundary transaction uncertainty across cell boundaries

We will now focus on the effect of PBC system design choices on the boundary transaction uncertainty between cells. This type of uncertainty exists only if we encounter relationships between a cell and its environment. These relationships may concern material (goods flow), tools, resources, or information. Hence, we assume that such relationships exist if we consider the effect of varying system parameters on this type of uncertainty.

Co-ordination requirements across cell boundaries partly originate from the interdependency between cells, as there are also other elements in its environment. We will focus on the interdependency between cells. In Chapter Two, we introduced three types of relationships between cells: sequential, simultaneous, and latent relationships. From the three PBC system design choices, stage allocation causes sequential and simultaneous relationships to occur. We will therefore explore for these two relationships the influence of stage allocation on the boundary transaction uncertainty between cells. Latent relationships will be discussed separately in the next subsection. First will we discuss the effect of period length and number of stages on this type of uncertainty.

*Period length*

The length of period influences the boundary transaction uncertainty between cells. Each cell obtains all relevant information on the complete work order package at the start of the period. If the length of the period increases, the probability that this information is incorrect at the time of use increases. This might have consequences for the quality of decision making within the cell with respect to subcontracting operations, rerouting work to another machine, or hiring extra workers. Consequently, it might increase the boundary transaction uncertainty across the cell boundary.

Longer period lengths might make it easier to co-ordinate the use of shared resources by different cells. It becomes more easy to allocate several parts of the period for operations of cell I and other moments for cell II, because of the shift in co-ordination effort towards an acceleration/retardation approach that we have described in § 8.1.3. The work orders that require co-ordination that is more intensive can be treated separately.

*Number of stages*

Increasing the number of stages without reallocating the operations does not lead to a change in boundary transaction uncertainty between cells.

*Stage allocation*      *stage allocation exactly reflecting the cellular decomposition*

If the stage decomposition exactly reflects the cellular decomposition (see the discussion in Section § 4.4), then all work orders that are released to the cell have identical release dates and due dates. The sequential relationships between cells will not concern the intercellular goods flows but only the intercellular flow of tools, resources, or information required to proceed with the transformation process. If there is no intercellular goods flow within a stage, the advantages for cell scheduling are mainly a reduced boundary transaction uncertainty:

- ◆ the cell faces less uncertainty with respect to the arrival of work orders
- ◆ the cell faces less uncertainty due to the fact that required departure times of work orders within the period do not vary
- ◆ the dependency of the internal schedule generation process from decisions of other cells is restricted to the planning of tools flow, resource flow, or information flow (again less boundary transaction uncertainty)

*stage allocation resulting in simultaneous relationships between cells*

Simultaneous relationships result in cells that perform in the same period activities for the same end product. The activities in itself are not related (for example, the production of a tool and the preparation of an accompanying direction for use), but both activities will be influenced by decisions concerning the order (e.g., cancellation). The internal co-ordination in the cell can benefit from the availability of information from the other cell on the progress of the order in determining priority between orders. Therefore, simultaneous relationships between cells within a stage influence the boundary transaction uncertainty between cells.

Cells can decide to allocate simultaneous related operations to different stages. The only change in uncertainty that we expect from this decision is a reduced sensitivity for mix variation, which causes a reduction of boundary transaction uncertainty between cells compared with an allocation of these operations to the same stage.

*stage allocation resulting in sequential (goods flow) relationships between cells*

If cells are sequentially interdependent within the same stage because of an intercellular goods flow, both cells face boundary transaction uncertainty. The first cell in sequence faces demand (output) uncertainty, while the last cell in sequence faces input uncertainty, as can be seen in Figure 8.4. The two sequentially interdependent cells in the same stage have to determine an internal transfer date of the work orders that have to be finished within the same period. If the PBC system should provide this sequential co-ordination, an operation reallocation would be required that might have consequences for other cells as well, leading to a shift in the interdependencies between cells.

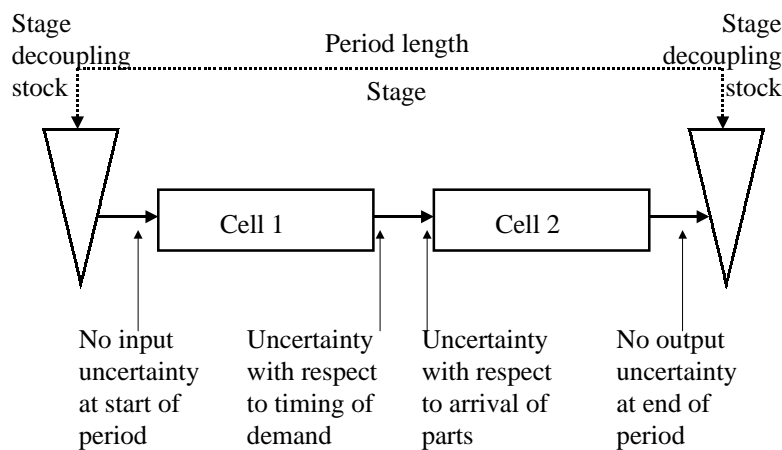

**Figure 8.4** Uncertainty caused by sequential relationship between cells within stage

### § 8.1.5 PBC design and latent relationships between cells

A latent relationship between cells exists if flexibility is available in the production system that can be used to create or change a sequential or simultaneous relationship between cells. It describes opportunities of the system to change relationships between cells. PBC system design choices affect the possibility of the system to use these latent relationships.

#### *Period length*

If the period length increases, the PBC system loses control over the exact state of the production system. It cannot predict where problems will occur and hence it is more difficult to use the latent relationships between cells at program meetings when plans for the next period are being determined.

*Number of stages*

An increase in the number of stages increases the foresight of the planning system. If problems are foreseen with availability of capacity one or more periods ahead, an increase in  $N$  will result in either more preparatory time available, or more precise knowledge of the moments these problems will occur. Hence, an increase in  $N$  has effect on the possibility of using latent relationships between cells and developing alternatives for the typical sequential and simultaneous relationships between cells in the system.

*Stage allocation*

A different stage allocation also affects the use of latent relationships between cells. The timing of specific operations is influenced by this allocation and hence the use of resources within a period. The availability of alternatives for the selected resources during this restricted period depends on the allocation of these and other operations to the stages.

### § 8.1.6 Uncertainty and co-ordination requirements

PBC system design choices (determining  $P$ ,  $N$ , and stage allocation) affect the uncertainty in a cellular manufacturing system.

A change in the length of period has a diffuse effect on the conversion uncertainty within cells. It depends on the degree of repetition of product demand if either reducing or increasing the period length reduces conversion uncertainty within cells. The boundary transaction uncertainty within cells shows the same diffuse pattern. Increasing the period length results in less boundary transaction uncertainty for work orders with short paths, but more transaction uncertainty for work orders with long paths. Therefore, a change in period length makes a shift in co-ordination requirements necessary in order to cope with boundary transaction uncertainty within the cells. The same holds true for the boundary transaction uncertainty between cells. In general, this transaction uncertainty increases with a higher period length

An increase in the number of stages might result in a decrease in conversion uncertainty, but does not influence boundary transaction uncertainty, neither within or between cells, unless the allocation of operations to the stages changes.

If the stage allocation resembles the cellular structure, we might encounter within a stage more sequential relationships between operations that have to be performed in the same cell and less sequential relationships between cells during a period. This allocation therefore results in relatively more conversion uncertainty and boundary transaction uncertainty within the cells and less boundary transaction uncertainty across the cell boundary. Alternative allocations might either result in more relationships between cells in a stage or more operations of a cell in different stages. The latter case results in the least uncertainty within

the system, as it introduces the largest amount of slack time within the product routings and lets PBC perform the required sequential co-ordination within the system.

We conclude that PBC system design affects the uncertainty within a cellular manufacturing system. In order to cope with the resulting uncertainty, we have to design appropriate co-ordination mechanisms. The design of the PBC system influences this process of designing co-ordination mechanisms as it decides on the nature, strength, and location of interdependency in the manufacturing system. It depends both on the desired mix of system objectives and on the possibility of applying specific co-ordination mechanisms between cells whether stage boundaries should reflect cell boundaries or preference should be given to alternative stage decompositions. Therefore, PBC system design clearly affects the co-ordination requirements between cells.

In the next section, we will explore the consequences of this distribution of uncertainty for the design of the planning system. As PBC will only be part of this total planning system, many of the co-ordination requirements in the cellular system have to be accomplished for at another part of the planning system. We introduce the notion of stage co-ordination to reflect this.

## § 8.2 Stage co-ordination as part of the planning system

PBC system design affects the distribution of uncertainty in the manufacturing system. The design can attempt to distribute uncertainty mainly within the cells and not between cells in a stage. For such a distribution of uncertainty in the system, we might prefer a high autonomy of cells. A high autonomy implicates the delegation of authority and responsibility with respect to decisions on the way to handle the uncertainty.

Alternative designs of the PBC system might result in different distributions of uncertainty. The decision about stage allocation can result in boundary transaction uncertainty between cells within a stage. This type of uncertainty need not diminish by creating relatively autonomous cells. Therefore, literature on socio-technical systems design (e.g., de Sitter, 1998, Kuipers & van Amelsvoort, 1990) incorrectly assumes that delegating authority and responsibility towards cells is necessary to reduce uncertainty and obtain the benefits of cellular manufacturing systems. Susman (1976) offers a more balanced view on this distribution of regulatory decisions in the planning system.

If we prefer a design of the PBC system that results in boundary transaction uncertainty between cells within a stage, we have to cope with the co-ordination requirements that result. The presence of sequential relationships between cells within a stage makes it necessary that the goods flow between the cells within a period has to be co-ordinated as well. The basic unicycle PBC planning system does not make a distinction between work orders that have to

be processed in only one or in several cells. The absence of support for the co-ordination between cells within a stage might lead to a reduction in the overall performance of the production system. This loss in performance is also indicated by Steudel & Desruelle [1992: 295]. Therefore, we will pay attention to the co-ordination between cells within a stage.

### § 8.2.1 Stage co-ordination

Stage co-ordination might provide the co-ordination requirements between cells during a period. In our simulation experiments in Chapter Six, we have tested a stage co-ordination policy (IDD) that uses intermediate due dates for work orders that visit more cells within a stage. The use of these intermediate internal due dates did not improve the dependability of the system. This may partly be due to the specific production structure of the simulated cellular manufacturing system. Hence, other stage co-ordination policies may perform better.

We have searched in literature on planning system design for an appropriate design of stage co-ordination. The framework of Bauer et al. (1991) introduces an intermediate hierarchical co-ordination level between the (MRP like) central planning system level and the decentral cell control level. They denote this new level as *factory co-ordination* and state that '*if the individual cells were autonomous, factory co-ordination would be unnecessary*' [1991:31]. However, in typical manufacturing plants '*the control task within factory co-ordination organizes the flow of products between all cells within a factory. The control task can be complex because of the various production constraints and manufacturing goals which relate to the entire manufacturing system. Issues such as delivery dates, work in progress levels, and utilization on capital intensive equipment, combined with manufacturing goals such as maintenance of high product quality and decreased product lead times too present a series of conflicting objectives which require trade-offs*' [1991:83]. The distinction that Bauer et al. make between the central planning system level and factory co-ordination is interesting. They do not offer a systematic treatment of the differences in planning decisions that have to be performed at these levels. Neither do they describe policies that can be applied at factory co-ordination level. From their description of factory co-ordination, we deduce that important facets of factory co-ordination are:

- 1 real time control within planning period (shorter reaction time than central planning)
- 2 context specific (relationships between cells that have to be co-ordinated are situation specific)
- 3 platform for mutual adjustment between cells in order to trade-off conflicting goals

If we look at this short list of facets of factory co-ordination, we see that these tasks generally belong to the task domain of a production planning function within an organization. The task domain of a planner that performs these tasks consists of the following:

First, the planning function transforms demands for end products into material requirements per period, orders new material, checks on the availability of capacity and input material, determines production orders and appropriate due dates for these orders. For these tasks, generally a central planning system is being used. These tasks belong to the *preparation of a plan*.

Next, the planning function is concerned with the *execution of this plan*. Work orders have to be released to the production system, the progress of the plan has to be supervised, problems that occur in the progress of the plan have to be identified, measures that might improve the progress of the plan have to be taken, and the mix of objectives for the production system with respect to this plan has to be communicated.

Takkenberg (1983) calls the second facet of the task domain of the planning function '*decision-making during the execution of a plan*' and he defines this control as: '*the supervision of the execution of the plan between two subsequent planning moments*' [1983:50]. The decision-making is directed towards obtaining the original planned objectives for the various system outputs. The plan is used as guidance in this decision making process. The mix of objectives reflects the trade-off that has been performed within the planning process and this mix should therefore be obtained within certain margins.

We can now return to the contents of factory co-ordination, as introduced by Bauer et al. (1991). In their view, the task domain at central planning level is restricted to the preparation of the plan. Note that this phase may include activities with respect to the ordering of material with suppliers, preparation of subcontracting, and so on. However, these activities are performed before work is released to the production system. The output of the central planning level is a list of work orders and their due dates. This is all comparable to PBC planning.

The translation of the central plan to the measures required for an adequate realization do not belong to the task domain of a production planner at central planning level. We denote the next co-ordination level as stage co-ordination<sup>1</sup>. It provides the remaining co-ordination between cells that are planned with a PBC system. The task domain of a planner at stage co-ordination level consists of what we have called the execution of the central plan. This execution has to be performed in accordance with the specific structure of the production system (e.g., degree of autonomy of cells). The contents of the control efforts cannot be determined in advance, but depends on the situation that occurs within a period. The loading and capacity of the cells varies per period. Loading variations may for example be caused by yielding problems, demand variations, lot sizing decisions, and so on. Capacity variations may be caused by, e.g., illness of work force, or maintenance of resources. Furthermore, the

---

<sup>1</sup> Stage co-ordination is not identical to factory co-ordination as presented in Bauer et al (1991). Stage co-ordination does not distinguish a production environment design task at this layer of control, and gives more attention to the co-ordination requirements due to the stage decomposition of PBC.

PBC plan may require the use of transfer batches between cells. These circumstances ask for specific measures with respect to the co-ordination between cells. Stage co-ordination has to provide this facet of central planning.

The task of stage co-ordination may well be performed without allocating formal decision authority to one planner. A stage co-ordination planner might function appropriately at a liaison position between the cell controllers, as the effectiveness of the co-ordination is based on sharing information between the various cell controllers and the central planning. Formal decision authority at one central position does not guarantee a high quality of the decisions.

Stage co-ordination may still be required if stage boundaries exactly reflect cell boundaries. Adjustment mechanisms for the central plan may be required even if there are no planned material flows between cells within a planning period. We can still face latent relationships, uncertainty, unexpected circumstances, and resource or information flows between cells that may require co-ordination and supervision. Only in case of purely autonomous cells, such co-ordination is superfluous, as indicated in the citation from Bauer et al [1991:31].

We conclude that the distinction between a central planning level, a central stage co-ordination level and a decentral cell control level can be useful, although we want to stress that the distinction between both central (or upper) hierarchical levels is somewhat artificial.

### § 8.2.2 Functional architecture of stage co-ordination within PBC planning

The decomposition of the total planning and co-ordination task in these three task domains has important consequences for the performance of the total system. We agree with Habich [1990:39] who states '*Die Aufgabe der zentralen Systementscheidungskoordination besteht darin, einzelne, kundenbezogene Fertigungsaufträge fertigungs- und montagegerecht zu synchronisieren und in der Gesamtzielsetzung entsprechende Inselaufträge zu dekomponieren*'. In case of relatively autonomous cells, the detailed scheduling decisions with respect to the work orders in the cells are often decentralized. A cell scheduler decides on the time at which a work order is processed at a machine within the cell. He is only responsible for completing the work order package of his cell within time and other budget constraints. If there are cells that are sequentially interdependent within a stage, the local optima that will result from these decentralizations have to be managed such that the overall performance is according to plan. This is where stage co-ordination becomes important.

Three functions are seen as belonging to the task domain of stage co-ordination. These functions are described in the functional architecture in Figure 8.5:

- 1 determining intermediate release and due dates for work orders
- 2 enabling transfer of material (transfer batches) between cells
- 3 redirecting material, resource, and information flows between cells

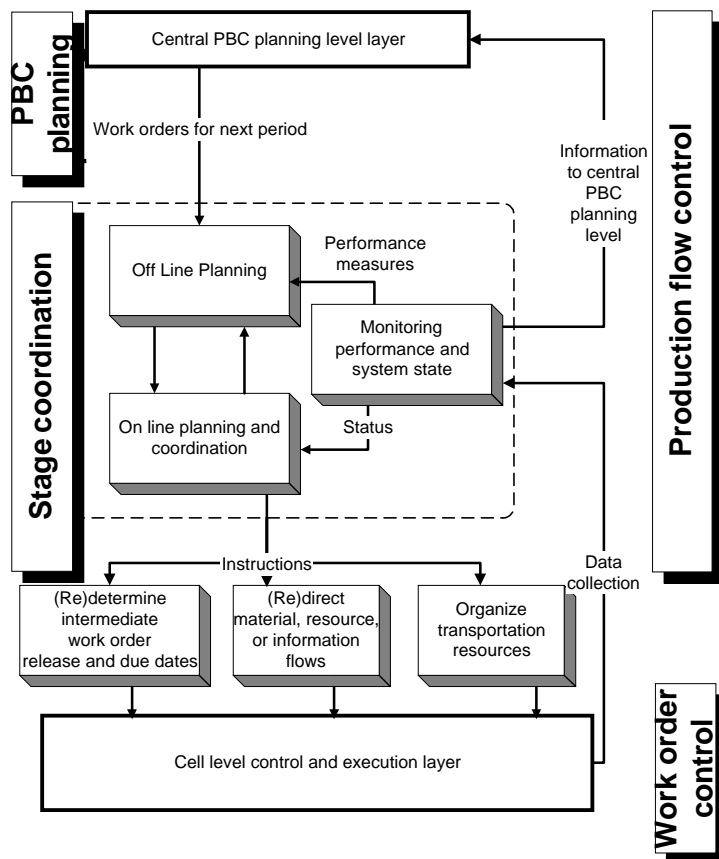

**Figure 8.5 Functional architecture of stage co-ordination level**

Within stage co-ordination, we can distinguish between off-line planning activities, on-line decision making and implementation, and monitoring both performance and system state.

The off-line planning task develops off-line plans for the current PBC planning period. This plan may be used to determine realistic intermediate release and due dates for the work orders released from the PBC planning level. The plan can further be used to extract information on the required transportation resources for between cell flows of transfer batches. It depends on the stage decomposition, on the length of the period, but also on the system objectives and the autonomy of the cells if such an off-line plan has to be made and how it is used. The IDD stage co-ordination policy that we used in our simulation study might have been not the most appropriate given the distribution of uncertainty within the system. The intermediate due dates that result from the stage co-ordination policy can be used to perform several necessary preparations, such as the arrangement of transportation equipment in order to deliver material to other parts in the system, without affecting the autonomy of cells.

The on-line tasks relate to all required co-ordination activities with cell controllers, the provision of instructions with respect to the organization of transportation resources, and the redirection of flows between cells. These tasks involve the communication of the expected release and due dates to cell controllers. Cells that propagate local solutions that make it

impossible for other cells to realise their goals can be amended at stage co-ordination level through a change in the release and due dates within the planning period. This influences the decisions at cell level. A relationship from on-line planning to off-line planning is needed. Finally, monitoring notifies the behaviour of the system and checks on circumstances that may require control efforts in order to enable the execution of the original plan.

### § 8.2.3 Examples of stage co-ordination

The case studies that we have performed show some examples of stage co-ordination, although they do not use a PBC system. However, they encounter relationships between cells and we have shown in Section § 2.3 that cases choose to co-ordinate some of these relationships without intermediate intervention of the central planning system. The sequential relationships between a prefabrication cell and a fabrication cell, between two fabrication cells, and between a fabrication cell and a finishing cell were sometimes co-ordinated by a type of stage co-ordination. We also identified that Case IV did not apply stage co-ordination for the sequential relationship between cells in the same stage, causing a low dependability.

Literature provides also some interesting examples of stage co-ordination. Dale and Russell (1983) report on a firm that introduced *shop loading analysts* in order to bridge the gap between overall production plans and cell supervisors, who have to meet the plans, whether possible or not. The company believed that if cell supervisors were given too high workloads and too short due dates, they would eventually return to 'functional' thinking with a totally unplanned transfer of labour and material between cells. The shop loading analysts were given the following tasks and responsibilities:

- 1 Translate the central plan for this period into realistic workloads for each of the cells.
  - Capacity related factors such as material, manpower, and machine availability, expected excess work (modification and rectification) had to be considered.
  - Intermediate release and due dates had to be determined for work orders that required assembly within the same period. They had to liaison with the monitoring function for co-ordination of the resulting *simultaneous relationships* between cells *within* the stage.
- 2 Negotiate with central production planning on desired modifications in the central plan (more/less work for underloaded or overloaded resources).
- 3 Make specific subcontract and group reallocation recommendations based on the expected loading for at least five planning periods ahead in time.
- 4 Analyse the variations from the central plan in the last planning period and identify relevant reasons for these variations and enable adequate monitoring.

Greene and Sadowski (1983, 1986) addressed the need for stage co-ordination in a cellular system. They describe a situation where the allocation of a work order to a cell had still to be performed at stage co-ordination level. The central planning level only determined that there would be sufficient capacity to perform the operation. The allocation of the work order to a cell was based on the loading patterns of the cells.

### § 8.2.4 Final remarks

We conclude from this analysis, that co-ordination between cells within a stage can be performed at a central stage co-ordination level if the achievement of system objectives necessitates improved planning and control compared with the co-ordination provided by a basic unicycle PBC system. The type of co-ordination mechanism that should be applied depends on the configuration of the PBC system. If stage decomposition within PBC resembles the cellular structure of the production system, less sequential co-ordination has to be performed at stage co-ordination level. The co-ordination of other relationships between cells may still be necessary. We distinguish three functions at stage co-ordination level: determining intermediate release and due dates for work orders, enabling transfer of subbatches between cells, and redirecting material, resource, and information flows between cells. We have provided a functional architecture for stage co-ordination that consists of an off-line planning for the current period, on-line planning and co-ordination activities for between-cell control, and finally, monitoring performance and system state.

## § 8.3 Conclusions

PBC system design choices affect the distribution of uncertainty in a cellular manufacturing system. A change in the length of period influences both the conversion uncertainty within the cell and boundary transaction uncertainty between cells. A change in the number of stages might result in a change in conversion uncertainty, but does not influence boundary transaction uncertainty, neither within nor between cells. Changes in the allocation of operations to the stages most importantly affect the distribution of uncertainty within and between the cells. If the allocation results in more cells becoming sequentially related within a stage, conversion uncertainty and boundary transaction uncertainty between the cells increase. If the allocation results in more operations of a cell being performed in successive stages, conversion uncertainty and boundary transaction uncertainty within the cell decrease.

In order to cope with the distribution of uncertainty that results from PBC design, appropriate co-ordination mechanisms should be used. We have argued that allocating regulatory decision authority to cells is not sufficient for all possible distributions of uncertainty. Especially in case of sequential relationships between cells, we need an intermediate co-ordination level between central PBC goods flow planning and decentral (local) cell planning. We introduced the notion of stage co-ordination and provided a functional architecture of this co-ordination level. Stage co-ordination should determine intermediate release and due dates for work orders, enable the transfer of material between cells, redirect material, resource, and information flows between cells when necessary, and monitor performance. We distinguish between off-line planning activities, on-line decision making and implementation, and monitoring. The necessity of stage co-ordination does not imply a specific distribution of authority within the system. It may be provided by a planner or by cell foremen.

---

## Chapter 9 Conclusions and further research

The purpose of this study is to gain insight into the main factors that should be taken into account when designing a planning system for the co-ordination between cells in a cellular manufacturing system. The conclusions of this study will be presented and summarized in Section § 9.1 and Section § 9.2 will provide some recommendations for further research.

### § 9.1 Conclusions

The historical development of planning system design cannot be explained solely in terms of theoretical progress or information technology advancements. Redesigns of the planning system have also been initiated as a result of the influence of several stakeholders, including customers, shareholders, and labour force, as also as a result of a change in position and power of the planning function in the organization. We would therefore also expect a change in the planning systems of firms that have chosen to apply cellular manufacturing in their small batch production. These changes might be instigated either to avoid any negative consequences of such a change in the production system, or to provide opportunities that were not as easily obtainable with the former production system design.

In cellular manufacturing systems, several operations per work order are performed within one unit, the cell. The main benefits of such a system are substantial reductions in throughput time, lower work in progress, improved quality and accountability, and workers who are trained to carry out various operations. It should be noted that these benefits are particularly obvious if the production system has been using a functional organization. If they used formerly a line organization, the main benefits of a change to cellular manufacturing will be a more robust system, improved volume and mix flexibility, higher job satisfaction, and improved quality.

Literature on cellular manufacturing and socio-technical systems design often assumes that the delegation of planning tasks and responsibility to cells automatically results in an easy to accomplish overall co-ordination of the goods flow in the system. We conclude that this is a far too simple view of the co-ordination issue within multi-stage cellular manufacturing systems. It might be true for a specific type of cellular manufacturing systems, i.e., single-stage cellular systems, in which completely autonomous cells produce a whole product for a separate segment of the market. In multi-stage cellular manufacturing systems, where our study focuses on, relationships between cells generally do arise in the process of transforming customer demands into finished products. We conclude that there are valid reasons for the existence of these relationships between cells in such multi-stage systems, and hence they should be co-ordinated adequately. The relationships between cells that require co-ordination should not be restricted to material flow relationships. In some situations, the co-ordination of specific resource and information flows may also be important.

Our study provides a typology of relationships between cells. We make a distinction between sequential, simultaneous, and latent relationships between cells. The determination of the type of relationship provides information on the extent of the co-ordination requirements between these cells. The framework of relationships between cells and the analysis of the five case studies have revealed that the co-ordination issue within multi-stage cellular manufacturing systems is an important aspect of planning system design. We found a huge variation in co-ordination mechanisms applied by firms in order to cope with these co-ordination requirements. The specific relationships between the cells explained for a large part this variety, in addition to the system objectives, the available resources, and the planning and information systems used. The effect of planning system design choices on the possibility of effectively co-ordinating the sequential material flow relationships between cells should be considered, as well as other sequential, simultaneous, and latent relationships between cells.

The second research question of this thesis concerns identifying the main factors that distinguish the basic unicycle period batch control system from other planning concepts in supporting the co-ordination requirements between cells. We conclude that the basic unicycle PBC system can be distinguished from other PBC systems and alternative planning concepts such as MRP and Kanban in the application of *three* principles: it is single cycle, both at programming and ordering level, single phase, and uses a single offset time. Furthermore, it uses a cycle time that is equal to the offset time and phase of the system. The combination of these principles results in a thorough cyclical planning system, which is able to provide central co-ordination of flows between cells in a multi-stage cellular manufacturing system.

The third research question addresses the design choices in this PBC system for appropriate co-ordination between cells and the effect of these choices on system performance. We conclude that the degree of control provided by central PBC co-ordination depends on three main factors: the period length  $P$ , the number of stages  $N$ , and the contents of these stages (the definition of the work orders). These three design choices in a basic unicycle PBC system are not always considered in comparative studies on planning system performance. This has resulted in these comparisons producing contradictory results. Hence, we need to improve our understanding of the main design choices of such systems and their effect on performance.

The design of the production system and the planning system are interrelated. This has consequences for the procedure for determining the parameters of PBC system design. We have shown that it can result in huge inefficiencies if the structure of the production system is designed independently of understanding about appropriate structures for planning systems. The decomposition of the production system into cells need not correspond with the decomposition of the planning system into stages. We developed a framework that identifies the various choices that should be made in order to determine an adequate division of the planning system into stages. This framework starts with formulating the desired mix of system objectives (speed, dependability, flexibility, quality, and costs). The central issue is to consider changes in either uncertainty or required accurateness of control between successive operations as indicating a need to introduce a stage decoupling point between these steps.

The length of the planning period  $P$  has important consequences for two operational issues relating to the PBC system. Both issues originate from the cyclical, periodical characteristics of the basic unicycle PBC system. We have called them the start/finish and set-up time effect.

The start/finish effect describes the utilization losses due to the unavailability of work at the start or finish of a period, because the work has to visit preceding or subsequent operations in the same period as well. The length of  $P$  influences the size of the batches and hence the start/finish effect. If  $P$  increases, it takes longer before a work order arrives from a preceding work station that has to be visited in the same period.

The set-up time effect describes the influence of set-ups on the net available capacity. It should be noted that the size of the set-up times does not depend on the size of the period length. However, the total number of set-ups in a year does depend on the length of period and hence a decrease in  $P$  reduces the net available capacity in the system.

Together, the size of  $P$  and the number of stages  $N$  determine the manufacturing throughput time  $T=N \cdot P$ , and hence the customer order lead time or the forecast horizon that has to be used in the planning system. The definition of the stages (both the number of stages and their contents) influences the performance of the system with respect to dependability. The use of overlapping production (transfer batches or subbatches) improves dependability. However, the introduction of overlapping production has important consequences for the operation of a cellular manufacturing system. The PBC design choices should therefore be made with care.

The mathematical models that we have developed show that the period length and a suitable batching policy both have an important effect on the costs of the system. This holds true both for production situations that allow only an equal number of subbatches per operation and for situations with a varying number of subbatches per operation. In the latter case, we show that co-ordination requirements between successive operations differ for nested, powered-nested, and non-nested batching policies. Hence, the specific variable batching policy used will affect the cost of co-ordination in the system.

In order to choose an appropriate value for the PBC system design parameters  $P$ ,  $N$ , and the subbatch policy that should be used, we developed two heuristic solution approaches. In these heuristics, the number of stages  $N$  is a function of the ratio between the expected maximum total throughput time and the period length  $P$ . We firstly developed an enumerative search heuristic. For a specific period length  $P$ , this heuristic determines a suitable subbatch strategy that minimizes total costs. It should be noted that a subbatch strategy influences the total throughput time and hence the required number of stages in the system. The heuristic compares the costs of the configurations at the various period lengths  $P$  and chooses the configuration with the least costs. The other solution approach is the progressive search heuristic. This heuristic searches for both a variable subbatch strategy and a period length that results in minimal costs. The progressive search heuristic outperformed in 92% of the experiments the time-consuming enumerative search heuristic.

The results of search heuristics cannot be directly used for configuring a basic unicycle PBC system. The assumptions behind the mathematical model are not completely in accordance with the characteristics of this system. This holds especially true for the periodicity (single-phase principle) of the system. Furthermore, the heuristics do not take into account the effect of stochastic variety on system performance. We therefore firstly considered the effect of the periodicity of a PBC system under various circumstances and policies by simulation analysis.

Literature on PBC system design generally assumes that system performance improves if either the number of stages decreases or the period length. Such a decrease results in a smaller manufacturing throughput time  $T$ , which raises the question as to what extent the change in the PBC design factors  $N$  and  $P$  in itself contributes to a change in system performance.

We have studied the effect of varying  $N$  and  $P$  while their product  $T$  remained constant. We conclude that the trade-off between systems with large  $N$  and small  $P$  and systems with small  $N$  and large  $P$  is essential, as it has important consequences for both the performance (amount of overtime work and costs) and the operation of the PBC system. Simulation experiments have shown that a configuration with small  $N$  and large  $P$  result in less set-up time losses, but in higher amounts of overtime work. Configurations with large  $N$  and small  $P$  result in improved co-ordination and control, higher bottleneck utilization, smaller order lead times, but also in higher set-up and material handling costs.

The simulation study was performed for two production situations that differ in the degree of routing variety within the cells. The first production situation showed that the number of stages and the number of transfer batches are the most important experimental factors. The scheduling policy within the cell and the type of stage co-ordination has a much smaller influence on system performance. The introduction of routing variety has no effect on this conclusion, but it does have a substantial effect on system performance. The effect of introducing mix variety is also present, but its impact is smaller. The conclusions remain valid under various levels of system utilization.

The analysis also revealed that the determination of the contents of the stages is an important factor in the design of the PBC system, even if the length of period  $P$  and the number of stages  $N$  are known.

The simulation model enabled us to test a configuration proposed by one of the search heuristics. Due to the differences in purpose and use of the simulation model and the mathematical model for determining a PBC configuration, we had to modify several elements of the heuristics in order to compare the results of the proposed configuration with already performed experiments. The procedure for proposing configurations had to be corrected for underestimation of the amount of overtime work needed. This is due to the characteristic flow-shop structure of the cellular manufacturing system that we tested. If the calculated throughput times were corrected with a small correction factor (95%), this resulted in configurations that are more realistic. These configurations resulted in a strong decrease in

costs (at least 15% cost reduction was achieved) compared with the originally tested configurations. This was mainly due to the smaller throughput time that resulted from the proposed configurations.

We conclude that a search heuristic can provide valuable information on a suitable initial configuration of a PBC system. However, the deficiencies of these heuristics with respect to the characteristics of the basic unicycle PBC system have to be taken into account. Therefore, the configuration that is proposed by a search heuristic should not be considered as a blueprint for PBC system design, but may be used as a first step in a design process that consists of four steps. An integral design for a manufacturing system that uses cells and co-ordinates its production with a PBC system needs to take into account the interaction between production system design and planning system design.

Finally, we have considered the effect of PBC system design choices on the co-ordination between and within cells. We conclude that these choices affect the distribution of uncertainty in a cellular manufacturing system. We make a distinction between conversion uncertainty and boundary transaction uncertainty, either within or between cells. A change in the length of  $P$  causes a redistribution of uncertainty amongst the conversion uncertainty and the boundary transaction uncertainty between cells. A change in the number of stages  $N$  only affects the amount of conversion uncertainty within cells. Finally, a change in the allocation of operations to the stages has a most important effect on the redistribution of uncertainty in the system. If the allocation results in more cells becoming sequentially related within a stage, this causes an increase in conversion uncertainty and boundary transaction uncertainty between the cells. If the allocation results in more cell operations being performed in successive stages, this leads to a reduction of conversion uncertainty and boundary transaction uncertainty within the cell.

PBC system design choices not only affect the occurrence of sequential and simultaneous relationships between cells within a period, but also affect the possibility of exploiting latent relationships. A larger period length makes it more difficult to exploit these relationships. Stage definition affects the possibility of using latent relationships between cells.

In order to cope with the resulting distribution of uncertainty in the system, appropriate co-ordination mechanisms have to be designed. The PBC system provides only for the central co-ordination between stages. We introduced the notion of stage co-ordination in order to fill the gap between central PBC co-ordination and decentral cell co-ordination. Three functions were seen as belonging to the domain of stage co-ordination: (1) determining intermediate release and due dates for work orders that pass through various cells within a stage, (2) enabling transfer of material between cells, and (3) redirecting various types of flows between the cells. We further distinguish between off-line planning activities, on-line decision making, and monitoring. Finally, we conclude that the allocation of the tasks of stage co-ordination in the planning system to either cell co-ordinators or central planners depends on the characteristics and objectives of the manufacturing system.

The conclusions of our study with respect to the design choices in a basic unicycle period batch control system have implications for the design of other planning systems as well. Most MRP systems use time buckets, but the length of a time bucket is not often discussed in MRP literature. On the contrary, much attention has been paid in the last decade to the reduction of the number of levels in the Bill of Materials. This number of levels corresponds with the number of stages in a PBC system. Our study has revealed that for a basic unicycle PBC system, it is better to increase the number of stages and at the same time decrease the period length. This result is at odds with the path followed in redesigning MRP systems. However, it should be noted that we have not studied the effect of introducing multi-offset times, multi-cycles at programming level, and different lot-sizing rules on the performance of a PBC system. This may influence the implications of our conclusions for the design of related planning systems.

Our study has shown that a change towards cellular manufacturing has important consequences for planning system design. The design of a planning system has to resemble the inherent characteristics of the production system and vice versa. Nevertheless, the decomposition of the production system into cells need not correspond with the decomposition of the planning system into stages. Stage allocation should reflect the intrinsic uncertainty and required accurateness of control between successive operations. The cellular structure influences this decision about stage definition.

## § 9.2 Recommendations for further research

Our study identifies the mutual relationship between production system design and planning system design as an important element in manufacturing system design. Product and process design provides input for decisions with respect to planning system structure and decomposition of the production system. This raises questions about the quality and specifics of the decisions in the product and process design phase. The relationship between process planning and production planning should be reconsidered from the perspective of the ability to improve the design of both production and planning systems

Literature on cellular manufacturing system design provides many methods for production system decomposition. Most methods decompose a part/machine matrix into a block diagonal form. This approach is only applicable for single-stage cellular manufacturing systems. Decisions about appropriate segmentation of the production system have to be taken in advance. The methods that we have developed for planning system decomposition might also be useful for improving the production system decomposition algorithms. As the block diagonal form will not be suitable for these algorithms, this will also require further study towards appropriate measures of performance for cellular decompositions.

The results of this study were obtained from a rather rigid planning system. This has enabled us to focus on a number of elementary design choices that also appear in other planning systems with more degrees of freedom. For example, in MRP systems, we have to determine the size of the time bucket (period length), replanning frequency, work orders, and planned lead times as well. Megens (1999) confirms our experience in respect of the parameterisation of such systems.

Academic researchers have published a lot on more ‘advanced’ planning features, such as discrete lot sizing and the relationship to capacity analysis. Implementation consultants have primarily directed their attention to the speed and dependability aspects of the implementation process instead of the quality of the implementation. This may be no real problem in functional organized production systems, as in these cases the structuring of the BOM is quite evident and the estimation of the planned lead time of a work order is considered to be a consequence of the former decision.

However, cellular manufacturing systems are more sensitive to these planning system design choices, because of the loss of pooling synergy (Meredith & Suresh, 1994). If the parameterisation of the planning systems they use is not carefully undertaken, this may put achieving the desired benefits of cellular systems under threat. We should therefore pay explicit attention to the quality of planning system design choices in respect of cellular manufacturing systems. Further research should focus on providing implementation consultants with instruments to improve the quality of these decisions on planning system design. This will require modification of the reference models that they use in the

parameterisation of the system. It also will require the development of simulation tools that they can use in making trade-offs between the various design choices. The tools provided by this study have to be further developed in order to make them suitable for application in realistic settings.

Our study has revealed that in basic unicycle PBC systems, the dependability of the system improves if one reduces the length of the time bucket and increases the number of levels in the BOM. Studies on MRP system design can benefit from the insights that this study provides on the length of the time bucket and structure of the Bill Of Materials. However, MRP systems are generally multi-cycle and multi offset time, and nowadays many are also multi-phased. Further research should therefore reveal the validity of these results for multi-cycle, multi offset time, and multi-phase systems. Our simulation model can easily be modified to perform such an analysis.

The system that has been described by Steele, Berry and Chapman (1995) uses such a multi-phase loading. They consider the effect of various positions of a weak cell, and conclude that the impact of a weak cell at the final stage has most impact on the dependability. We expect that these conclusions will not remain valid for single-phase systems as well. Our simulation model can be used to test these conclusions for single-phase loading.

We have experimented with two types of multi-stage cellular manufacturing systems, either with or without routing variety in the cells. Our results indicate that design choices for basic unicycle PBC systems in both cases significantly affect system performance. Further research should reveal if these results also hold true for other multi-stage cellular production situations.

The mathematical model for determining a suitable configuration of the PBC system (Chapter Five) can be combined with the mathematical model for determining a suitable stage allocation (see Appendix B). Combining both models enables the determination of a PBC configuration that reflects the single-phase principle, which improves the design of the PBC system. A new heuristic solution approach has to be developed for such an extended model.

Further research should make it possible to improve the accuracy of finding a suitable value for the lowerbound correction factor in both the mathematical model and solution approaches presented in Chapter Five. Estimation of the total throughput time in the system has important consequences for the dependability and costs of the system. These make it worthwhile to consider such improvements.

In addition, future research should address the problem of allocating tasks, responsibility and authority within the planning system. Our study has addressed the need for an intermediate level of stage co-ordination between central PBC co-ordination and decentral cell co-ordination. However, this distinction in levels does not imply that the planning tasks at these levels should be performed by different persons within different organizational units. The factors that have to be considered in designing these aspects of the planning system

---

should be identified in future research. If this results in extended rules for stage co-ordination, our simulation model can be used to determine the effect on system performance.

In this study, the problem of planning system design has been considered mainly from a theoretical point of view. Future research should attempt to test the proposed design approach in practice. We expect that such an attempt will reveal additional insights into the factors that should be taken into account in designing a planning system for cellular manufacturing systems. From our contacts with firms that apply variants of PBC systems, we know that the technical parameter choices (period length, number of transfer batches, work order definition, and number of stages) do not remain constant for a long time. The determination of these parameters affects the possibilities there are for the system to improve its performance. This effect should be taken into consideration in successive studies on the design of planning systems for cellular manufacturing.



---

## Appendix A. Short case descriptions

This appendix introduces the five cases that we have studied. The cases are independently introduced, to give the reader the possibility of getting an impression of the firms and of the variety present in these cases. In the appendix, we describe the characteristics of the cases. In the main text of Chapter Two, we pay attention to the types of relationships between cells and the corresponding co-ordination requirements. The objective of the case studies is to identify the variety of planning problems of firms that apply cellular manufacturing in their small batch mechanical part production.

The description of the cases is organized as follows. After a short introduction of the company, we characterize the situation in terms of the type of products, demand characteristics, requirements of the market, size of the assortment, number of employees and number of shifts.

Next, the cellular organization is described, accompanied with a scheme of the goods flow. In these schemes, cells are located at a specific processing stage. We distinguish between cells (represented as *boxes*), departments of similar cells (*dotted rectangle*), and service departments that are shared by the cells (*dotted ellipses*). External service departments or subcontractors are positioned outside the boundaries of the production system. *Arrows* represent the flow of goods in the system. *Triangles* represent stock positions, and *dotted triangles* mark that these positions are not in constant use.

We further pay attention to the degree of automation, type of layout, criterion used in the formation of the cells, presence of a remaining cell, and the sequence of visiting the cells if a main goods flow in the system exists.

Finally, characteristics of the available resources are described. We pay attention to the storage and registration of tools and the corresponding investment policy. Furthermore, we address the operator flexibility and other instruments, such as overtime and subcontracting, which are used to obtain the required flexibility in the production system.

At the end of this appendix, we summarize several relevant aspects of the cases we studied. We focus on the number and type of cells in these firms.

The information on these cases is gathered from interviews during short visits and meetings with employees of these firms in 1994 and 1995, and from reports of student research projects that we supervised in these firms. In the description of the cases, the anonymity of the firms is respected as much as possible.

## A.I. Case I Complex machines

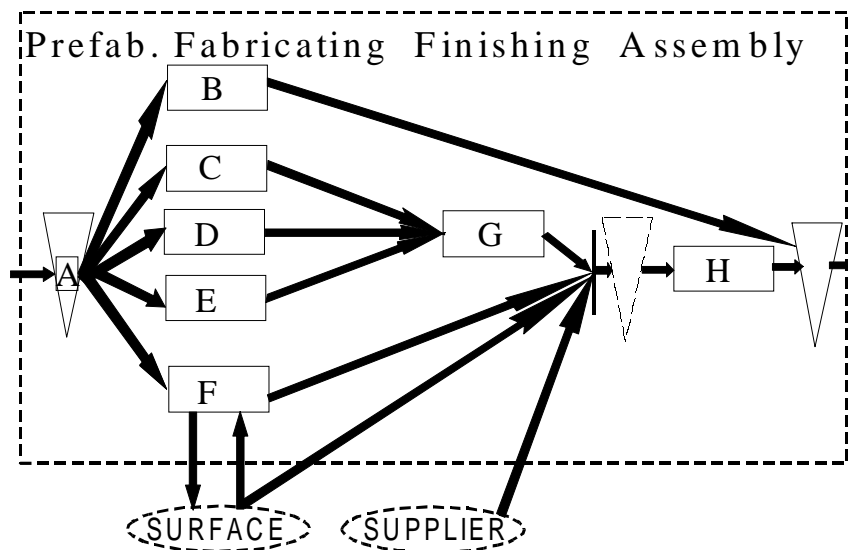

**Figure A.1 Goods flow case 1 Complex machines**

Case I is producing complex machines that are an important element of the capital intensive production process of their industrial customers, 95% of them being situated in the Far East. The machines are being made to order, with some engineering activities for specific requirements of a customer. The lead time of a machine is half a year. In the production site that we have studied, work 550 people in a two shift production.

The processing stages that were present are material processing, mechanical parts production, finishing and assembly. The required sheet metal is produced in another production site and either delivered to the assembly stock or to a parts producing cell. Half of the 100,000 parts and components are being bought externally. Complementary to the new machines, spare parts are demanded. These parts are responsible for 10% of the machine hours.

The production system consists of a prefabrication cell A, a remaining cell B, four parts production cells C-F, a finishing cell G, and an assembly cell H, as can be seen in Figure A.1. Two of the parts producing cells only perform machining operations (C and E); the other two can also perform operations on sheet metal (D) or simple assembly operations (F). The degree of automation varies between the cells. C is highly automated, D and F use various NC machines, and E is hardly automated.

The cells were designed by using the criterion 'shape and volume of the products', which explains the various degrees of automation. The change to cellular manufacturing was initiated by the introduction of an FMS system.

The remaining cell B has specialized on the fabrication of tools. This cell is not involved in the main production activities due to the high costs of the people who work in this cell.

Tools that are exclusively used in one cell are stored decentrally. They can be placed in a separate toolmagazine, but cutting tools can also be placed in an integrated toolmagazine within the machine. Tool types that are used by more cells are being duplicated as much as economically can be justified, so no resource conflicts will arise. Still a considerable number of tools exist (especially fixtures) that are centrally stored and released on request. The resulting flows are not controlled.

Due to the presence of similar operations in the various cells, some operator flexibility is available between the parts producing cells. Allocation of work orders is done independent of the current work load balance between the cells. If a cell is overloaded, it can self decide about the interchange of work with either another cell or an external subcontractor.

A considerable percentage of the parts have to undergo one or more finishing operations. Special surface operations are subcontracted, taking 2 weeks throughput time, but cleaning and painting are done in the finishing cell G. Three colors are used for painting, one of them irregular. The inventory before assembly is a decoupling stock; it functions as a time buffer.

## A.II. Case II Complete installations

Case II is producing complete installations, consisting of a number of highly automated complex machines that are placed in line. Due to the modular design of the installations, a high degree of standardization within the production is achieved, especially in the fabrication of the machines, which is done in the production site we visited. The installations are being made to order with some engineering activities for specific requirements of a customer. The firm produces  $\pm 35$  installations a year, cumulating to a demand of 750 machines a year, demand of spare and wear parts being complementary. Of the 35,000 part types used in these machines, 15,000 are produced internally. Production is done in two shifts and some 400 people work in this organization.

The requirements on quality, reliability and lead time performance are very strict, as the installations are a vital element of a continuous production process. The replacement of the old installation with the new one is planned a few months in advance and has to take place within a very short time. These requirements have led to the introduction of cellular manufacturing.

The cellular organization in this site consists of a prefabrication cell A, five parts production cells C-G, one remaining cell B, one finishing cell H and three assembly cells I-K (Figure A.2). The required elements for the conveyor chain are produced in another production site and delivered to the assembly stock.

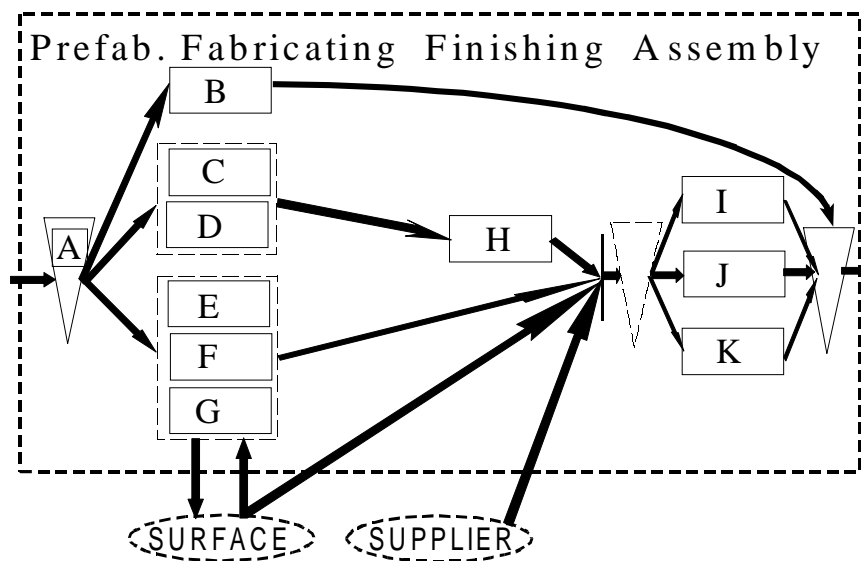

**Figure A.2 Goods flow case II Complete installations**

The parts production can be divided in a cluster of three cells E-G where the mechanical parts are being produced, and a cluster of two cells C-D for sheet metal operations. The latter is related to the finishing cell. The degree of automation in the mechanical parts production cluster is very high, as the simple work is structurally subcontracted. One of the sheet metal cells (D) also performs some simple machining operations on the material.

The remaining cell B has specialized on the fabrication of tools and prototypes. This cell is only involved in the main production process if high precision repair work or rush work has to be done. External subcontractors are often cheaper, so their involvement is generally preferred.

The parts production cells are designed by using the criterion 'shape of the products' and orders are allocated to the cells based on the required main processing operation. Assembly cells are not specialized in specific products. The inventory before assembly is a decoupling stock with a time buffer of minimal three working days.

The tools that are needed in parts production are stored decentrally. A tendency exists towards designing more cell-specific tools in stead of product-specific tools. Capacity in the assembly cells is partly determined by the availability of product carriers.

Operator flexibility within the clusters of machining cells E-G and sheet metal cells C-D is much higher than between these clusters. Cells can also choose to work in overtime making use of a machine in another cell. The cell foreman is allowed to take subcontracting decisions on his own. He stays responsible for the subcontracted work, for the delivery of the material, tools, NC programs, and documents, and for the lead time performance.

## A.III. Case III Complex installation

Case III produces complex installations that consist of two main modules, Y and Z. A considerable part of the demand is on module Y only, which is delivered in four basic types, each in ten variants obtainable. Module Y is assembled to order. 80% of the orders for module Z require some engineering activities before production can start. The throughput time of an installation is eight weeks, due to the late start of the production of Z if engineering activities are necessary. There are 300 employees; half of them are directly involved in the production.

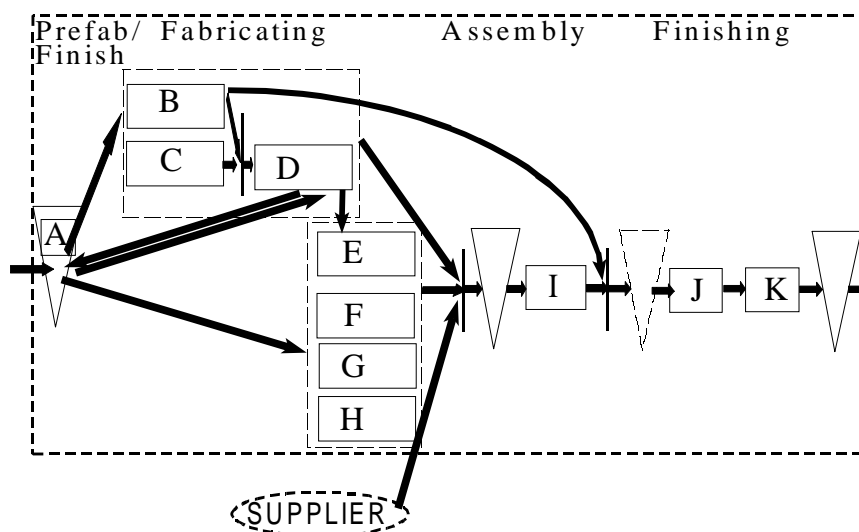

**Figure A.3 Goods flow case III Complex installation**

Production takes place in cells (see Figure A.3). The cellular organization consists of one pre/post processing cell (A), three welding cells (B-D), a cluster of four machining cells (E-H), one of them being a remaining cell (H), two assembly cell (I, J) and a finishing cell (K). Before the assembly cells a planned stock is found.

The prefabrication cell delivers the required material to the parts production cells. Cell B produces module Z and delivers it to assembly cell J. In the production of module Y first the welding cluster is involved, next the machining cluster, and afterwards the main part is put in stock. In the welding cluster first cell B is visited. Cell D uses the parts produced in the highly automated cell C and welds them on the part delivered by cell B. Cell D uses a line layout for this welding operation. Next, for the required postprocessing operation cell A is (again) visited. The quality check is again performed in cell D.

The next step in the production of module Y is machining in the highly automated cell E. This cell produces in two manned and one unmanned shifts. The other three cells in the machining cluster produce parts for the assembly of module Y. One of them (H) is a remaining cell that produces tools, performs maintenance, and can be involved for rush work. Cell F and G are dedicated to specific part families; G is even using a line layout.

Cell I performs the assembly of module Y. Cell J is involved if a complete installation is ordered and cell K performs the painting of the modules and installation. Tools that are used by more cells are duplicated and decentrally stored. Transportation equipment for intracell transport is a shared resource.

Much of the required flexibility is found in capacity inventory and in operator flexibility. A human resource pool is available in both clusters, although the pool is larger in the welding cluster. Reallocation of members of this pool is considered on request of a cell. In the machining cells, some simple work can be interchanged. Subcontracting is not preferred, although sometimes inevitable.

#### A.IV. Case IV Parts production make/engineer to order

Case IV produces parts. It is directly connected with its two main customers that belong to the same parent organization and are responsible for 90% of the orders, both new and repetitive. 10% of the orders require engineering activities. A direct linkage with the CAD systems of the main customers supports a quick delivery of the parts requested. The lead time of the orders ranges from one to four weeks. The organization employs 300 people, of which 190 are involved in the fabrication of parts, which is done in two shifts. Some 6000 different part types are produced each year.

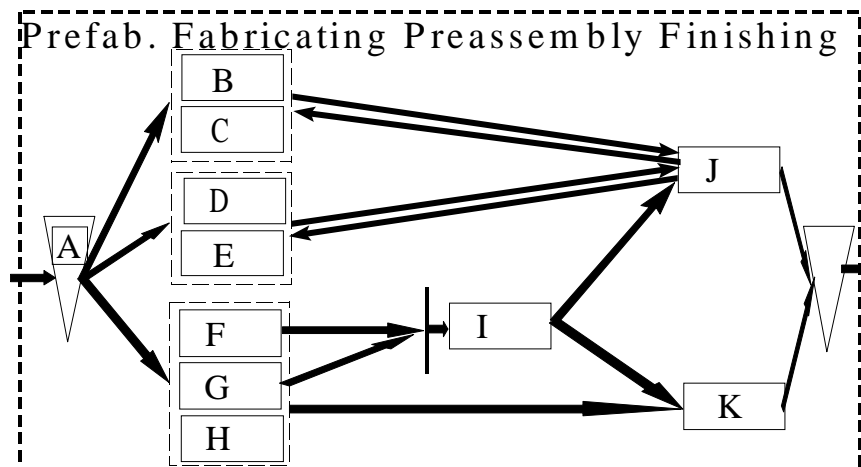

**Figure A.4 Goods flow case IV Parts production make/engineer to order**

Production is done in eleven cells (see Figure A.4): one pre-processing cell (A), two machining cells (B, C), three sheet metal cells (D-F), two punching cells (G, H), a pre-assembly cell (I) and finally two finishing cells (J, K). There is no remaining cell, as the fabrication of tools for both the main customers and themselves is performed in a separate part of the organization. The formation of the cells is based on the criterion 'shape of the product' and each cell is equipped with both numerically controlled and conventional

machines. One of the sheet metal cells is highly automated and can produce during an unmanned shift.

At the time the cellular organization had been adopted in this firm (1987), it consisted of eighteen cells divided over the three clusters. Cells within a cluster were more alike with respect to the type of machines allocated to these cells, and this would make the interchange of work and operators easily. Since then, the number of cells has been reduced due to diminishing turnover and problems with making use of the available flexibility between the cells.

Tools are central stored, even when the tools are product specific and used in one cell only. Central storage provides more space on the work floor and is preferred. Some of the tools that are used in more cells are duplicated, but this is regarded as a too expensive solution. Information on the availability and location of the tools is not registered.

The operator flexibility within the clusters is high, but not often used. Subcontracting for capacity reasons is possible, but not preferred. A small number of part types are sometimes used for producing capacity inventory, but the involved risk is often too big. Use of overtime can be decided on by the cell. If a cell delivers work to another cell, it stays responsible for the quality and delivery performance.

#### A.V. Case V Parts production make to order

Case V produces mechanical parts for all business units of its parent organization. It produces 6000 orders a year and has an assortment of 20,000 parts that can be made to order. The lead time ranges from five to seven weeks. Production is done in two shifts and 100 people are working in this organization.

The cellular organization (see Figure A.5) consists of a pre-processing cell (A), four machining cells (B-E), E being a remaining cell, a sheet metal cell (F), and a finishing cell (G). Machining cell B is a highly automated cell with a flow line layout. Furthermore, two separate departments (H, I) are shared by the cells. In department H, the operator performs surface operations, based on a quick service concept. To department I no operators are allocated. The numerically controlled machines in this department can be used by any cell. Each cell has operators that can handle these machines. The remaining cell E is involved in the production of prototypes and tools and is not often used for rush work or interchange of operators.

The two machining cells C and D produce parts for different product/market combinations, i.e. for different business units. The types of machines that are allocated to these cells are alike, but as far as the numerically controlled machines concerns not interchangeable, due to

the different programming languages. The machinery consists of 125 conventional machines and almost 40 CNC machines.

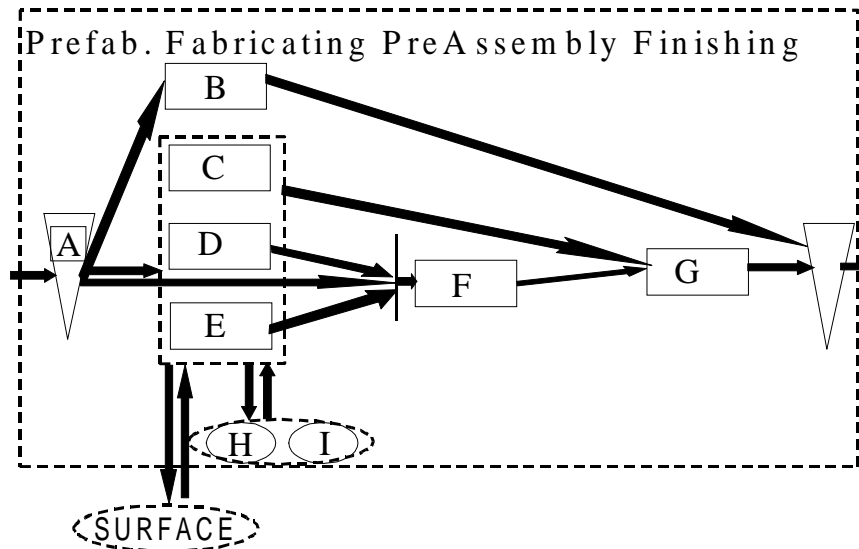

**Figure A.5 Goods flow case V Parts production make to order**

As much as 20% of the orders require operations outside the cell. In this percentage, the operations performed in departments H and I are not included. Most of these operations are externally performed surface operations. An example of internally performed operations concerns orders, allocated to the sheet metal cell, that require welding of parts. These parts first have to be made in other cells, causing operations to be performed outside the cell.

The firm has the disposal of 6,000 different standard tools and 20,000 types of special tools. Tools are central stored. Duplication of tools is often too expensive. Location and usage of tools is not registered. Some 5% of the orders are delayed because the required tools are not available at the time production has to use it.

Operator flexibility is not of main interest to this firm. The required system flexibility is found in changing the allocation of simple work between the machining cells, in delaying some work, or in using overtime, subcontracting or temporary workers in the finishing department.

## A. SUMMARY OF CASE DESCRIPTIONS

The case descriptions show a variety of cellular configurations, a different degree of automation between cells, and various contributions of a remaining cell in generating flexibility in the primary process. Table A.1 summarizes the main characteristics of these five cases in terms of number and type of cells.

Cases	I	II	III	IV	V
end product	complex machines	complete installations	complex installations	parts	parts
production situation	make/engineer to order	make to order	assemble to order	make/engineer to order	make to order
assortment	50000 parts	35000 parts	?	6000 parts/year	20000 parts 6000 parts/year
Type of Cell	Number of Cells				
<i>prefabrication</i>	1	1	1	1	1
<i>mechanical</i>	2	3	3	5	3
<i>plate/welding</i>	0	1	3	5	1
<i>combined plate/mechanical</i>	2	1	0	0	0
<i>finishing</i>	1	1	1	2	1
<i>assembly</i>	1	3	2	1	0
<i>remaining cell</i>	tool fabrication	tool fabrication	tools + specials	NA	tools+prototypes

**Table A.1 Characteristics of cellular manufacturing systems in case studies**



## Appendix B. Mixed Integer Programming for Stage Allocation

In order to facilitate the allocation of operations to stages, we have developed a mixed integer programming model that explicates the factors that should be taken into account when determining the contents of the stages. These factors have been discussed in Section § 4.4.

### Define

- $N$  = Number of stages  
 $T$  = Manufacturing throughput time  
 $P$  = Period length  $P \equiv T/N$   
 $j$  = Index of stage ( $j = 1..N$ )  
 $h$  = Index of product ( $h = 1..H$ )  
 $i_h, l_h$  = Index of operation ( $i_h, l_h = 1..n_h$ )  
 $\bar{d}_h$  = Mean demand for product  $h$  in next  $N$  sales periods of length  $P$   
 $O$  = Set of operations to be performed during  $T$   
 $F_i$  = Set of immediate followers of an operation  $i$   
 $s(i)$  = Setup time for operation  $i$   
 $p(i)$  = Processing time for one unit of operation  $i$   
 $MI$  = Machine Interference delay as percentage of period length  $P$   
 $Ta_j$  = Tardiness in stage  $j$   
 $I_{i_h l_h}$  = 1 if operations  $i_h \in O$  and  $l_h \in F_{i_h}$  are performed in different cells  
 $CD$  = Cell delay (incurred if  $I_{i_h l_h} = 1$  and both operations are allocated to the same stage)  
 $V_{i_h}$  = Value added after one unit of operation  $i_h$  has been made (including value of purchased parts)  
 $C_T$  = Inventory cost as percentage of value of one stocked item during  $T$  time units  
 $M$  = Big number ( $M \gg P$ )

### Decision variables

- $x_{i_h j}$  = 1  $\Leftrightarrow$  operation  $i_h$  allocated to stage  $j$ ; otherwise  $x_{i_h j} = 0$   
 $t_{i_h j}$  = earliest start time of operation  $i_h$  in stage  $j$

Having introduced the nomenclature we use, we present the *longest-path orientation* of the model in Section B.I and discuss the model. In Section B.II we extend the model with a *bottleneck orientation* that may be useful in designing a PBC system. Finally, Section B.III presents the results of the model for the data of production situation I of Chapter Six.

### B.I. Longest-path orientation in mixed integer programming model

The mixed integer programming model allocates operations to stages such that the investment in working capital is minimized (objective function (1)).

#### Model

$$\begin{aligned}
 (1) \quad & \min \sum_{j=1}^N \sum_{h=1}^H \sum_{i_h=1}^{n_h} (N+1-j) \cdot \frac{C_T}{N} \cdot V_{i_h} \cdot \bar{d}_h \cdot x_{i_h j} + M \cdot Ta_j && \text{such that} \\
 (2) \quad & \sum_{j=1}^N x_{i_h j} = 1 && \forall i_h \in O, h = 1..H \\
 (3) \quad & \sum_{r=1}^{j-1} (x_{i_h r} - x_{l_h r}) \geq 0 && \forall i_h \in O, l_h \in F_{i_h}, h = 1..H, j = 1..N-1 \\
 (4) \quad & t_{l_h j} + M \cdot \sum_{r=j+1}^N x_{l_h r} \geq t_{i_h j} + s(i_h) + \bar{d}_h \cdot p(i_h) + I_{i_h l_h} \cdot CD - M \cdot \sum_{r=1}^{j-1} x_{i_h r} && \forall i_h \in O, l_h \in F_{i_h}, h = 1..H, j = 1..N \\
 (5) \quad & t_{i_h j} + s(i_h) + \bar{d}_h \cdot p(i_h) \leq (1 - MI) \cdot P + Ta_j && \forall i_h = 1..n_h, h = 1..H, j = 1..N \\
 (6) \quad & x_{i_h j} \in \{0,1\}, t_{i_h j} \geq 0, Ta_j \geq 0 && \forall i_h = 1..n_h, h = 1..H, j = 1..N
 \end{aligned}$$

An operation  $i_h$  that is allocated to stage 1 will add  $C_T \cdot V_{i_h} \cdot \bar{d}_h$  to the total holding cost.

If this operation had been allocated to stage N, the added cost would have been  $\frac{(C_T \cdot V_{i_h} \cdot \bar{d}_h)}{N}$

However, the allocation of operations to stages is restricted for several reasons.

First, we define the *occurrence-constraint*. An operation has to be allocated to at least one stage in order to let the production system perform the operation. Constraint (2) together with condition (6) that  $x_{ij}$  is a binary variable ensures that the operation has to be allocated to one and only one stage. The uniqueness of stage allocation is a consequence of PBC.

Precedence relationships between operations make that if an operation  $i$  is allocated to stage  $j$ , then none of its followers  $l$  may be allocated to an earlier stage. Constraint (3) ensures this *precedence-feasibility* of the solution.

The reason why not all operations can be allocated to the final stage N is that the allocation has to be *time-feasible* as well. If too many sequentially dependent operations are allocated to the same stage, this may cause tardiness to occur. Constraints 4-5 determine the tardiness in a stage due to the sequential relationships between operations in the same stage, and the objective function minimizes the tardiness. The non-negative variable  $t_{i_h j}$  describes the earliest starting time of an operation  $i_h$  in stage  $j$ .

Constraint 4 sets the earliest starting time of an operation  $l$  with a predecessor  $i$  in the same stage to be not smaller than the earliest starting time of this operation  $i$  plus the total amount of set-up time and processing time required for the whole batch of  $i$ . If both operations are not performed in the same cell, then the earliest starting time of the latter operation  $l$  is further delayed with  $CD$ , a cell delay (policy) factor, which represents the organizational impact of such an allocation. If  $i$  and  $l$  are not allocated to the same stage  $j$ , then the use of the big  $M$  factor causes the constraints 4 to become non-binding.

Constraint 5 ensures that the earliest finishing time of any operation in stage  $j$  will not exceed a specified percentage of the period length  $P$ . This percentage depends on  $MI$ , the machine interference delay, which is expected to correct for delays that may occur in processing a sequence of operations due to the waiting times on availability of machines. If more time is needed in a stage, then the tardiness is assumed to become positive, which increases costs. The objective function tries to minimize costs and hence a solution without tardiness will be preferred. In this way, we are able to model the time/cost trade-off.

Note that the formulas of Chapter Five, Section § 5.1 can also be used to formulate Constraint 4 and recognize the influence of extra transfer batches and duplicate machines. This makes the model far more complex to interpret, and due to some non-linearity's also more complex to solve with standard software. However, the constraints can easily be modified to cope with these factors. This is important, as the solution that is found with our model may not be the most cost-efficient allocation of operations to stages, as we neglect the possibility of shortening the time delays between successive operations.

The actual occurrence of tardiness in a stage depends on the number of products that have to be produced. The sensitivity of an increase of this amount compared with the expected amount  $d_h$  may be quite high and depends on the sum of the processing times per unit on such a path in the stage. Instead of the expected demand we could also use the maximum allowable number of units of product  $h$  per period of length  $P$ . This will restrict the occurrence of tardiness problems (time), but will increase the investment (costs).

## B.II. Bottleneck orientation in mixed integer programming model

The former section has described a mathematical model that pays attention to the *longest-path orientation*. It has not considered machine capacity as a dominant factor in allocating operations to stages. The allocation of operations to stages does not influence the amount of work per machine, but it does influence the timing of the earliest arrival at and latest departure from a machine (the start/finish effect). We can add a *bottleneck-orientation* to the model in order to cope with this effect.

A *bottleneck-orientation* has to be applied if the utilization of a bottleneck resource is a dominant design principle in PBC system design. A bottleneck-orientation pays attention to the loading of resources during a period. Our bottleneck-orientation to stage allocation consists of the inclusion of constraints that try to determine if the bottleneck will exceed its capacity limits. The extra constraints and variables for the mixed integer model are presented below. Note that bottleneck problems can be solved with specific methods from single machine scheduling with release dates and due dates. Carlier (1982) developed an algorithm that finds a solution to such problems in  $O(n \log n)$  time ( $n$  is the number of operations to be scheduled at the machine). The inclusion of these constraints in our mixed integer model serves the purpose of presenting a suitable mathematical formulation of the stage allocation problem. Practical implementations of the model should better use a tailor made algorithm that allows solving much bigger allocation problems within reasonable time.

Constraint 7 ensures that the time delays in stage  $j$  are zero if the operation is not performed within stage  $j$ . Constraint 8 determines the remaining time in stage  $j$  after finishing operation  $i_h$  at the bottleneck. If the operations  $i_h$  and  $l_h \in Fi_h$  are performed in different stages, the remaining time is zero, but if they are performed in the same stage, then we have a positive remaining time. This restricts the scheduling capabilities on the bottleneck. Constraints 9-11 pay attention to this problem. For any subset of operations that have to be performed at the bottleneck we determine the earliest release time, add the total set-up time and processing time of this subset at the bottleneck, and finally add the minimal remaining time in this period (at other machines) after finishing this subset at the bottleneck. This sum may never exceed the period length  $P$ . All variables are non-negative (12).

#### Define

- $B_k$  = Set of operations  $i_h$  that have to be processed at bottleneck machine  $k$   
 $K$  = Subset of operations:  $K \subseteq B_k$   
 $f_{i_h,j}$  = minimal remaining time in stage  $j$  after finishing operation  $i_h$   
 $MinHead_k$  = minimal waiting time before bottleneck can start with subset  $K$  of operations  
 $MinTail_k$  = minimal remaining time after finishing subset  $K$  of operations at bottleneck

#### Additional constraints for Model

- (7)  $f_{i_h,j} \leq M \cdot x_{i_h,j} \quad \forall i_h \in B_k, j = 1..N$
- (8)  $f_{i_h,j} + M \cdot \sum_{r=1}^{j-1} x_{i_h,r} \geq f_{i_h,j} + s(l_h) + \overline{d}_h \cdot p(l_h) + I_{i_h,l_h} \cdot CD - M \cdot \sum_{r=j+1}^N x_{l_h,r} \quad \forall i_h \in B_k, l_h \in Fi_h, j = 1..N$
- (9)  $MinHead_k \geq t_{i_h,j} \quad \forall i_h \in K, j = 1..N$
- (10)  $MinTail_k \geq f_{i_h,j} \quad \forall i_h \in K, j = 1..N$
- (11)  $MinHead_k + \sum_{i_h \in K} \{s(i_h) + \overline{d}_h \cdot p(i_h)\} + MinTail_k \leq P$
- (12)  $MinHead_k \geq 0, MinTail_k \geq 0, f_{i_h,j} \geq 0 \quad \forall i_h \in B_k, j = 1..N, K \subseteq B_k$

The number of constraints increases rapidly as the cardinality of  $B_k$  increases. However, we need not check every subset  $K \subseteq B_k$ . We may restrict our attention to subsets of operations that may cause *MinHead* and/or *MinTail* to be non-zero, as this might result in infeasibility with respect to bottleneck capacity. This reduces the number of subsets to be considered.

Due to the specific structure of the sparse matrix of the extended mixed integer model (a large part of it has a structure similar to an uni-modular matrix) an optimal solution is easily found. We have used the Super Lingo software from Lindo Systems Inc. (LINGO manual, 1989) to test the extended model. The limits of this version are a maximum of 1000 variables and 500 constraints. On a Pentium II 266 personal computer, it took less than 2 seconds CPU time to solve problems with approximately this number of variables and constraints.

Note that if products have an identical product structure, but different set-up or processing times, a simplified allocation can be performed with this model by applying the same allocation of operations to stages for all these similar products.

Allocation of operations to stages is an important phase in designing the PBC system. It influences a number of system objectives, such as quality, costs and dependability. The mixed integer model explicates the decisions on stage allocation with respect to the time/cost trade-off. The basic model uses a *longest-path orientation* in the allocation of operations to stages. The model can easily be extended to facilitate a *bottleneck orientation*.

### B.III. Application of mixed integer model on production situation I

In Chapter Six, we perform a simulation analysis using data from the work of Steele, Berry, and Chapman (1995). The stage allocation that we apply is also deduced from their work, and is shown in Figure 6.11 in Section § 6.2.3. We have not used the stage allocation procedure described in this appendix for the allocation of operations to stages in the simulated production situation. At the time of performing these experiments, the limitations of the available LINGO software version were such that we could not obtain a solution for all stages.

We have solved a simplification of the mixed integer model with bottleneck machine 13. The simplification is that all products apply the same allocation of operations to the stages. The optimal stage allocation of this simplified model is presented in Figure B.1.

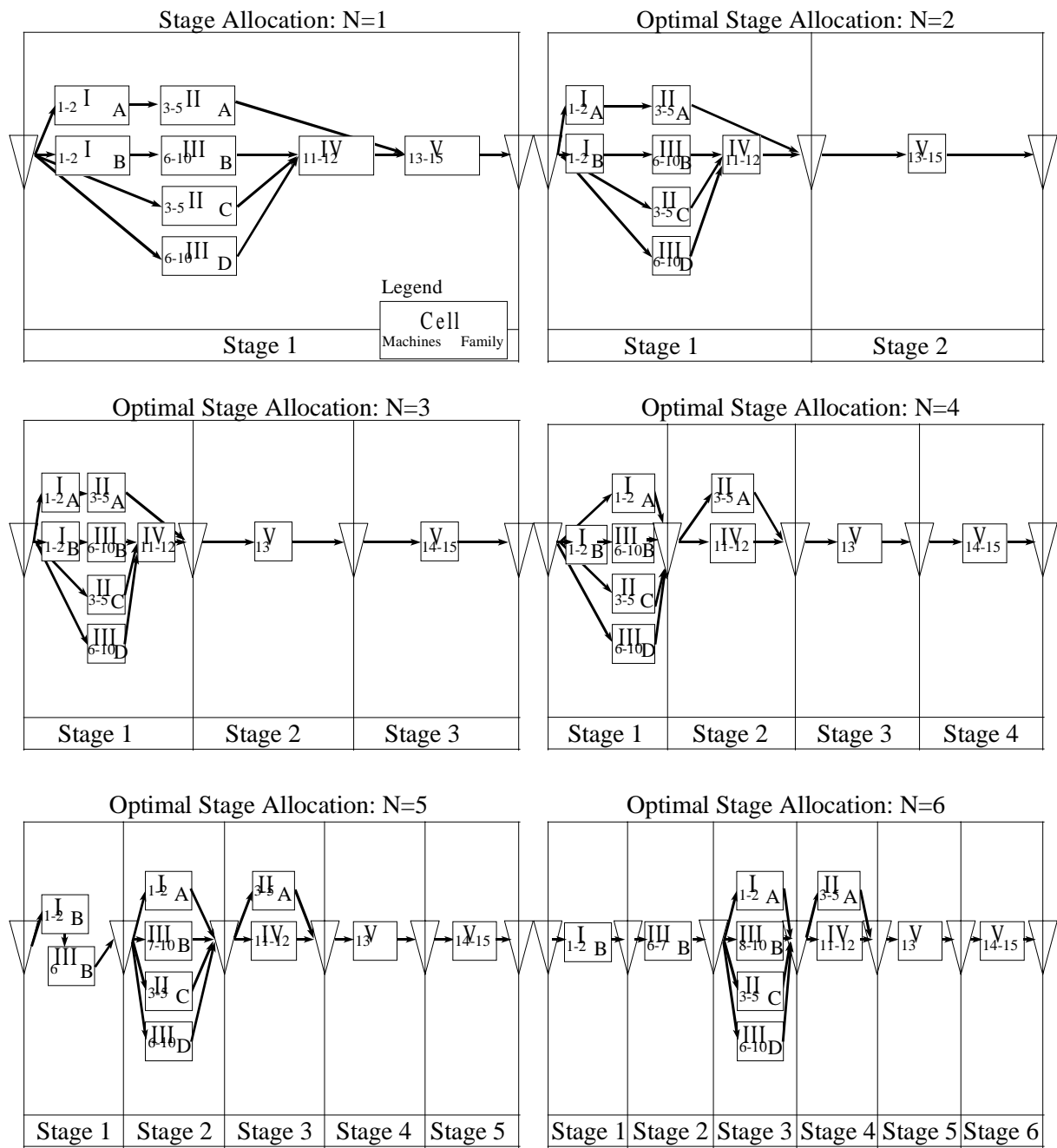

Figure B.1 Optimal stage allocation for production situation I (machine 13 bottleneck)

## Appendix C. Proof of equivalence between Formula 5.2 and 5.3

If overlapping production is not applied for a product ( $nb_h=1$ ), the Formula's 2 and 3 of Chapter Five are equivalent.

$$nb_h = 1 \Rightarrow \max_{i=1}^{n_j^h} \left[ r_{hi} + p_{hi} \cdot \left[ \frac{q_h}{m_{hi}} \right]^+ + \sum_{t=i+1}^{n_j^h} \left\{ p_{ht} \cdot \left[ \frac{q_h}{m_{ht} \cdot 1} \right]^+ \right\} \right] = \sum_{i=1}^{n_j^h} \left\{ d_{hi} + p_{hi} \cdot \left[ \frac{q_h}{m_{hi}} \right]^+ \right\}$$

Proof:

$$\begin{aligned} & \max_{i=1}^{n_j^h} \left[ r_{hi} + p_{hi} \cdot \left[ \frac{q_h}{m_{hi}} \right]^+ + \sum_{t=i+1}^{n_j^h} \left\{ p_{ht} \cdot \left[ \frac{q_h}{m_{ht} \cdot 1} \right]^+ \right\} \right] = \\ & \max \left( r_{h1} + \sum_{t=1}^{n_j^h} \left\{ p_{ht} \cdot \left[ \frac{q_h}{m_{ht}} \right]^+ \right\}, \max_{i=2}^{n_j^h} \left[ r_{hi} + \sum_{t=i}^{n_j^h} \left\{ p_{ht} \cdot \left[ \frac{q_h}{m_{ht}} \right]^+ \right\} \right] \right) = \\ & \max \left( s_{h1} + \sum_{t=1}^{n_j^h} \left\{ p_{ht} \cdot \left[ \frac{q_h}{m_{ht}} \right]^+ \right\}, \max \left( s_{h2}, r_{h1} + p_{h1} \cdot \left[ \frac{q_h}{m_{h1}} \right]^+ + \sum_{t=2}^{n_j^h} \left\{ p_{ht} \cdot \left[ \frac{q_h}{m_{ht}} \right]^+ \right\} \right), \right. \\ & \left. \max_{i=3}^{n_j^h} \left[ r_{hi} + \sum_{t=i}^{n_j^h} \left\{ p_{ht} \cdot \left[ \frac{q_h}{m_{ht}} \right]^+ \right\} \right] \right) = \\ & \max \left( s_{h1} + \sum_{t=1}^{n_j^h} \left\{ p_{ht} \cdot \left[ \frac{q_h}{m_{ht}} \right]^+ \right\}, \max \left( s_{h2} - p_{h1} \cdot \left[ \frac{q_h}{m_{h1}} \right]^+, s_{h1} \right) + \sum_{t=1}^{n_j^h} \left\{ p_{ht} \cdot \left[ \frac{q_h}{m_{ht}} \right]^+ \right\} \right), \\ & \left. \max_{i=3}^{n_j^h} \left[ r_{hi} + \sum_{t=i}^{n_j^h} \left\{ p_{ht} \cdot \left[ \frac{q_h}{m_{ht}} \right]^+ \right\} \right] \right) = \\ & \max \left( s_{h1} + \sum_{t=1}^{n_j^h} \left\{ p_{ht} \cdot \left[ \frac{q_h}{m_{ht}} \right]^+ \right\}, s_{h1} + \max \left( s_{h2} - p_{h1} \cdot \left[ \frac{q_h}{m_{h1}} \right]^+ - s_{h1}, 0 \right) + \sum_{t=1}^{n_j^h} \left\{ p_{ht} \cdot \left[ \frac{q_h}{m_{ht}} \right]^+ \right\} \right), \\ & \left. \max_{i=3}^{n_j^h} \left[ r_{hi} + \sum_{t=i}^{n_j^h} \left\{ p_{ht} \cdot \left[ \frac{q_h}{m_{ht}} \right]^+ \right\} \right] \right) = \\ & \max \left( d_{h1} + \sum_{t=1}^{n_j^h} \left\{ p_{ht} \cdot \left[ \frac{q_h}{m_{ht}} \right]^+ \right\}, d_{h1} + d_{h2} + \sum_{t=1}^{n_j^h} \left\{ p_{ht} \cdot \left[ \frac{q_h}{m_{ht}} \right]^+ \right\}, \dots, \left[ \sum_{t=1}^{n_j^h} \left\{ d_{ht} + p_{ht} \cdot \left[ \frac{q_h}{m_{ht}} \right]^+ \right\} \right] \right) = \\ & \sum_{i=1}^{n_j^h} \left\{ d_{hi} + p_{hi} \cdot \left[ \frac{q_h}{m_{hi} \cdot 1} \right]^+ \right\} \quad \text{as } d_{ht} \geq 0 \quad \forall t = 1..n_j^h \end{aligned}$$



## Appendix D. Exploring related problems with subbatches

In Chapter Five, Section § 5.4.3, we introduce a mathematical model that determines a period length  $P$  and a variable subbatch strategy in order to minimize the sum of holding costs, set-up costs and the costs of transfer of subbatches. Various branches of literature have paid attention to the problem of determining batch sizes. The modelling approaches for overlapping operations are all based on the initial work of Szendrovits (1975). The work of Muckstadt and Roundy (see e.g. Muckstadt and Roundy, 1993) gives attention to setting lot sizes in a series of production stages. We discuss a selection of the literature that provided us insight in the characteristics of a suitable solution approach for our mathematical model.

### D.I. Repetitive lots

Splitting a larger batch in equal sized subbatches results in repetitive lots at the various machines. Szendrovits (1975) was one of the firsts who addressed the effect of introducing subbatches on the traditional trade-off between cost factors in the economic production quantity theory. Graves and Kostreva (1986) developed an interesting procedure to determine the optimal number of subbatches. They use the ratio between the holding costs for in-process inventory and the transfer costs as an indicator, as shown in the following expression:

$$nb = \frac{Q}{\sqrt{r}} \cdot \sqrt{\frac{hc}{tc}} \quad (\text{Graves and Kostreva (1986)})$$

$nb$  number of subbatches

$Q$  optimal economic process batch quantity

$r$  production rate per day

$hc$  holding costs for one unit WIP per day

$tc$  transfer costs of one subbatch

The results of Graves and Kostreva are worthwhile to consider in developing a solution approach for our model, although their cost structure is not identical to ours.

Kropp and Smunt (1990) experimented with both unequal and equal sized subbatches in a deterministic flow shop for which optimal schedules could be generated and concluded that equal sized subbatches tend to be optimal or near optimal with respect to make span performance in the majority of the test problems. It is important to consider the efficiency of equal sized subbatches in our model in order to see if these conclusions hold also with respect to minimal total cost performance.

## D.II. Overlapping operations in a flow shop

The deterministic flow shop has often been subject of examination for job splitting. Long before Szendrovits developed his EOQ extension, Mitten (1958) had pointed to the use of overlapped production in a flow shop. He modelled the start of the batch at the next machine with start-to-start and finish-to-finish time lags (see Mitten, 1958) and generalised the results of Johnson (1954) through the introduction of start-start time lags in his classical algorithm on solving the two machine flow shop scheduling problem. For a further description of the use of time lags in flow shop scheduling research we refer to Riezebos, Gaalman, and Gupta (1995) and Riezebos and Gaalman (1998). Research on time lag modelling has not paid attention to the determination of the optimal time lag size, which would be useful in determining the number of subbatches.

## D.III. Lot streaming

The lot streaming problem for  $m$  machines (operations) is to find the optimal size of a fixed number of subbatches in the system such that a regular measure of performance, e.g. make span or flow time, is minimized. In the lot streaming problem, the number of subbatches is given and constant for each machine. Furthermore, the number of items per subbatch may vary, but the subbatches remain consistent on all subsequent machines, i.e. during processing at the various machines the subbatch is not further split up.

Baker and Pyke (1990) state that for the general lot streaming problem there is no known method of finding optimal solutions, but there do exist solution approaches that find optimal solutions for problems of restricted size (e.g.,  $m$ -machine, 2-subbatch problem; 2-machine,  $n$ -subbatch problem), analogous to results of general flow shop scheduling of Johnson (1954). The size of the first subbatch affects the start time at successive machines, and the size of the last subbatch affects the finish time of these machines. The optimal size of the subbatches is a function of the processing times and the sequence of processing at the machines. Potts and Baker (1989) show that the classical minimal make span flow shop scheduling results with respect to the optimality of permutation scheduling in case of four machines can be transformed to the lot streaming problem. Glass, Gupta and Potts (1992) prove the same for the case of three machines and other regular measures of performance. The use of equal sized subbatches will be optimal in these situations. We can generalize this to the statement that identical subbatch sizes will be optimal on both the first two and the last two operations of a job, due to the invertibility property known from general flow shop scheduling.

Trietsch (1989) applied a maximum on the transfer costs caused by the number of subbatches and minimized the make span with respect to this constraint. Note that our model does just the opposite: we minimize the total cost (including the transfer cost and the holding cost) with respect to a minimum period length, which can be transformed to a maximum make span.

## Appendix E. Progressive search heuristic

The *progressive search heuristic* finds an approximate solution for the mathematical model of Chapter Five. This model decides on a period length  $P$  and a variable subbatch strategy  $nb_{hi}$  and tries to minimize the resulting total costs. The required number of stages  $N$  has a strong impact on total inventory costs. The principles behind this heuristic are described in Section § 5.5.3.

Details of the progressive search heuristic are described in Section E.1 and Section E.2 describes its application on the data of the example problem of Section § 5.5.1. We present the results of the various steps in order to provide more insight in the way the heuristic works. Note that the progressive search heuristic consists of eight steps, including steps for initialization and output generation.

### E.I. Detailed description of progressive search heuristic

#### STEP 1 INITIALIZE

$$\begin{aligned}
 P_{\min} &\Rightarrow \max_{k=1}^K \left[ \frac{\sum_{h=1}^H \sum_{i^h \in k} s_{hi}}{1 - \sum_{h=1}^H \sum_{i^h \in k} \frac{p_{hi} \cdot D_h}{m_{hi}}} \right] && \{\text{capacity lowerbound on bottleneck}\} \\
 P &\Rightarrow \frac{P_{\min}}{(100 - MI)\%} && \{\text{aim for a bottleneck utilization } \leq (100 - MI)\% \} \\
 N_{up} &\Rightarrow 0 \\
 nb_{hi} &\Rightarrow 1 && \forall h = 1..H, i = 1..n_h \\
 \text{Totcost}[j] &\Rightarrow \infty && \forall j = 1..\infty
 \end{aligned}$$

#### STEP 2 Determine N

$$\begin{aligned}
 N &\Rightarrow N_{up} \\
 N_{up} &\Rightarrow \max_{h=1}^H \left[ \frac{TT_h}{P} \right]^+ && \{\text{largest number of stages necessary with length } P\}
 \end{aligned}$$

STEP 3 DETERMINE  $P_{(N_{up})}$

$$P_{(N_{up})} \Rightarrow \frac{\sum_{h=1}^H \sum_{i=1}^{n_h} (s_{hi} \cdot SC_{hi} + TC_{h'i})}{N_{up} \cdot \sum_{h=1}^H D_h \cdot HC_h} \quad \{nb_{hi} = 1 \quad \forall h = 1..H, i = 1..n_h\}$$

$$P \Rightarrow \max \left[ P_{\min}, P_{(N_{up})} \right] \quad \{\text{check capacity lowerbound}\}$$

STEP 4 Determine Cost of  $(P, N_{up})$

IF  $N \neq N_{up}$  THEN RETURN TO STEP 2  $\left\{ \begin{array}{l} \text{note that } TT_h \text{ is a function of } P, \\ \text{so if } P \text{ changes we have to iterate} \\ \text{until } N \text{ does not change anymore} \end{array} \right\}$

ELSE  $P_{\text{solution}}[N_{up}] \Rightarrow P$

$$\text{Totcost}[N_{up}] \Rightarrow P \cdot \left( N_{up} \cdot \sum_{h=1}^H \{D_h \cdot HC_h\} \right) + \frac{\sum_{h=1}^H \sum_{i=1}^{n_h} \{s_{hi} \cdot SC_{hi} + TC_{h'i}\}}{P}$$

STEP 5 WHILE  $(N > 1)$  AND  $(\text{Totcost}[N+1] \geq \text{Totcost}[N])$  DO

$$\left\{ \begin{array}{l} N \Rightarrow N-1 \\ P_{(N,nb)} \Rightarrow \frac{\sum_{h=1}^H \sum_{i=1}^{n_h} \{s_{hi} \cdot SC_{hi} + TC_{h'i} + TC''_{hi} \cdot (nb_{hi} - 1)\}}{N \cdot \sum_{h=1}^H \{D_h \cdot HC_h\}} \\ P \Rightarrow \max \left[ P_{\min}, P_{(N,nb)} \right] \\ \text{IF } \max_{h=1}^H [TT_h] > N \cdot P \text{ THEN GOTO STEP 6 } \left\{ \begin{array}{l} \text{enumerative search heuristic with known} \\ P, N, \text{ and initial subbatches } nb_{hi} \end{array} \right\} \\ \text{ELSE } P_{\text{solution}}[N] \Rightarrow P \\ \text{Totcost}[N] \Rightarrow P \cdot \left( N \cdot \sum_{h=1}^H \{D_h \cdot HC_h\} \right) + \frac{\sum_{h=1}^H \sum_{i=1}^{n_h} \{s_{hi} \cdot SC_{hi} + TC_{h'i} + TC''_{hi} \cdot (nb_{hi} - 1)\}}{P} \\ \text{RETURN TO START OF STEP 5 UNTIL WHILE LOOP ENDS} \end{array} \right.$$

GOTO STEP 8

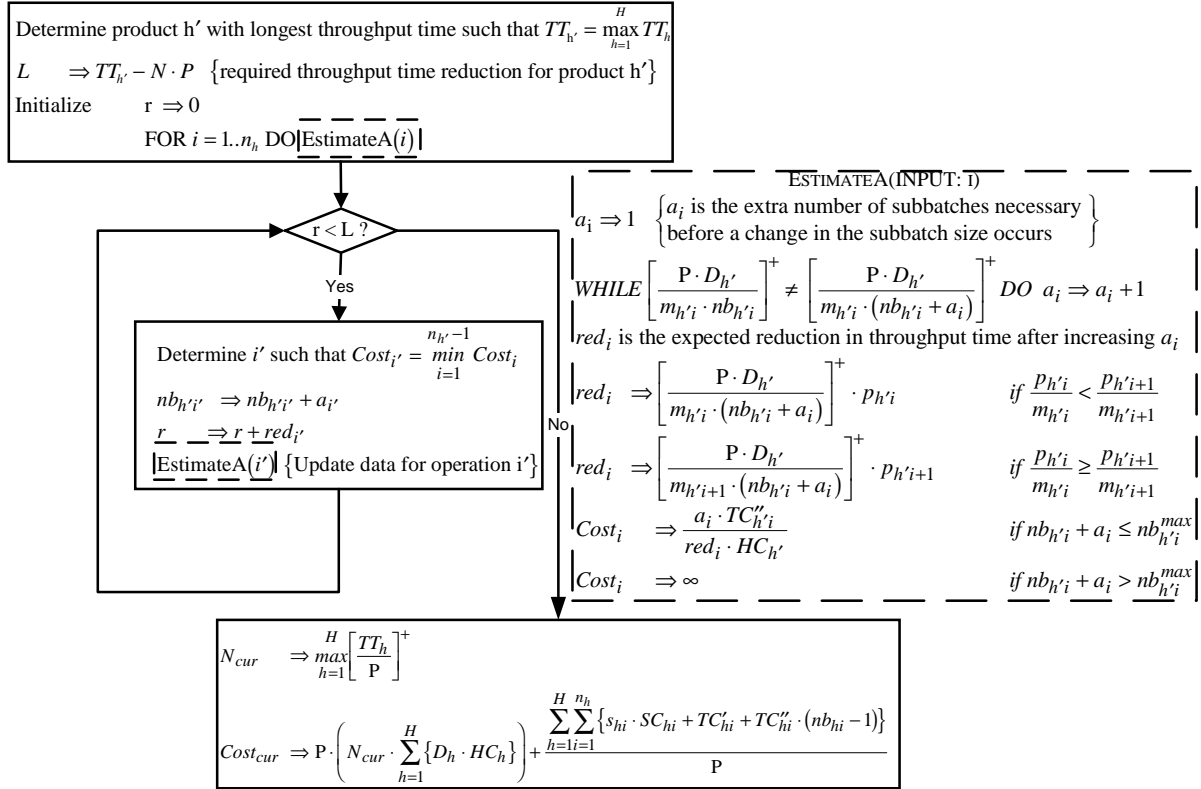
STEP 6 Enumerative search with known P, N, and initial value for  $nb_{hi}$ 

## STEP 7 UPDATE SOLUTION

IF  $Totcost[N_{cur}] > Cost_{cur}$  THEN  $Totcost[N_{cur}] \Rightarrow Cost_{cur}$   
 $P_{solution}[N_{cur}] \Rightarrow P$

$$P \Rightarrow \max \left[ P_{min}, P(N, nb) = \sqrt{\frac{\sum_{h=1}^H \sum_{i=1}^{n_h} \{s_{hi} \cdot SC_{hi} + TC_{hi}' + TC_{hi}'' \cdot (nb_{hi} - 1)\}}{N \cdot \sum_{h=1}^H \{D_h \cdot HC_h\}}} \right]$$

IF  $\{N_{cur} > N\}$  AND  $\left\{ Cost_{cur} - (N_{cur} - N) \cdot \sum_{h=1}^H \{D_h \cdot HC_h\} < Totcost[N_{cur}] \right\}$

THEN RETURN TO STEP 6 {re - iterate to further reduce throughput time }

ELSE RETURN TO STEP 5 {feasible solution obtained for N stages }

## STEP 8 OUTPUT OF PROGRESSIVE SEARCH HEURISTIC

$$Totcost[N^*] \Rightarrow \min_{N=1}^{N_{up}} Totcost[N]$$

$$P^* \Rightarrow P_{solution}[N^*]$$

## E.II. Application of progressive search heuristic on example problem

Step 1:	$P_{\min}$	= 0.01442 year (=30 hours)	
Step 2:	$N_{\text{up}}$	= 6;	
Step 3:	$P_{(N_{\text{up}}, \text{nb}=1)}$	= 0.01672	
	$P$	= $P_{(N_{\text{up}}, \text{nb}=1)}$	
Step 4:	Iterating step 2 and 3 results in the same $N_{\text{up}}$		
	$P_{\text{solution}}[N_{\text{up}}]$	= 0.01672	
	TotCost[ $N_{\text{up}}$ ]	= 1477	
	nb[ $N_{\text{up}}$ ]	= (1,1,1,1,1,1,1,1,1; 1,1,1,1,1,1,1,1)	
Step 5:	$N$	= 5	
	$P_{5, \text{nb}[N_{\text{up}}]}$	= 0.01832	
Step 6:	$L$	= 0.00214 ( $h^*=1$ )	
	$a_i$	= 1 $\forall i=1..n_1$	
	red $_i$	= 0.004807 $\forall i=1..n_1$	
	cost $_i$	= 20.8 $\forall i=1..n_1$	
	nb	= (2,1,1,1,1,1,1,1,1; 1,1,1,1,1,1,1,1)	
Step 7:	TotCost[5]	= 1370	$P_{5, \text{nb}} = 0.01862$
Step 5:	$N$	= 4	
	$P_{4, \text{nb}[5]}$	= 0.02081	
Step 6:	nb	= (2,2,2,2,1,1,1,1,1; 2,2,2,2,1,1,1,1)	
Step 7:	TotCost[4]	= 1353	$P_{4, \text{nb}} = 0.02298$
Step 5:	$N$	= 3	
	$P_{3, \text{nb}[4]}$	= 0.02654	
Step 6:	nb	= (2,2,2,2,2,2,2,2,1; 2,2,2,2,2,2,2,1)	
Step 7:	TotCost[3]	= 1273	$P_{3, \text{nb}} = 0.02883$
Step 5:	$N$	= 2	
	$P_{2, \text{nb}[3]}$	= 0.03531	
Step 6:	nb	= (3,3,3,3,3,2,2,2,1; 3,3,3,3,3,2,2,1)	$P_{2, \text{nb}} = 0.03897$
	nb	= (3,3,3,3,3,3,3,2,1; 3,3,3,3,3,3,3,1)	$P_{2, \text{nb}} = 0.04034$
	nb	= (4,3,3,3,3,3,3,2,1; 4,3,3,3,3,3,3,1)	$P_{2, \text{nb}} = 0.04134$
	nb	= (4,3,3,3,3,3,3,3,1; 4,4,4,3,3,3,3,1)	$P_{2, \text{nb}} = 0.04231$
	nb	= (4,4,3,3,3,3,3,3,1; 4,4,4,4,3,3,3,1)	
Step 7:	TotCost[2]	= 1255	$P_{2, \text{nb}} = 0.04263$
Step 5:	$N$	= 1	
	$P_{1, \text{nb}[2]}$	= 0.06029	
Step 6:	.... (18 full iterations)		
	nb	= (11,11,11,10,10,10,10,10,1; 14,14,14,12,12,12,12,1)	
Step 7:	Totcost[1]	= 1491	$P_{1, \text{nb}} = 0.10132$
Step 8:	Totcost[ $N^*$ ]	= $\min\{1491;1255;1273;1353;1370;1477\}= 1255$	
	$N^*$	= 2	
	$NB^*$	= (4,4,3,3,3,3,3,3,1; 4,4,4,4,3,3,3,1)	$P^* = 0.04263$

---

## Appendix F. Verification and validation of the simulation model

Verification and validation are important steps in the design of a simulation model. We will discuss both steps in the Sections F.I respectively F.II.

### F.I. Verification of the simulation model

In order to verify the simulation model, we have applied various verification methods. First, the structure of the simulation program represents the different processes that were distinguished. We have defined the following processes:

- a customer order arrival process
- a process that releases orders
- a process that generates production orders by exploding the Bill Of Material and that distributes these orders to the stages according to the stage allocation
- a process that controls the progress of each production order in a stage
- a process that monitors information for the stages and overtime control
- a process that represents the activities of a cell
- a process that represents the activities required to process a part
- a main process that controls the simulation run

The contents of these processes are networks of events. If an event is scheduled on the time axis, the activities that are mentioned will be performed. The use of processes facilitates model verification, as it is easy to compare the list of events in the processes with the verbal and schematic description in § 6.2.3 and Figure 6.10.

Another verification method that we applied is the use of debugging within Borland Pascal 7. This allowed us to process the simulation program step-by-step and determine programming errors. As a result of this verification analysis, we have reprogrammed specific error-sensitive procedures in DESIMP that we used to select orders for processing at machines.

We also applied verification methods that are available within DESIMP. The most important verification tool is the *Trace* that describes the events and activities that are being performed in chronological order. We have added relevant information for verification purposes to the standard contents of the *Trace* information. This extra information could be used to control the correct working of the reprogrammed order selection procedures. One of the main problems in our simulation program was the synchronization of several processes at one moment in time. Synchronization at a specific moment in time requires control of the sequence in which specific procedures are called, in order to guarantee that all activities are registered adequately and transferred to the next stage. Using the *Trace*, we were able to control the correct working of this synchronization.

The order arrival and release processes have been verified using animation. This allowed us to control if the release decision was correctly performed.

Finally, we have verified the model for various combinations of input parameters by generating random values for these parameters and analysing the behaviour of the simulated system during these experiments. DESIMP generates *Event lists*, reports the contents of *Queues* and updates results, such as utilization, overtime, and throughput times, during the experiment.

From our verification analysis, we conclude that the model behaves as we expect it to behave.

## F.II. Validation

It is important to pay attention to validation of the simulation study. However, this is not easily to accomplish in our case, as we are not able to compare the outcomes of the model with the real system. We have applied several validation tools in order to facilitate the correctness of the outcomes.

First, we have analysed the outcomes of the simulation studies in several ways. The quantitative output that is generated by DESIMP provides insight in both the mean values and the extremes of the performance measures and other output variables. Analysing the extreme value shows if outcomes are reported that will never occur in practice. However, note that we sometimes are interested in the behaviour of the system in situations that probably never will be tested in practice, because of the high costs of such policies. Hence, extreme outcomes in itself are not suspect, but analysing these extreme values may lead to the conclusion that there are errors in the model.

Another way of analysing the outcomes of the simulation model was to translate these outcomes to a Gantt chart for each period. The use of a different presentation language (graphical representation of the outcomes of the PBC system in terms of schedule per period) helps to clarify if the outcomes are as expected. Figure F.1 shows such a Gantt chart. It is generated by the simulation model by calling a library routine that we programmed for this purpose. It shows the loading of each machine and the stages from which they originate. The Gantt chart for the next period can be generated in order to control the progress of the jobs.

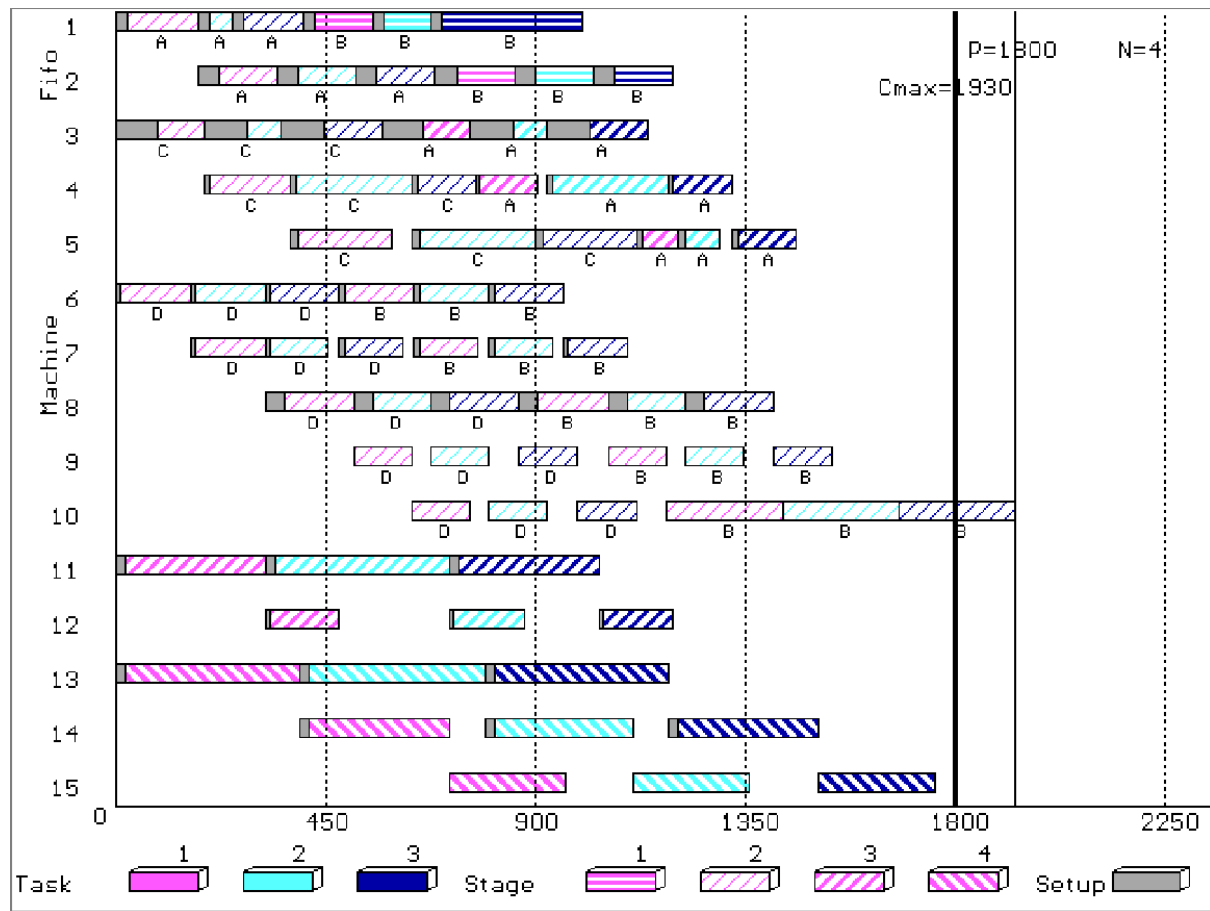

**Figure F.1** Gantt chart used for validation of the simulation model

The next validation tool that we used was discussing the outcomes with colleagues. The Gantt charts helped in these discussions. Keep in mind that the schedules need not be realistic in a sense that the schedule should be usable in practice. The model does not consider trade-offs that are important in practice, such as delaying the start of new work just before the end of the day, minimal time lags between successive operations, and so on. However, the model generates a non-delay schedule that can function as an indication of a real lowerbound on the make span performance of the system.

Finally, we have compared our simulation model with the description of the production system that was simulated by Steele, Berry and Chapman (1995), and that was also used in Steele and Malhotra (1997). We have also analysed their results for comparable situations ( $N=4$ , weak cell position=5, period length = 4 days), but our fundamental choice to model the basic unicycle PBC system that does not transfer work to the next period but finishes it within overtime makes it difficult to compare the results. However, the general pattern of their results can also be found in our experiments.

An important aspect of validation is the length of the warming-up period. We distinguish between the warming-up during a simulated PBC period and the length of the start-up interval before the outcomes of the simulation study are reported. The start-up interval has to be such that the system is in steady state. This state is reached by our system after  $N$  production periods, as the final stage  $N$  releases work to the system that was arrived at the system just before the first period. Therefore, the start-up period has to be greater than  $N+1$ . We have taken  $N+3$  as start-up period and apply a test in the program whether this state has been reached. We do not consider a warming-up period, as we examine a terminating simulation system. The behaviour at both the start and the end of the period can be very important for the outcomes. The warming-up during a period is therefore important, as we are interested in the start/finish effect.

---

## Appendix G. Modifications in progressive search heuristic

Chapter Seven describes the application of the progressive search heuristic in determining a configuration for a PBC system. The progressive search heuristic of Chapter Five requires some modifications in order to be able to determine a PBC configuration for the product structure of production situation I. Other modifications are required in order to test the proposed configuration in the simulation model of Chapter Six. Recall that the progressive search heuristic has been applied on a set of problems with a relatively simple structure, while production situation I resembles a more realistic situation.

Section G.I discusses modifications in the lowerbounds on period length  $P$  that the progressive search heuristic applies. Section G.II describes differences in modelling completion time. Section G.III presents modifications because of differences in the cost structure of both models.

### G.I. Modifications in lowerbounds on $P$

The progressive search heuristic applies two lowerbounds on the period length  $P$ : a longest-path oriented lowerbound that determines  $P$  according to the product with the longest throughput time, and a load oriented lowerbound that determines the minimal period length for which enough time in a period remains to complete the required operations. The following problems occur which make modifications in the heuristic necessary:

The *longest-path oriented lowerbound* in the heuristic presumes a linear product structure. However, the product structure in production situation I is not linear but convergent, as is quite normal in assembly operations. A convergent product structure consists of multiple paths that all lead to the same final operations. Figure G.1 shows such a convergent<sup>1</sup> product structure.

---

<sup>1</sup> This notion of convergence can with the use of graph theory be stated more formally as: The directed acyclic graph  $G$  containing vertices  $X$  (operations) and arcs  $A$  (finish to start precedence relationships between two different vertices) is convergent if the outdegree of each vertex is one except for the only sink vertex that has no successor at all (outdegree = zero), while the indegree of all vertices is at least one except for the various source vertices that have no predecessors at all (indegree = zero). A path in a convergent directed acyclic graph consists of a sequence of adjacent vertices. See for an introduction of graph theory Minieka (1978).

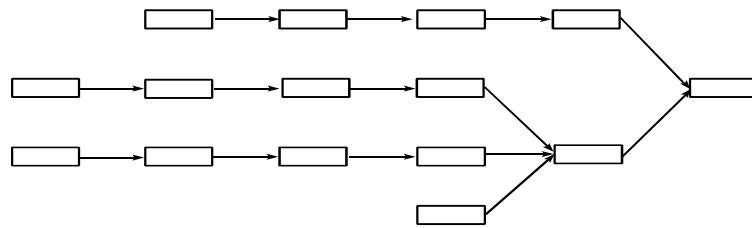

**Figure G.1 Convergent product structure**

We are interested in the *longest path* in the convergent product structure of each product in production situation I. However, which path will be longest may depend on the subbatch strategy, on the processing time and set-up time of each operation, on the volume that has to be produced in a period and hence on the period length.

We have modified the progressive search heuristic such that we added an initial step in which we determine the operations that are on the longest path in case no extra transfer batches are used. These are the only operations we use in our method for determining the period length  $P$ , number of stages  $N$ , and subbatch strategy<sup>2</sup>. The main problem with this approach is the effect of a proposed subbatch strategy, which indeed might shorten this path, but may have no effect at all on the other paths in the product structure. Often this is no problem, as other paths will not require overlapping production at all if they carefully distribute the co-ordination efforts over the various paths. However, the proposed subbatch strategy may lead to another path becoming longest path. This is not visible for the progressive search heuristic if it is modified as proposed. Further improvements of the modification would have been possible, but were not necessary for achieving our research objective. Therefore, we restricted ourselves to this modification and checked the data of production situation I whether the other paths in the product structure could be shortened. We conclude that there are no problems with respect to the possibility of reducing these other paths through an appropriate subbatch strategy if required by the heuristic.

The costs of shortening these parallel paths are not included in the total costs that our progressive search heuristic reports for a specific configuration of the PBC system. Shorter period lengths or lower number of stages will therefore seem to be more attractive to the progressive search heuristic than we may expect when we test these configurations with the original product structures in our simulation model. In order to count for this effect, we have introduced higher transfer batch costs and holding costs per operation in the progressive search heuristic. This compensates for the smaller number of operations that it considers.

<sup>2</sup> For the data of production situation I, the selection of operations that belong to the longest path was not influenced by the volume that had to be produced in a period. Neither were there differences between the products with respect to the machines that were involved in performing the longest path operations.

The *load oriented lowerbound* in the heuristic also presumes a linear product structure. Operations that require capacity at a specific resource are on the routing of a product and this routing has a linear structure. However, in production situation I operations on non-critical paths do also require set-up time and processing time on the same resources as operations on the longest path. Therefore, we modified the progressive search heuristic to include the required capacity of these operations in determining the load oriented lowerbound. This results in a more realistic minimal period length determination.

If we are able to apply a modified progressive search heuristic on the data of production situation I, we will obtain a period length  $P$ , number of stages  $N$ , a subbatch policy, and the expected total costs that will be incurred with such a PBC configuration. These parameters of the PBC system configuration cannot directly be imported into the simulation model. First, we have to assure that the data that is used in both models is in accordance.

Recall that both models are being designed with a different purpose. The progressive search heuristic had to find an approximate solution for the mathematical model presented in Chapter Five, which included a variable subbatching strategy and no predetermined allocation of operations to stages. The simulation model is being designed for evaluating several combinations of  $N$  and  $P$  and other PBC design parameters, such as the equal subbatch strategy, stage co-ordination policy, and cell priority rules, given an allocation of operations to stages. It shows the significance of main and interaction effects of these design factors on PBC system performance. In order to show significance of these effects, experiments with a variable subbatch strategy were not necessary, and they would have increased the amount of calculations strongly. The simulation model is hence not able to simulate configurations with a variable subbatch strategy.

The attempt to use the results of one model as input in the other makes it further necessary to explore the differences between both models in terms of cost structure and behaviour with respect to the sequencing of activities.

## G.II. Modifications in modelling completion time

The progressive search heuristic models the expected completion time of a product according to the formula  $TT_h$  (Expression (12) in Chapter Five), corrected for a machine interference parameter  $MI$  (Expression (10)). Two main modifications in the heuristic were necessary:

First, Expression (12) in Chapter Five provides a formula for  $TT_h/MI$  that allows each product to have a different number of subbatches per operation. The simulation results for production situation I that we have presented in Chapter Six are all based on an equal number of subbatches strategy: equal for all products and all operations. We would like to compare the results of the configuration proposed by the progressive search heuristic with the results of the

corresponding original PBC configuration from Chapter Six. We simulate the system with the new P and N for all equal subbatch strategies that can be deduced from the specified subbatch strategy. As we used a maximum of four subbatches in the simulation experiments, we modified the progressive search heuristic such that each operation could have no more than four subbatches.

Second, the parameter MI has to be set in order to obtain a configuration of the PBC system. We have taken into account that this parameter needs to be smaller than one in order to accomplish for three important modelling differences between both models:

First, the progressive search heuristic assumes that the set-up of the machine that is required for the next operation on the path can be performed in parallel with processing the first subbatch at the preceding operation. The simulation model assumes that a machine decides about the required set-up as soon as the first transfer batch arrives. This lengthens the required throughput time in the simulation model and can be corrected with a parameter choice  $MI < 1$  in the progressive search heuristic.

Second, the simulation model applies a predetermined allocation of operations to stages that may differ from the allocation that best suites the proposed configuration of the PBC system originating from the progressive search heuristic. The results of testing the proposed configuration will therefore be less positive than expected in the heuristic in terms of required amount of overtime work. A parameter choice of  $MI < 1$  may compensate for this effect.

Finally, the nearer the proposed period length is to one of the lowerbounds in the progressive search heuristic, the more sensitive it is to the assumptions behind these lowerbounds. If the period length is near a lowerbound, we cannot expect that it will be sufficiently long to avoid overtime work. For the path oriented lowerbound, we can choose a machine interference correction factor  $MI < 1$  as discussed before. For the load oriented lowerbound in the progressive search heuristic, we can apply the same reasoning. This lowerbound assumes that a resource never has to wait on the arrival of a batch that requires capacity of this resource. If preceding operations at other resources have to be performed in the same period, a start/finish delay is introduced. This waiting time can be accomplished for in the load oriented lowerbound by requiring that the product of the period length P and a correction factor has to exceed the load oriented lowerbound. Both lowerbounds use the same value for the correction factor.

### G.III. Modifications in cost structure

The progressive search heuristic estimates the total costs *per year* for various configurations of the PBC system. As we used in our simulation experiments a fixed throughput time of  $T=7200$  minutes and computed costs over this period, we have modified the progressive search heuristic such that it expresses the cost of a solution per  $T=7200$  minutes<sup>3</sup>. The value for  $P$  is now also expressed as a fraction of  $T=7200$ .

The progressive search heuristic assumes that total costs consist of three factors: echelon holding costs, set-up costs, and transfer costs. The costs of overtime are not taken into account, as it assumes that no overtime will occur with the configuration that is being determined. In the simulation study, we have used a finite overtime cost factor. The progressive search heuristic is not modified for this, so it will not try to use overtime work because of the smaller cost factor.

The cost structure for transfer batches is identical in both models and the same holds true for the set-up costs. However, the calculation of the costs of holding inventory in the progressive search heuristic is very different from the calculation in the simulation model. The heuristic assumes that all material on average is available half way the first stage and stays therefore  $N$  periods of length  $P$  in the system. It computes the echelon holding costs over this period. The simulation model considers more details on the exact timing of operations and on the stage in which bought material is required. Simulated holding costs depend therefore on the allocation of operations to the stages and the timing of these operations. A higher number of stages in the simulation generally causes an echelon holding cost decrease even if the product of  $N \cdot P$  remains equal. This is contrary to the results of the heuristic, which will report identical holding costs as long as  $N \cdot P$  remains constant. As these holding cost differences cannot be corrected through a modification of the progressive search heuristic, we have determined values for the holding cost factor that result in almost equal total holding costs for a random selection of cases.

Having described all these modifications, we return to discussion on the applicability of the progressive search heuristic to the problem of determining a configuration for a PBC system in production situation I. The two models are being developed with a different purpose and therefore do not resemble the same structure. We have proposed several modifications of both the heuristic and the input (cost) data in order to be able to use the results of one model as input in the other model and to compare the results with other simulated configurations. With these modifications, we test the proposed PBC configuration resulting from the progressive search heuristic. Section § 7.1 describes the results of these tests.

---

<sup>3</sup> If we simulate PBC configurations with  $N \cdot P < 7200$  minutes, we recalculate the reported costs for a standard period of 7200 minutes.



## REFERENCES

- Ahmadi, R.H., Wurgaft, H., 1994, Design for synchronized flow manufacturing, *Management science* 40, 11, 1469-1483
- Alford, H., 1994. Cellular manufacturing: the development of the idea and its application, *New technology, work and employment* 9, 1, 3-18
- APICS, 1980, Apics dictionary (edited by Cox, J.F., Blackstone, J.H., Spencer, M.S.), American production and inventory control society, Falls Church, VA.
- Babbage, C., 1832, *On the economy of machinery and manufacturers*, Carey & Lea, Philadelphia.
- Baker, K.R., 1974, *Introduction to sequencing and scheduling*, Wiley, New York.
- Baker, K.R., Pyke, D.D., 1990, Solution procedures for the lot-streaming problem, *Decision sciences* 21, 475-491
- Banerjee, S.K., 1997, Methodology for integrated manufacturing planning and control systems design, 54-88, in: Artiba, A., Elmaghraby, S.E., (eds), *The planning and scheduling of production systems, methodologies and applications*, Chapman & Hall, London.
- Bauer, A., Bowden, R., Browne, J., Duggan, J., Lyons, G., 1991, *Shop floor control systems, from design to implementation*, Chapman & Hall, London.
- Bertrand, J.W.M., Wortmann, J.C., Wijngaard, J., 1990a, *Productiebeheersing en material management* (in Dutch), Educatieve Partners Nederland (Stenfert Kroese), Houten.
- Bertrand, J.W.M., Wortmann, J.C., Wijngaard, J., 1990b, *Production control, a structural and design oriented approach*, Elsevier, Amsterdam.
- Bond, T.C., 1993, An investigation into the use of OPT production scheduling, *Production planning and control* 4, 4, 399-406
- Borgen, E., 1996, Production management principles in newspaper pre-press production, *Production planning and control* 7, 1, 96-98
- Botter, C. (red), 1967, *Verkenning van de industriële logistiek (Plannings- en bevoorradingsvraagstukken)* (in Dutch), Philips, Afdeling Technische Efficiency en Organisatie, Materials management en planning.
- Boucher, T.O., 1984, Lot sizing in group technology production systems, *International journal of production research* 22, 85-93
- Browne, J., Harhen, J., Shivnan, J., 1988, *Production management systems, a CIM perspective*, Addison-Wesley, Harlow.
- Browne, J., Harhen, J., Shivnan, J., 1996, *Production management systems, an integrated perspective*, 2<sup>nd</sup> ed., Addison-Wesley, Harlow.
- Buitenhuis, C.H., Nederend, W.G. van het, 1969, Een cyclisch besturingssysteem voor samengestelde producten, 152-171 (in Dutch) in: Ham, C.J. van, (red), 1969, *Planning en besturing in de praktijk*, Marka.
- Burbidge, J.L., 1958, A new approach to production control, *The institution of production engineers journal*, May 1958.

- Burbidge, J.L., 1960, *Standard Batch Control*, MacDonald and Evans, Plymouth.
- Burbidge, J.L., 1962, *The principles of production control*, MacDonald and Evans, Plymouth.
- Burbidge, J.L., 1971, *Production planning*, Heinemann, London.
- Burbidge, J.L., 1975a, *The introduction of group technology*, Heinemann, London.
- Burbidge, J.L., 1975b, *Final report on the study of the effects of group technology production methods on the humanisation of work*, Turin international centre, Turin.
- Burbidge, J.L., 1979, *Group technology in the engineering industry*, Mechanical Engineering Publications Ltd., London.
- Burbidge, J.L., 1988, Operation scheduling with GT and PBC, *International journal of production research* 26, 3, 429-442
- Burbidge, J.L., 1989a, *Production flow analysis for planning group technology*, Clarendon Press, Oxford.
- Burbidge, J.L., 1989b, A synthesis for success, *Manufacturing engineer*, nov 1989, 99-102.
- Burbidge, J.L., 1990, Production control: a universal conceptual framework, *Production planning and control* 1, 1, 3-16
- Burbidge, J.L., 1993, Group Technology (GT): Where do we go from here?, 541-552, in: Pappas, I.A., Tsiopoulos, I.P. (eds), *Advances in production management systems*, Elsevier, IFIP, Amsterdam.
- Burbidge, J.L., 1996, *Period Batch Control*, Oxford University Press, Clarendon Press, Oxford.
- Burbidge, J.L., Partridge, J.T., Aitchison, K., 1991, Planning group technology for Davy Morris using production flow analysis, *Production planning and control* 2, 1, 59-72
- Camp, W.E., 1922, Determining the production order quantity, *Management engineering* 2, 17-18
- Carlier, J., 1982, The one-machine sequencing problem, *European journal of operational research* 11, 42-47
- Clarke, G., Wright, J.W., 1963, Scheduling of vehicles from a central depot to a number of delivery points, *Operations research* 11, 568-581
- Conway, R.W., Maxwell, W.L., Miller, L.W., 1967, *Theory of scheduling*, Addison-Wesley, Reading, MA.
- Dale, B.G., Russell, D., 1983, Production control systems for small group production, *Omega, the international journal of management science* 11, 2, 175-185
- Forrester, J.W., 1961, *Industrial dynamics*, MIT Press, Boston.
- Fox, R.E., 1984, OPT vs. MRP: thoughtware vs. software, part II, *Inventories and production magazine*, jan/feb 1984, 13-17
- French, S., 1992, *Sequencing and scheduling: an introduction to the mathematics of the job shop*, Wiley, New York.
- Gallagher, C.C., Knight, W.A., 1986, *Group technology production methods in manufacture*, Ellis Horwood Limited, Chichester.
- Gantt, H.L., 1918, Organizing for Work, *Industrial management* 58, August 1918, 89-93, also published in Gantt, H.L., 1919, *Organizing for work*, Harcourt, Brace and Howe, New York
- Garza, O., Smunt, T.L., 1991, Countering the negative impact of intercell flow in cellular manufacturing, *Journal of operations management* 10, 1, 92-117

- Garza, O., Smunt, T.L., 1994, Reducing flow between manufacturing cells: a sensitivity analysis, *International journal of production research* 32, 9, 2131-2147
- Gigli, R.J., 1947, *Material control reference book*, Associated Industrial Consultants, July 1947.
- Glass, C.A., Gupta, J.N.D., Potts, C.N., 1992, Lot streaming in three-stage production processes, Working paper.
- Goldratt, E., 1980, Optimized production timetables: a revolutionary program for industry, *APICS 23rd annual international conference proceedings*, 172-176
- Goldratt, E., 1981, The unbalanced plant, *APICS 1981 conference proceedings*, 195-199
- Goyal, S.K., Satir, A.T., 1989, Joint replenishment inventory control: deterministic and stochastic models, *European journal of operational research* 38, 2-13
- Graves, S.C., Kostreva, M.M., 1986, Overlapping operations in material requirements planning, *Journal of operations management* 6, 3, 283-294
- Greene, T.J., Sadowski, R.P., 1983, Cellular manufacturing control, *Journal of manufacturing systems* 2, 2, 137-146
- Greene, T.J., Sadowski, R.P., 1986, A mixed integer program for loading and scheduling multiple flexible manufacturing cells, *European journal of operational research* 24, 379-386
- Habich, M., 1990, *Handlungssynchronisation autonomer dezentraler Dispositionszentren in flexiblen Fertigungsstrukturen, ein beitrag zur Integration dezentraler Leitstände in PPS-Systeme*, Ph D Thesis (in German), Ruhr-Universität Bochum
- Hackman, J.R., 1982, The design of work teams, in: Lorsch, J.W., (ed), *The handbook of organizational behavior*, Englewood Cliffs, NJ.
- Hall, R.W., 1987, *Attaining manufacturing excellence*, Dow Jones-Irwin, Homewood.
- Hall, R.W., 1988, Cyclic scheduling for improvement, *International journal of production research* 26, 3, 457-472
- Ham, C.J. van, (red), 1969, *Planning en besturing in de praktijk* (in Dutch), Marka.
- Harris, F.W., 1913, How many parts to make at once, *Factory, the magazine of management* 10, 2, 135-136, 152, February 1913
- Hill, T., 1991, *Production/operations management, text and cases*, 2<sup>nd</sup> ed, Prentice Hall, Hemel Hempstead.
- Hoekstra, S., Romme, J.H.J.M., 1985, *Op weg naar integrale logistieke structuren* (in Dutch), Kluwer, Deventer.
- Hyer, N.L., Wemmerlöv, U., 1982, MRP/GT: A framework for production planning and control of cellular manufacturing, *Decision sciences* 13, 681-701
- Ivanov, E.K., 1968, *Group production organization and technology*, Business Books Ltd, London.
- Jamshidi, H., Browne, R.A., 1993, Development of production cycles for group technology environment with the Wagner-Whitin algorithm, *Computers industrial engineering* 24, 2, 199-207
- Johnson, S.M., 1954, Optimal two and three stage production scheduling with set-up times included, *Naval research logistics quarterly* 1, 61-68

- Kaku, B.K., Krajewski, L.J., 1995, Period batch control in group technology, *International journal of production research* 33, 1, 79-99
- Kanet, J.J., 1986, Toward a better understanding of lead times in MRP systems, *Journal of operations management* 6, 3, 305-315
- Kelley, J.E., Walker, M.R., 1959, Critical path planning and scheduling, *Proceedings of the eastern joint computer conference*, Boston, 160-173
- Krajewski, L.J., King, B.E., Ritzman, L.P., Wong, D.S., 1987, Kanban, MRP and shaping the manufacturing environment, *Management science* 33, 39-57
- Kropp, D.H., Smunt, T.L., 1990, Optimal and heuristic models for lot splitting in a flow shop, *Decision sciences* 21, 691-709
- Kuipers, H., Amelsvoort, P. van, 1990, *Slagvaardig organiseren, inleiding in de sociotechniek als integrale ontwerpleer* (in Dutch), Kluwer Bedrijfswetenschappen, Deventer.
- Land, M.J., Gaalman, G.J.C., 1998, The performance of workload control concepts in job shops: improving the release method, *International journal of production economics* 56-57, 347-364
- Lee, T.-E., Posner, M.E., 1997, Performance measures and schedules in periodic job shops, *Operations research* 45, 1, 72-91
- Leeuw, A.C.J. de, 1986, *Organisaties: management, analyse, ontwerp en verandering: een systeemvisie* (in Dutch), van Gorcum, Assen.
- LINGO manual, 1998, accompanied by: Schrage, L., 1998, Optimization modeling with LINGO, Lindo Systems Inc., Chicago.
- Loersch, A.G., Muckstadt, J.A., 1994, An approach to production planning and scheduling in cyclically scheduled manufacturing systems, *International journal of production research* 32, 4, 851-871
- Luss, H., 1989, Synchronized manufacturing at final assembly and feeder shops, *International journal of production research* 27, 8, 1413-1426
- Megens, E., 1999, *Organisatie en technologie in logistieke besturing* (in Dutch), Ph. D. Thesis, University of Twente.
- Melby, O.H., 1994, *Innføring av Period Batch Control I Verkstedbedrift (Implementation of period batch control in a job shop)* (in Norse), Institutt for Produksjons- og Kvalitetsteknikk, Fakultet for Maskinteknikk, Norges Tekniske Høgskole, Univesitetet I Trondheim.
- Miltenburg, J., Wijngaard, J., 1991, Designing and phasing in just-in-time production systems, *International journal of production research* 29, 1, 115-131
- Miltenburg, J., Zhang, W., 1991, A comparative evaluation of nine well-known algorithms for solving the cell formation problem in group technology, *Journal of operations management* 10, 1, 44-71
- Minieka, E., 1978, *Optimization algorithms for networks and graphs*, Marcel Dekker Inc, New York.
- Mitra, D., Mitrani, I., 1990, Analysis of a kanban discipline for cell co-ordination in production lines I, *Management science* 36, 12, 1548-1566

- Mitranov, S.P., 1959, *The scientific principles of group technology*, Lenizdat (National Lending Library, England, 1966)
- Mitten, L.G., 1958, Sequencing n jobs on two machines with arbitrary time lags, *Management science* 5, 293-298
- Monden, Y., 1983, *Toyota production system*, Industrial engineering and management press, Institute of Industrial Engineers, Atlanta.
- Monhemius, W., 1989, Historische ontwikkeling van de industriële logistiek (in Dutch), valedictory lecture University of Eindhoven, 28 april 1989.
- Muckstadt, J.A., Roundy, R.O., 1993, Analysis of multistage production systems, 59-132, in: Graves, S.C., Rinnooy Kan, A.H.G., Zipkin, P.H., (eds), *Logistics of production and inventory*, (Handbooks in operations research and management science, Vol. 4, North Holland, Amsterdam.
- Muth, J.F., Thompson, G.L., 1963, *Industrial Scheduling*, Prentice-Hall, Englewood Cliffs.
- New, C.C., 1977, *Managing the manufacture of complex products: co-ordinating multi-component assembly*, Business books communica europe, London.
- Olorunniwo, F.O., 1996, Changes in production planning and control systems with implementation of cellular manufacturing, *Production and inventory management journal*, first quarter, 65-69
- Olorunniwo, F.O., Udo, G., 1999, Impact of sociotechnical factors on cellular manufacturing implementation, *Proceedings DSI*, 1385-1387
- Orlicky, J., 1975, *Material requirements planning*, McGraw-Hill, New York.
- Ouenniche, J., Boctor, F., 1998, Sequencing, lot-sizing and scheduling of several products in job shops: the common cycle approach, *International journal of production research* 36, 4, 1125-1140
- PERT, 1958, *Program Evaluation Research Task, Phase I Summary Report*, vol. 7, Special projects office, Bureau of Ordinance, U.S. Department of the Navy, Washington, 646-669.
- Petrov, V.A., 1966, *Planirovanie Potochno-Gruppovogo Proizvodstva*, translated by E. Bishop in English in: 1968, *Flowline group production planning*, Business Publ., London.
- Potts, C.N., Baker, K.R., 1989, Flow shop scheduling with lot streaming, *Operations research letters* 8, 297-303.
- Rachamadugu, R., Tu, Q., 1997, Period batch control for group technology - an improved procedure, *Computers industrial engineering* 32, 1, 1-7
- Rees, L.P., Huang, P.Y., Taylor, B.W., 1989, A comparative analysis of an MRP lot-for-lot system and a kanban system for a multistage production operation, *International journal of production research* 27, 8, 1427-1443
- Riezebos, J., Gaalman, G.J.C., 1998, Time lag size in multiple operations flow shop scheduling heuristics, *European journal of operational research* 105, 1, 72-90
- Riezebos, J., Gaalman, G.J.C., Gupta, J.N.D., 1995, Flow shop scheduling with multiple operations and time lags, *Journal of intelligent manufacturing* 6, 105-115
- Rodammer, F.A., Preston White, K., 1988, A recent survey of production scheduling, *IEEE transactions on systems, man, and cybernetics* 18, 6, 841-851
- Scholl, A., 1995, *Balancing and sequencing of assembly lines*, Physica Verlag, Heidelberg.

- Schonberger, R.J., 1982, *Japanese manufacturing techniques*, The Free Press, MacMillan, New York.
- Schonberger, R.J., 1983, Selecting the right manufacturing inventory system: western and japanese approaches, *Production and inventory management*, no 2, 33-44
- Senge, P., 1990, *The fifth discipline: the art and practice of the learning organisation*, Doubleday Dell, New York.
- Shtub, A., 1990, Lot sizing in MRP/GT systems, *Production planning and control* 1, 1, 40-44.
- Sitter, L.U. de, 1998, *Synergetisch produceren, human resource mobilisation in de produktie: een inleiding in structuurbouw* (in Dutch), van Gorcum, Assen.
- Slomp, J., 1993, *Production control for flexible manufacturing systems, an application oriented approach*, Ph D Thesis, University of Twente.
- Sridharan, V., Berry, W.L., 1990, Master production scheduling make-to-stock products: a framework for analysis, *International journal of production research* 28, 3, 541-558
- Steele, D.C., 1998, Period batch control systems for cellular manufacturing, 309-320 in: Suresh, N.C., Kay, J.M. (eds), *Group technology and cellular manufacturing: state-of-the-art synthesis of research and practice*, Kluwer Academic Publishers, Boston.
- Steele, D.C., Berry, W.L., Chapman, S.N., 1995, Planning and control in multi-cell manufacturing, *Decision sciences* 26, 1, 1-34
- Steele, D.C., Malhotra, M.K., 1994, Factors affecting performance of period batch control systems in cellular manufacturing, *Proceedings 25<sup>th</sup> Decision Science Institute meeting, Hawaii*, 1699-1701.
- Steele, D.C., Malhotra, M.K., 1997, Factors affecting performance of period batch control systems in cellular manufacturing, *International journal of production research* 35, 2, 421-446
- Steudel, H.J., Desruelle, P., 1992, *Manufacturing in the nineties, how to become a mean, lean, world-class competitor*, Von Nostrand Reinhold, New York.
- Stokking, E.J., 1996, Desimp "Discrete Event SIMulation in Pascal" versie 1.5c, manual (in Dutch), University of Groningen
- Sugimori, Y., Kusunoki, K., Cho, F., Uchikawa, S., 1977, Toyota production system and kanban system: materialization of just-in-time and respect for human system, *International journal of production research* 15, 6, 553-564
- Suresh, N.C., 1979, Optimizing intermittent production systems through group technology and an MRP system, *Production and inventory management journal* 20, 4, 76-84
- Suresh, N.C., Meredith, J.R., 1994, Coping with the loss of pooling synergy in cellular manufacturing systems, *Management science* 40, 4, 466-483
- Susman, G.I., 1976, *Autonomy at work, a sociotechnical analysis of participative management*, Praeger publishers, New York.
- Szendrovits, A.Z., 1975, Manufacturing cycle time determination for a multistage economic production quantity model, *Management science* 22, 298-308
- Takkenberg, C.A.Th., 1983, *Planning en methode van onderzoek*, Ph D Thesis (in Dutch), University of Groningen.
- Taylor, F.W., 1903, *Shop management*, page 98-99, reprinted in: Taylor, F.W., 1947, *Scientific management*, Harper & Brothers, New York.

- Thompson, J.D., 1967, *Organizations in action, social science bases of administrative theory*, McGraw-Hill, New York.
- Trietsch, D., 1989, Polynomial transfer lot sizing techniques for batch processing on consecutive machines, *Technical report NPS-54-89-011 Naval Postgraduate school, Monterey, California, USA*.
- Vakharia, A.J., Wemmerlöv, U., 1995, A comparative investigation of hierarchical clustering techniques and dissimilarity measures applied to the cell formation problem, *Journal of operations management* 13, 117-138
- Vollmann, T.E., Berry, W.L., Whybark, D.C., 1997, *Manufacturing planning and control systems*, 4<sup>th</sup> ed., Irwin / McGraw-Hill, New York.
- Wagner, H.M., Whitin, T.M., 1958, Dynamic version of the economic lot size model, *Management science* 5, october, 89-96
- Wakker, A.M. van de, 1993, *Throughput time control and due date reliability in tool & die shops*, Ph D Thesis, University of Eindhoven
- Wein, L.M., Chevelier, P.B., 1992, A broader view of the job-shop scheduling problem, *Management science* 38, 1018-1033
- Wemmerlöv, U., 1979, Design factors in MRP systems: a limited survey, *Production and inventory management journal* 20, 4, 15-34
- Wemmerlöv, U., 1988, *Production planning and control procedures for cellular manufacturing*, American production and inventory control society, Falls Church, VA.
- Whybark, D.C., 1984, Production planning and control at Kumera Oy, *Production and inventory management journal* 25, 1, 71-82
- Wight, O., 1984, *Manufacturing resource planning: MRP II*, Oliver Wight Limited Publications Inc., Essex Junction, Vermont.
- Wijngaard, J., 1986, Productiebesturing anno 1986: op zoek naar de Steen der Wijzen (in Dutch), *Bedrijfskunde* 58, 4, 361-382
- Wildemann, H., 1992, *Die Modulare Fabrik, Kundennahe Produktion durch Fertigungssegmentierung* (in German), 3ed, GFMT, St Gallen.
- Wiley, P.C.T., Ang, C.L., 1980, Computer simulation of the effects of inter-cell workload transfer on the performance of GT systems, *MATADOR conference* 21, 559-567
- Williams, E.F., Tüfekci S., Akansel, M., 1997, O(m<sup>2</sup>) algorithms for the two and three subplot lot streaming problem, *Production and operations management* 6, 1, 74-96
- Wilson, R.H., 1934, A scientific routine for stock control, *Harvard business review* 13, 116-128
- Wortmann, J.C., Muntslag, D.R., Timmermans, P.J.M.(eds), 1997, *Customer-driven manufacturing*, Chapman & Hall, London.
- Yang, K.K., Jacobs, F.R., 1992, Comparison of make to-order job shops with different machine layouts and production control systems, *International journal of production research* 30, 6, 1269-1283
- Yeung, J.H.Y., Wong, W.C.K., Ma, L., 1998, Parameters affecting the effectiveness of MRP systems: a review, *International journal of production research* 36, 2, 313-331
- Zelenovic, D.M., Tesic, Z.M., 1988, Period batch control and group technology, *International journal of production research* 26, 4, 539-552



## AUTHOR INDEX

- Ahmadi, R.H., 159, 261  
 Aitchison, K., 17, 262  
 Akansel, M., 135, 267  
 Alford, H., 21, 261  
 Amelsvoort, P. van, 17, 210, 264  
 Ang, C.L., 22, 267  
 Babbage, C., 5, 261  
 Baker, K.R., 80, 246, 261, 265  
 Banerjee, S.K., 82, 261  
 Bauer, A., 82, 211, 212, 213, 261  
 Berry, W.L., 14, 52, 72, 82, 88, 159, 160, 164, 178, 241, 253, 266, 267  
 Bertrand, J.W.M., 82, 83, 205, 261  
 Boctor, F., 71, 265  
 Bond, T.C., 81, 261  
 Borgen, E., 47, 48, 261  
 Botter, C., 63, 261  
 Boucher, T.O., 119, 261  
 Bowden, R., 82, 261  
 Browne, J., 46, 82, 261  
 Browne, R.A., 119, 263  
 Buitenhuis, C.H., 7, 261  
 Burbidge, J.L., i, 13, 17, 22, 41, 42, 46, 49- 53, 57-65, 67, 68, 70, 83-88, 92--96, 99-103, 111, 114, 206, 261, 262  
 Carlier, J., 240, 262  
 Chapman, S.N., 72, 88, 159, 160, 164, 178, 241, 253, 266  
 Chevelier, P.B., 80, 267  
 Cho, F., 81, 266  
 Clarke, G., 119, 262  
 Conway, R.W., 8, 80, 262  
 Dale, B.G., 22, 215, 262  
 Desruelle, P., 211, 266  
 Duggan, J., 82, 261  
 Forrester, J.W., 7, 262  
 Fox, R.E., 81, 262  
 French, S., 80, 262  
 Gaalman, G.J.C., i, 44, 80, 193, 246, 264, 265  
 Gallagher, C.C., 56, 262  
 Gantt, H.L., 6, 262  
 Garza, O., 20, 262, 263  
 Gigli, R.J., 58, 263  
 Glass, C.A., 246, 263  
 Goldratt, E., 70, 81, 263  
 Goyal, S.K., 118, 119, 263  
 Graves, S.C., 142, 245, 263, 265  
 Greene, T.J., 215, 263  
 Gupta, J.N.D., 193, 246, 263, 265  
 Habich, M., 71, 213, 263  
 Hackman, J.R., 102, 263  
 Hall, R.W., 70, 81, 263  
 Ham, C.J. van, 64, 261, 263  
 Harhen, J., 82, 261  
 Harris, F.W., 5, 8, 263  
 Hill, T., 91, 263  
 Hoekstra, S., 49, 263  
 Huang, P.Y., 72, 159, 265  
 Hyer, N.L., 13, 68, 69, 263  
 Ivanov, E.K., 62, 263  
 Jacobs, F.R., 72, 88, 90, 159, 267  
 Jamshidi, H., 71, 119, 263  
 Johnson, S.M., 8, 175, 246, 263  
 Kaku, B.K., 72, 88, 119, 159, 160, 167, 264  
 Kanet, J.J., 52, 264  
 Kelley, J.E., 8, 264  
 King, B.E., 72, 264  
 Knight, W.A., 56, 262  
 Kostreva, M.M., 142, 245, 263  
 Krajewski, L.J., 72, 88, 119, 159, 160, 167, 264  
 Kropp, D.H., 245, 264  
 Kuipers, H., 17, 210, 264  
 Kusunoki, K., 81, 266  
 Land, M.J., i, 44, 264  
 Lee, T.-E., 159, 264  
 Leeuw, A.C.J. de, 6, 264  
 Loersch, A.G., 264  
 Luss, H., 71, 264  
 Lyons, G., 82, 261  
 Malhotra, M.K., 73, 88, 167, 181, 253, 266  
 Maxwell, W.L., 8, 80, 262  
 Megens, E., 223, 264

- Melby, O.H., 47, 48, 264  
Meredith, J.R., 63, 223, 266  
Miller, L.W., 8, 80, 262  
Miltenburg, J., 20, 81, 264  
Minieka, E., 255, 264  
Mitra, D., 81, 264  
Mitrani, I., 81, 264  
Mitranov, S.P., 62, 265  
Mitten, L.G., 246, 265  
Monden, Y., 81, 265  
Monhemius, W., 8, 64, 265  
Muckstadt, J.A., 71, 119, 245, 264, 265  
Muntslag, D.R., 83, 267  
Muth, J.F., 8, 265  
Nederend, W.G. van het, 7, 261  
New, C.C., 40, 64, 67, 68, 87, 88, 90, 95, 114, 265  
Olorunniwo, F.O., 17, 54, 56, 265  
Orlicky, J., 82, 265  
Ouenniche, J., 71, 265  
Partridge, J.T., 17, 262  
Petrov, V.A., 62, 63, 265  
Posner, M.E., 159, 264  
Potts, C.N., 246, 263, 265  
Preston White, K., 80, 265  
Pyke, D.D., 246, 261  
Rachamadugu, R., 71, 119, 265  
Rees, L.P., 72, 159, 265  
Riezebos, J., 80, 193, 246, 265  
Ritzman, L.P., 72, 264  
Rodammer, F.A., 80, 265  
Romme, J.H.M.H., 49, 263  
Roundy, R.O., 119, 245, 265  
Russell, D., 22, 215, 262  
Sadowski, R.P., 215, 263  
Satir, A.T., 118, 119, 263  
Scholl, A., 43, 265  
Schonberger, R.J., 72, 81, 266  
Senge, P., 56, 203, 266  
Shivnan, J., 82, 261  
Shtub, A., 71, 119, 266  
Sitter, L.U. de, 210, 266  
Slomp, J., 46, 88, 266  
Smunt, T.L., 20, 245, 262, 263, 264  
Sridharan, V., 52, 266  
Steele, D.C., 44, 72, 73, 87, 88, 95, 159, 160, 164, 167, 178, 181, 241, 253, 266  
Steudel, H.J., 211, 266  
Stokking, E.J., 167, 266  
Sugimori, Y., 81, 266  
Suresh, N.C., i, 63, 68, 90, 223, 266  
Susman, G.I., 20, 26, 97, 200, 202, 210, 266  
Szendrovits, A.Z., 150, 245, 246, 266  
Takkenberg, C.A.Th., 212, 266  
Taylor, B.W., 72, 159, 265  
Taylor, F.W., 5, 266  
Testic, Z.M., 86, 267  
Thompson, G.L., 8, 265  
Thompson, J.D., 18, 19, 20, 26, 267  
Timmermans, P.J.M., 83, 267  
Trietsch, D., 246, 267  
Tu, Q., 71, 119, 265  
Tüfeki, S., 135, 267  
Uchikawa, S., 81, 266  
Udo, G., 54, 56, 265  
Vakharia, A.J., 20, 267  
Vollmann, T.E., 14, 82, 267  
Wagner, H.M., 119, 267  
Wakker, A.M. van de, 44, 206, 267  
Walker, M.R., 8, 264  
Wein, L.M., 80, 267  
Wemmerlöv, U., 13, 20, 68-70, 72, 263, 267  
Whitin, T.M., 119, 267  
Whybark, D.C., 14, 47, 48, 69, 82, 90, 267  
Wight, O., 71, 82, 267  
Wijngaard, J., i, 72, 81-83, 205, 261, 264, 267  
Wildemann, H., 17, 267  
Willey, P.C.T., 22, 267  
Williams, E.F., 135, 267  
Wong, D.S., 72, 264  
Wortmann, J.C., 82, 83, 205, 261, 267  
Wright, J.W., 119, 262  
Wurgaft, H., 159, 261  
Yang, K.K., 72, 88, 90, 159, 267  
Yeung, J.H.Y., 52, 267  
Zelenovic, D.M., 86, 88, 267  
Zhang, W., 20, 264

---

## Summary

This study aimed at gaining insight into the main factors that have to be taken into account when designing a planning system for the co-ordination between cells in a cellular manufacturing system. In the last decades, the application of cellular manufacturing systems has become increasingly popular, both in production and service industries. The concept is known under various names: team based production, semi-autonomous groups, group technology, and so on. A change towards cellular manufacturing has important consequences for both the design and organization of the production system (lay-out, technology, and the allocation of tasks, responsibility and authority with respect to the transformation process in the system). However, the transformation process has to be planned and controlled in order to obtain the logistical benefits of a change towards cellular manufacturing. In this study, we investigate the consequences of applying cellular manufacturing for the design of a planning system.

Planning systems are responsible for regulating, co-ordinating, and monitoring the flow of work through the production system. In the past, various developments, internal to the firm as well as external to it, have led to changes in these systems. In Chapter One we described the origins of these developments and outlined eight different factors (e.g., changes in the labour market, demand market, available production technology, information systems, planning theory, and so on). The various origins of these changes led us to expect that the change towards cellular manufacturing would have consequences for planning systems as well. The first research question of this study focused on cell co-ordination characteristics. We focussed on multi-stage cellular manufacturing systems, as these systems will have interrelationships between cells.

In order to be able to examine the consequences for planning systems, we chose to restrict our attention to a well-defined planning system that has been proposed and criticized for its suitability for co-ordinating multi-stage cellular manufacturing systems. This is the *basic unicycle Period Batch Control* (PBC) system. The second research question of this thesis concerned the identification of the main factors that distinguish the basic unicycle Period Batch Control system from other planning concepts in providing support for the co-ordination requirements between cells.

The third research question examined the design choices in the basic unicycle PBC system and the relationship to production system design in greater depth. It was interested in the main choices that should be made when designing such a PBC system and the effect of these design choices on system performance.

We performed five case studies in small-batch metal ware production situations. All firms used a multi-stage cellular manufacturing system in their production of parts, although none used the type of PBC system that we examine in this thesis. We identified the relationships

between the cells and the co-ordination mechanisms that were applied in order to cope with the corresponding co-ordination requirements. We made a distinction between three types of relationships between cells: sequential, simultaneous, and latent relationships. The occurrence of sequential and simultaneous types of relationships can actually be observed. Identification of latent relationships can provide insight into alternative arrangements of the other types of relationships between the cells. This may help to improve system performance.

The essential characteristics of the basic unicycle PBC system that we examined are that it is single cycle, single phase, and uses a single offset time for all work orders. This results in a transparent system with an intermittent but predictable goods flow. The periodic nature of the PBC system enables the cells to perform their own detailed planning, while the overall co-ordination of the flows in the system is being performed by the PBC system.

The effectiveness of such a PBC system depends on a number of design choices. We have identified the length of the period  $P$ , the number of stages  $N$ , the throughput time  $T=N \cdot P$ , the definition of the work orders (contents of the stages), and the batching policy (applying overlapping production between successive operations) as the main design choices in a PBC system. These choices depend on the congruity between the production system structure and the planning system. We provided a mixed integer programming model to support decisions about stage contents and a framework that helps to set suitable stage decoupling points.

Literature on PBC system design does not provide clear support for determining appropriate values for these parameters. In order to be able to measure the effect of these design choices, we mathematically modelled the factors that are important in determining the period length  $P$  and a suitable batching strategy. Heuristic solution approaches were developed that provide support in finding an initial configuration of a PBC system. The characteristics of the production system are partially taken into account in these solution approaches.

We developed a simulation modelling approach in order to determine the effect of various configurations of the PBC system on system performance. Literature had shown that these choices do have an effect on the manufacturing throughput time. Our study investigated whether there would be a significant effect if this manufacturing throughput time remained constant. Our simulation used the data structure of a cellular manufacturing system described in literature, which enabled us to perform some validity checks. The simulation analysis revealed that the main factors that should be taken into account in designing a PBC system are the length of the period, number of stages, and the batching strategy. Even if the total throughput time did not change we found that varying the number of stages and the period length, especially on dependability and costs, had a considerable effect.

Designers of planning systems should consider the effect of these design choices on the logistical performance of systems. We have provided a design procedure aimed at improving the congruity between production system design and planning system design. Our approach enables an explicit trade-off between the various design choices to be made.

---

## Samenvatting

Deze studie was gericht op het verkrijgen van inzicht over de belangrijkste factoren die in beschouwing genomen moeten worden bij het ontwerp van een planningssysteem voor de coördinatie tussen cellen in een groepsgewijs producerend systeem. In de laatste decennia is de populariteit van toepassing van dergelijke groepsgewijze productiesystemen gegroeid, zowel in productie als in dienstverlenende organisaties. Het concept is bekend onder verschillende namen, zoals team-georiënteerde productie, semi-autonome groepen, groepen technologie, enzovoorts. De overgang naar groepsgewijze productie heeft belangrijke consequenties voor zowel het ontwerp als de organisatie van het productiesysteem (lay-out, technologie, en de verdeling van taken, bevoegdheden en verantwoordelijkheden met betrekking tot het transformatieproces). Het transformatieproces dient echter ook te worden gepland en beheerst om de logistieke voordelen van groepsgewijze productie te kunnen verwezenlijken. In deze studie vragen we ons af welke consequenties de toepassing van groepsgewijze productie zou moeten hebben voor het ontwerp van een planningssysteem.

Het planningssysteem is verantwoordelijk voor het reguleren, coördineren, en bewaken van de voortgang van het werk door het productiesysteem. In het verleden zijn veranderingen in deze systemen geïnitieerd vanuit diverse ontwikkelingen, afkomstig zowel van binnen als buiten het bedrijf. In hoofdstuk een beschreven we de oorsprong van deze ontwikkelingen en maakten onderscheid tussen acht verschillende invalshoeken. We onderscheidde veranderingen in arbeidsmarkt, consumentenmarkt, beschikbare productietechnologie, informatiesystemen, planning theorie, enzovoorts. De diversiteit in oorsprong van de historische ontwikkelingen in planningssystemen wekte de verwachting dat een verandering richting groepsgewijze productie eveneens consequenties zou hebben voor het planningssysteem.

De eerste onderzoeksvraag richtte zich op kenmerken van de coördinatie tussen cellen in zogenaamde meerfasige groepsgewijze productiesystemen, waarin cellen onderling gerelateerd zijn binnen het transformatieproces.

Om de consequenties van een overgang naar groepsgewijze productie voor het planningssysteem te kunnen bestuderen hebben we onze aandacht gericht op een goed gedefinieerd planningssysteem dat zowel is aanbevolen als bekritiseerd voor zijn geschiktheid om een dergelijk productiesysteem te coördineren. Dit is het *basis een-cyclische PBC systeem* (een periodiek batch-besturingssysteem). De tweede onderzoeksvraag van deze studie betrof de identificatie van de belangrijkste factoren waarin genoemd systeem zich onderscheidt van andere planningconcepten in het ondersteunen van de coördinatiebehoeften tussen cellen.

De derde onderzoeksvraag bestudeerde ontwerpkeuzes in het basis een-cyclische PBC systeem en de relatie met het ontwerp van het productiesysteem. We waren geïnteresseerd in de belangrijkste keuzes die gemaakt moeten worden bij het ontwerp van zo'n planningssysteem en het effect van deze keuzes op de prestaties van het gehele systeem.

Er zijn door ons vijf casestudies uitgevoerd in kleinserie metaalbewerkende productiebedrijven. Al deze bedrijven maakten gebruik van een meerfasig groepsgewijs producerend systeem in hun onderdelenproductie, hoewel geen van hen gebruik maakte van het type PBC systeem waarnaar onze aandacht in het bijzonder uitgaat. Wij hebben de relaties tussen de cellen onderzocht en de coördinatie mechanismen die men toepaste om tegemoet te komen aan de corresponderende coördinatiebehoeften. Er werden door ons drie typen van relaties tussen cellen onderscheiden: sequentiële, simultane en latente relaties. Door observatie kunnen sequentiële en simultane relaties worden geïdentificeerd. Het onderkennen van latente relaties kan inzicht opleveren over alternatieve ordeningen van de andere typen relaties tussen cellen. Dit kan helpen om de prestaties van het systeem te verbeteren.

De essentiële kenmerken van het door ons bestudeerde basis een-cyclische PBC systeem zijn het hanteren van éénzelfde cyclus voor alle producten en onderdelen, één identiek moment voor het vrijgeven van werk naar het productiesysteem, en één interne doorlooptijd voor alle werkopdrachten die worden vrijgegeven. Dit resulteert in een transparant systeem met een intermitterende maar voorspelbare goederenstroom. Het periodieke karakter van het PBC systeem maakt het voor de cellen mogelijk hun eigen detail planning uit te voeren, terwijl de overkoepelende coördinatie van de stromen in het productieproces door PBC wordt verzorgd.

De effectiviteit van zo'n PBC systeem hangt af van een aantal ontwerpkeuzes, waarvan de belangrijkste zijn: de lengte van de periode  $P$ , het aantal productiefasen  $N$ , de productiedoorlooptijd  $T=N \cdot P$ , de samenstelling of definitie van werkopdrachten (inhoud van de productiefasen) en het beleid met betrekking tot het splitsen van series. Deze ontwerpkeuzes zijn afhankelijk van de samenhang tussen de structuur van het productiesysteem en het planningssysteem. Een door ons ontwikkeld wiskundig optimaliseringsmodel kan gebruikt worden bij het bepalen van de werkopdrachten. Daarnaast hebben wij een raamwerk ontwikkeld waarmee gewenste ontkoppelingen tussen productiefasen kunnen worden bepaald.

Literatuur over het ontwerp van PBC systemen geeft weinig ondersteuning bij het bepalen van geschikte waarden voor de ontwerpparameters. Wij hebben een wiskundig model ontwikkeld waarmee de factoren die een rol spelen bij het bepalen van de periodelengte  $P$  en de strategie om series te splitsen expliciet gemaakt worden. Dit helpt bij het zichtbaar maken van het effect van deze parameters op de prestaties van het systeem. Door ons zijn methoden ontwikkeld waarmee de optimale oplossing van dit model benaderd kan worden. Deze methoden kunnen ingezet worden om een initiële configuratie van het PBC systeem te bepalen. Karakteristieken van het productiesysteem worden in deze benaderingsalgoritmen op een beperkte wijze meegenomen.

Om het effect van verschillende PBC configuraties op de prestaties van het systeem te kunnen bepalen hebben we een simulatiemodel ontwikkeld. Vanuit de literatuur is bekend dat de ontwerpkeuzes invloed hebben op de productiedoorlooptijd. Wij onderzochten of er nog steeds sprake is van een significant effect van verschillende ontwerpkeuzes als deze productiedoorlooptijd constant zou blijven. In de simulatie maakten we gebruik van een in de

literatuur beschreven gegevensstructuur van een groepsgewijs productiesysteem. Dat maakte het mogelijk om de validiteit van de uitkomsten te controleren. De simulatie analyse heeft duidelijk gemaakt dat de belangrijkste ontwerpkeuzes voor een PBC systeem zijn: de lengte van de periode, het aantal productiefasen, en de strategie met betrekking tot het splitsen van series. Zelfs als de productiedoorlooptijd constant blijft heeft het variëren van deze parameters een significant effect op de prestaties van het systeem, met name wat betreft leverbetrouwbaarheid en kosten.

Ontwerpers van planningssystemen dienen rekening te houden met de effecten van deze ontwerpkeuzes op de logistieke prestaties van het systeem. Te vaak worden deze keuzes gebaseerd op kenmerken van het oude productiesysteem, zonder de veranderingen die gepaard gaan met een overgang naar groepsgewijze productie in beschouwing te nemen. Onze ontwerpprocedure maakt het mogelijk de samenhang tussen het ontwerp van productiesysteem en planningssysteem te verbeteren. Daarmee wordt een expliciete afweging mogelijk tussen de diverse ontwerpkeuzes die moeten worden gemaakt.