

Knowledge Agents Represented by Knowledge Functions

Presented in written form to the
annual Meeting of the German Physical Society,
Physics of Socio-Economic Systems
Regensburg, 11 March 2004

Contents:

Abstract.....	2
Introduction: Information and Knowledge	2
Operable Knowledge	2
External Relations of Knowledge Functions	3
Establishing Knowledge Functions in Companies.....	4
Competence and Rationalisation Potential in Companies	6
Validation of the Method in Companies	6
Knowledge and Alternativity	8
Entropy and Knowledge.....	11
Money Added Value.....	12
Agents Concepts and Knowledge Functions	14
References	17
Curriculum Vitae	Fehler! Textma

Vers. 2.2.3

H.-D. Kreft
VisionPatents AG
D-21521 Dassendorf
Fax: +49 (0)89 1488 294 946
dkreft@visionpatents.com

ABSTRACT

ABSTRACT

The discovery of operable knowledge features has during the last two years shown that many economic features are explainable by mathematical methods. It is analysed how this discovery can also contribute to the concept of economic agents. The fundamental frame for agent concepts is set by physical conditions, which are explained. It is shown how within this frame operable knowledge can act in a way that new economic features appear.

INTRODUCTION: INFORMATION AND KNOWLEDGE

We start with some fundamental aspects between information and knowledge.

Information is characterised by its facticity. Knowledge is characterised by its modality. This difference is demonstrated by **Figure 1**. At the left side are presented some physical facts like ink dots on paper which we may interpret as a window. By further interpretation there should be near to the window a strong air movement from right to left. At the outer side of the window it seems to rain. At least there should be in the room two opened doors, otherwise there must be an other reason for the move of the air in a closed room. We see that only the facts of the ink on the paper are real in a physical sense, the interpretations are modal. It is possible that there is an air movement in the room, possibly there are two doors etc. The physical facts of the dots can only present relations between themselves. Knowledge in contrast is able to add modality (possible facts) to the real physical facts. The air movement is assumed it is not real in a physical sense.

We can summarise that carriers of information are physical facts. So information is present in the form of physical facts like dots on paper or electromagnetic waves. In contrast knowledge is present in the form of a potential which can produce information additional to facts. That we will explain in detail.

Operable Knowledge

In the following are introduced mathematical constructs which explain specific features of knowledge. Therefore we speak of operable knowledge features and in short of operable knowledge. The theory behind is named humatics. This word is composed of the two word humanism and mathematics, since human features are explained mathematically. With this discovery of operable features knowledge becomes like information a tool of interdisciplinary use. So, this features are independent of the specific meaning or use of the word knowledge.

There is known a pragmatic and an axiomatic approach for explaining operable knowledge. Both ways are presented (see Figure 2, page 4). At least both concepts are mathematically equivalent. We start with the pragmatic approach in the chapter

"External Relations of Knowledge Functions", page 3. This pragmatic approach introduces firstly knowledge functions and explains how they fit together and in which way that explains operable knowledge features. The principle is shown in the left side of Figure 2, page 4. There are shown two function A, B which are harmonised in a way that their extremes are compensated. We see that the outer (external) appearances of this functions are important. So this approach deals with the outer interactions and interrelations between knowledge functions. Harmonisation and competence of knowledge appear as such external relations. This method lead directly to some results in companies. For example we can determine a quantifiable limit for rationalisation beyond which a company cannot go if it wishes to retain its competence.

In the chapter "Knowledge and Alternativity", page 8, is introduced the axiomatic approach. This method needs a strong mathematical physical analyse of the concept of information and its mathematical extension. The principles are shown in Figure 2, page 4. In the right upper part is presented a physical alternative presented by the both sides A, E of a coin. Below is shown a modal alternative. A piece of paper is in the one situation present in the lower position A and in an other at the higher position E. Only knowledge is able to see the alternative position E. This position is not real in the sense that the paper will not be caused only by physical laws to change its lower position A into that of E.

We show that both approaches will produce the same mathematical outcome.

In the chapter "Agents Concepts and Knowledge Functions", page 14, we give some advices how to apply the concepts of knowledge functions on economic agents concepts.

EXTERNAL RELATIONS OF KNOWLEDGE FUNCTIONS

We make two initial assumptions with regard to the operability of knowledge:

1. In market economies human skills and/or abilities are goods which can be evaluated by supply and demand.
2. Operable knowledge features can be represented by mathematical functions.

Since the values of human skills or abilities are determined by supply and demand, they depends on an external interaction between an individual and its social environment. In the following chapter we explain how this relations are reflected by knowledge functions. A very important feature of knowledge is its ability to innovate that means to create new knowledge. We will see, that knowledge functions present an "inner" structure which leads to innovation. This is explained in the chapter "Knowledge and Alternativity", page 8.

At least we will see that the external relations of knowledge functions are related to its informal outcome, since its "inner" structure is related to innovation

Establishing Knowledge Functions in Companies

In Figure 3, page 4 is shown how to each employee in a company is assigned her specific knowledge function. In Figure 5, Figure 6, page 5 is shown how knowledge functions can be used without showing the relation to an individual employee. All the interrelations between different knowledge functions are independent from the persons behind. What we mean by interrelations between knowledge functions and how it is represented in economic reality is explained by use of Figure 3, page 4. there we see the principal elements of a specific type of knowledge function the so called Q-Distributions.

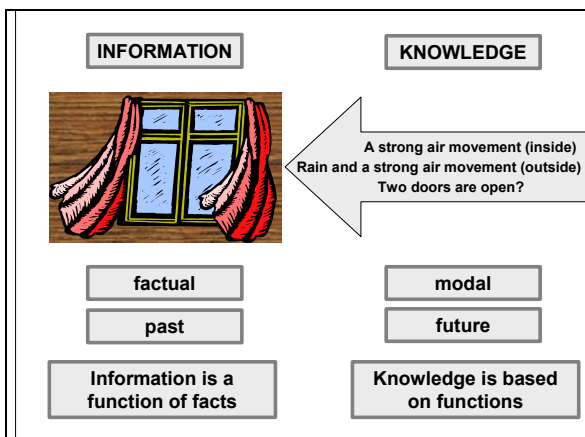

Figure 1: Information and knowledge

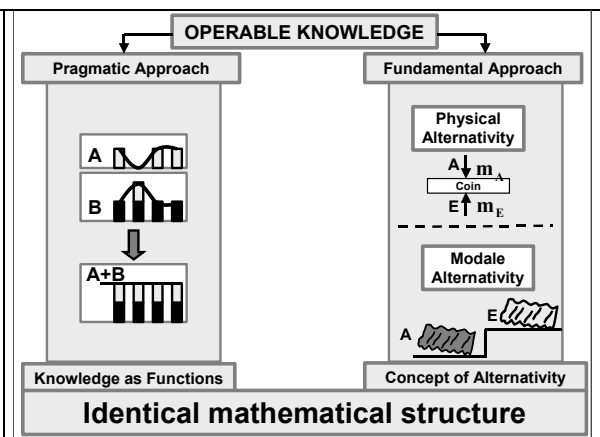

Figure 2: Approaches to operable knowledge

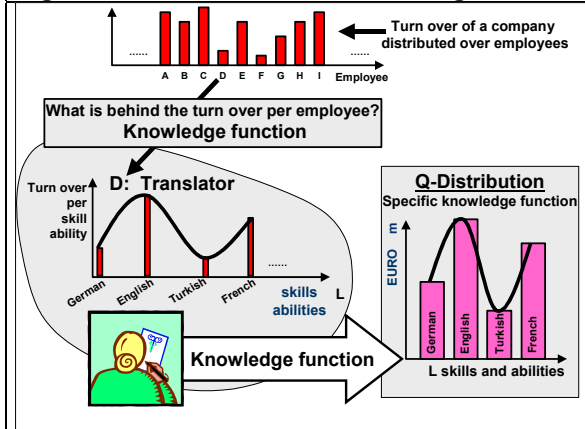

Figure 3: Establishing of real knowledge functions

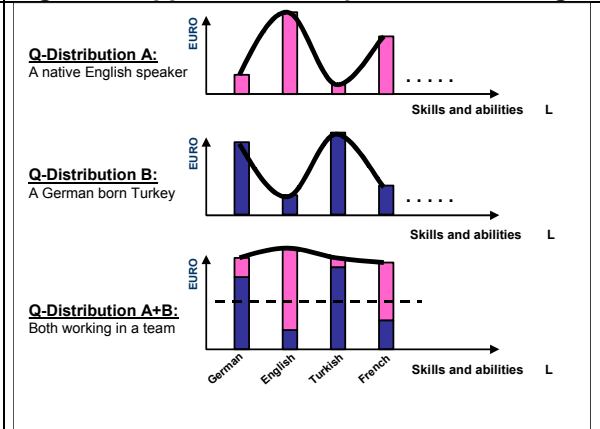

Figure 4: Harmonisation of knowledge functions

In the top of Figure 3 is given a bar chart which shows the distribution of the turn over of a company on the employees (numbered here A to I). There exists a second distribution, the Q-Distribution (lower part of Figure 3) which shows how the skills and abilities of an employee (a translator D with knowledge in German, English, Turkish, French) contributes to his part of the turnover. These skills and abilities which appear in a knowledge function on the x-axis are named the constituents. On the y-axis of a Q-Distribution is given a money value (e. g. in the currency € or US\$). This money value defines the economic value of a constituent (that is a specific skill or ability) represented by a position at the x-axis. All knowledge features which we can analyse with Q-Distributions are named "operable knowledge features" or in short "operable knowledge".

We can summarize: Q-Distributions distribute the per head turnover of an employee onto the skills and abilities which enable the employee to fulfil her job and to contribute thereby to the future success of a company. It is this contribution which enables companies to survive in market competition.

For showing how Q-Distribution describe real appearances of knowledge we start in Figure 4 with the Q-Distributions of two persons A, B. The person A is a native English speaker who is educated in German language and better in French. The person B is a German born son of Turkish parents who speaks his mother language in his family but has passed through some German schools. Their daily work is to handle jointly financial transactions of German, English, Turkish and French clients. So, their knowledge functions are added (harmonised), the result is given in the lower Q-Distribution A+B. We can derive two results (more results appear by use of mathematical methods) from the situation shown in Figure 4: Obviously we can see that the combined knowledge function in Figure 4 is more homogenous than the separated ones. That means for the situation in real life: The outer appearance of the language abilities of the team is more continuous than their individual appearance is. For example: If one from the outside is calling to the team he will be transmitted to the person who is nearer to the callers language requirement than a single person of the team will be. This visible effect is also quantifiable by applying mathematical methods on the used knowledge functions.

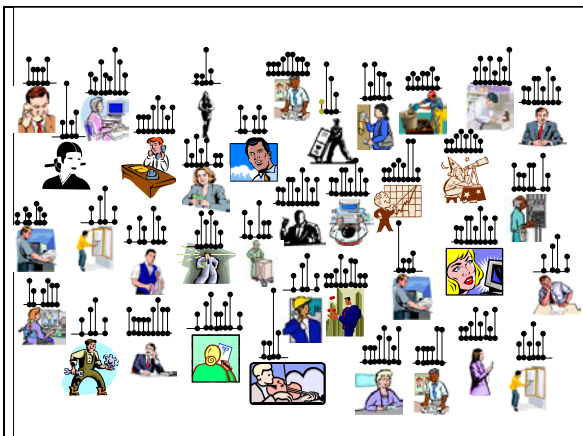

Figure 5: Knowledge functions of employees

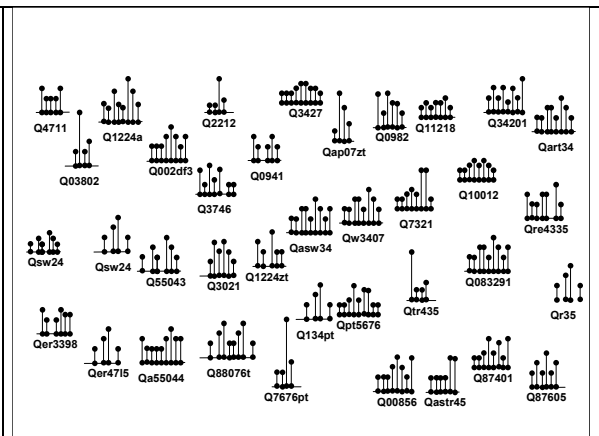

Figure 6: Anonymous knowledge functions

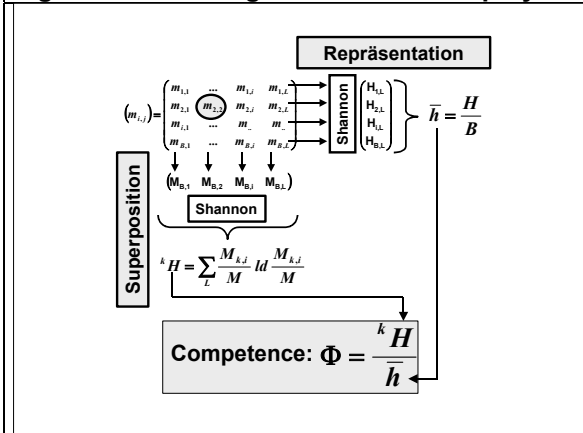

Figure 7: Emergence of competence

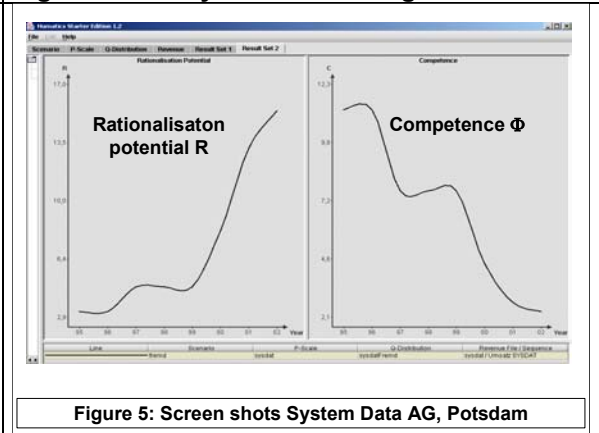

Figure 8: Results of a pilot

When we need a quantifiable value for volumes of knowledge, mathematics comes to our aid in the form of the Shannon Formula. This formula already plays a prominent role in two areas of science. On the one hand it appears as the Boltzmann-

Planck formula for the determination of entropy. On the other hand the formula is used in computer science as the Shannon formula to determine volumes of information in bits or bytes. How to apply the Shannon Formula on Q-Distributions is explained in detail in the chapter "Knowledge and Alternativity", page 8. We measure the result of this application in the unit [hbit], which is the shortened form of "human bit" and name it the human potential H. We can summarise here: If the outer appearance is more even H becomes larger and otherwise it decreases.

Competence and Rationalisation Potential in Companies

We define economic competence as that set of skills and abilities which enable a company to compete successfully in the market. We will show how competence follows from operable knowledge features.

In Figure 7, page 5 we assemble in the matrix different knowledge functions, for example all the Q-Distributions of the employees of a company or department. On this matrix we apply two mathematical methods which we name here "super positioning" and "average representation". In the lower left part of Figure 7 is symbolised how the two Q-Distributions A, B are super positioned (which is simply adding their constituents). Super positioning indicates very strongly the appearance of a new constituent as it is shown by the encircled constituent. The result of the application of the Shannon formula on a super positioned Q-Distribution is symbolised by kH . For the method of "average representation" we determine firstly the H-Values of each knowledge function in the matrix (that is, each row) and divide the sum by the number of rows and get the value h. In this case the contribution of the one encircled constituent $m_{i,j}$ is also divided and thereby decreased. We divide now kH by h and get the value Φ which is a measure of competency. This becomes intuitively understandable if we assume that in a first step we apply the method in the case where the encircled $m_{i,j}$ is not in the matrix. If in the second step the new constituent $m_{i,j}$ is also considered, this represents the case where, for example, one employee has learned a new skill. In this case the superposition immediately will register this, and the counter kH of the quotient increases, whereas the quotient Φ increases. This increase in Φ indicates a higher competence which is represented by the additional constituent. It should only be mentioned that a deeper analysis shows: the lower the competence the higher is the "rationalisation potential", since rationalisation potential indicates how often the same constituents are available. So operable knowledge features present a quantifiable limit for rationalisation beyond which a company cannot go if it wishes to retain its set of competences.

Validation of the Method in Companies

Between September 2001 and February 2002 the Land Brandenburg (one of the 15 German counties) set up a first pilot project for the measurement of operable knowledge features in a company with 220 employees (System Data AG, Potsdam). The methods were applied over a period (1995 – 2002) for which all the

company's control systems data was known. The question was: Would the methods of operable knowledge show details which the management did not know at the time but which they were able to corroborate later? The test was completely positive and smaller tests (in banking service centres) have led to similar results. One result was the determination of competence and rationalisation potential which are shown in the screen shot of Figure 8, page 5. The figure is the result of the practical test of the first version of the so called Humatics-Kernel-Software (HKS). All the mathematics as described above was performed by this software. The software enables us to determine such operable knowledge features as human potential H , competence Φ , innovation ∇ (Nabla), economic temperature T . The charts of Figure 8 show, for the period 1995 to 2002, the development of competence (right hand chart) and the development of rationalisation potential (left hand chart). First, the methods of operable knowledge which we have described were used to indicate a drastic decrease of competence shown in Figure 8. The management has confirmed this finding. The reason for the decrease in competence is that during that period the company developed through a strong expansion phase, because there was strong market demand for the services of the company. The company reacted by taking on new employees which mostly had identical skills and abilities. From our above analysis it is clear that this reduces the measure of competence and at the same time increases the rationalisation potential. The "saddle" in the right hand chart between 1997 and 1999 indicates a real stabilisation of competence in that period. The company during that time took on employees with new skills and abilities, which had mostly not been present in the company before that time. This "saddle" result was also confirmed by the management.

The results of this pilot have shown that for too long the company relied on its old knowledge base. They did not use their earlier good financial situation to train (or recruit) workers in order to develop a stable knowledge base. The company reacted after 2002 by large-scale dismissals of employees.

KNOWLEDGE AND ALTERNATIVITY

In the following we introduce the fundamental mathematical approach based on the concept of alternativity as it is shown in the right side of Figure 2, page.

Firstly we explain the fundamental concept of the measure of information and secondly we extend it for discovering operable knowledge features. Because this extension is based on mathematical methods it follows that operable knowledge features are independent of different meanings and uses of the word knowledge.

We start with Claude E. Shannon (Shannon, 1948) who discovered between 1945 and 1947 on the basis of the early work of Hartley a measure of information in the unit "bit". For determining an amount of information by that unit we count the appearances of facts (states) in the form of frequency diagrams and apply the Shannon formula on it. Thereby this "Shannon information" presents relations between distinguishable facts (states). That is symbolised in the lower left part of Figure 9, page 10.

In his article Shannon (1948) presented a famous curve (see right side Figure 9). He wrote: "*The entropy in the case of two possibilities p and $q = 1 - p$, namely is plotted in Fig. 7 as a function of p .*"

$$H = -(p \log p + q \log q)$$

Formula 1: Shannon formula for Shannon's curve

This curve is mostly considered as the result of the complete possible spectrum of frequency diagrams which physically different coins may produce (see left upper side of Figure 9). It will be difficult to find in reality a complete set of such coins. So, for showing the real existence of that curve we manipulate coins in a way they present the needed frequency diagrams. That means we manipulate the world in relation to the outcome of a function. This ability of knowledge to form the world in relation to the results of functions is substantial for the following analysis. Therefore we identify functions as the specific carriers of knowledge from which knowledge produces outcomes (like set numbers). We define: knowledge uses functions for generating facts. In this sense a coin is a fact that fits the requirement of a function set by knowledge. For showing the wide ranging implications of the definition we can put this briefly: a car is the result of a combination of energy and material following a specific input/output function (which is given by knowledge). We can also identify any assembling of different things in a group (flowers in a bouquet) as facts which are the outcomes of knowledge functions.

It is obvious that our method of manipulating coins is not in accordance with the axioms of statistical methods. The probabilities p , q of the events are not independent, since we manipulate the coins the alternativity relation ($p + q = 1$) is given ex ante. In statistics it is one of the fundamental points that frequency diagrams are known only ex post, after we have measured (counted) the occurrence of the facts. Also the adding of the information values $p \log p$ and $q \log q$ in the Shannon for-

mula needs in statistics the independency of the underlying events of the probabilities p, q . Since the knowledge produced by the famous Shannon curve is as real and identical in its outcome as it is appropriate to the statistical axioms, we need a new mathematical concept which fulfils the requirements of both methods. Which shows how alternativity ($p + q = 1$), coincidence $p \cdot q$ and at least the Shannon curve are in accordance with the setting of knowledge. If we have found this concept it presents some fundamental features of knowledge which we name operable knowledge features.

The fundamental idea here is to combine in a mathematical structure outcomes of physical reality with that of knowledge. So, we are looking for a structure of two numbers. Examples of such a structure are complex numbers.

$$\begin{aligned}
 1: \quad & \underline{m} = m_A + i m_E \quad m_A, m_E \in \{+R\} \\
 2: \quad & m = m_A + m_E \quad ; \quad m = [\underline{m}] \\
 3: \quad & 1 = \lambda_A + \lambda_E \quad ; \quad \lambda_A = \frac{m_A}{m} \quad ; \quad \lambda_E = \frac{m_E}{m} \\
 4: \quad & \underline{\lambda} = \lambda_A + i \lambda_E \quad ; \quad \underline{m} = m \underline{\lambda} \\
 5: \quad & H = -(\lambda_A \text{ld } \lambda_A + \lambda_E \text{ld } \lambda_E) \quad ; \quad \lambda_E = 1 - \lambda_A \\
 6: \quad & H = -(p \text{ld } p + q \text{ld } q) \quad ; \quad q = 1 - p \\
 7: \quad & \underline{\lambda}^\# = \lambda_E + i \lambda_A = i \underline{\lambda}^* \quad \Rightarrow \quad \underline{\lambda} \underline{\lambda}^\# = i \underline{\lambda} \underline{\lambda}^* \\
 8: \quad & 1^2 = (\lambda_A + \lambda_E)^2 = \underline{\lambda} \underline{\lambda}^* + 2\lambda_A \lambda_E \Leftrightarrow \lambda_A \lambda_E = \frac{1 - \underline{\lambda} \underline{\lambda}^*}{2} \\
 9: \quad & T = \frac{M}{H} \quad ; \quad \text{with } M = m
 \end{aligned}$$

Formula 2: Definition of complex alternatives

Firstly we define a specific type of complex numbers \underline{m} , named complex alternatives (indicated by an underscore, see line 1 of Formula 2) in which both parts m_A, m_E (which are always positive real numbers) are related to each other by the condition of line 2. The simple steps in line 3 and 8 lead to the Shannon formula in line 6 whereby the curve in Figure 9 is given. Line 3 shows that complex alternatives contain by themselves alternativity ($\lambda_A + \lambda_E = 1$) and simultaneously they contain the feature of coincidence: $\lambda_A \cdot \lambda_E$ (line 8). So, all the above mentioned conditions are fulfilled. Since there are infinite possibilities to choose different m_A, m_E for forming the sum $m = m_A + m_E$ there is an infinite set of complex alternatives which are defined by one single real number (the basic real number m). For example we can write (in relation to the symbol definition in line 2) for the real number $m = 4 = [4] = [2 + 2i] = [0.5 + 3.5i] = 4 \cdot [\cos^2 \varphi + i \sin^2 \varphi] = 4 [0.5 + 0.5i]$ etc. Since there is between a real number and its infinite set of complex alternatives a defined relation, these set (or subset) represents an outcome of the function $[4]$. We name m_A the applicative number of \underline{m} and define it as a result of a measure or count of distinguishable (physical) facts in general. We name the number m_E as the interpretative number of \underline{m} which is set by knowledge. From lines 3, 4 we see that to each complex alternative is assigned a complex alternative norm $\underline{\lambda}$ from which we determine the Shannon information H in line 5. We can interpret any complex alternative as a

frequency distribution of two bars of the high m_A, m_E . So any real m represents by its complex alternatives the infinite set of all such possible frequency diagrams.

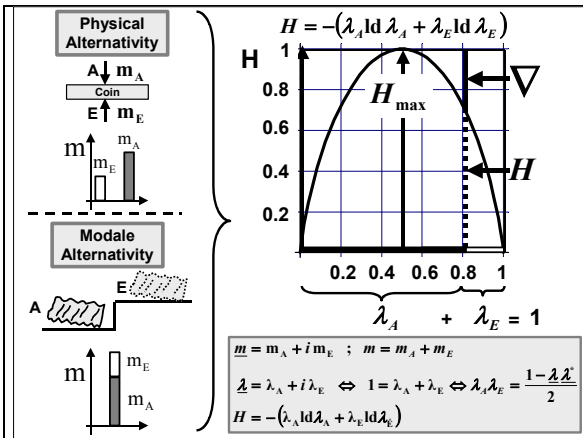

Figure 9: Shannon curve

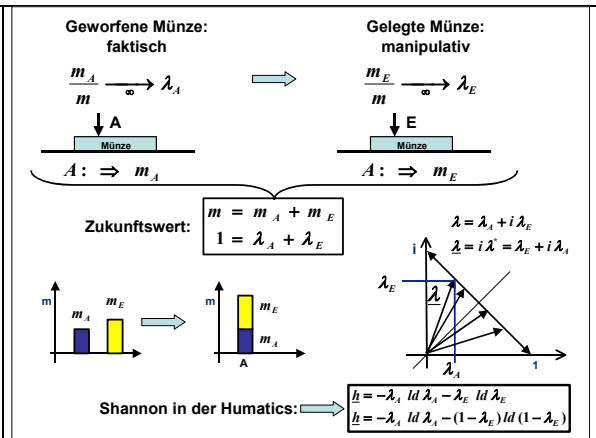

Figure 10: Q-Distributions

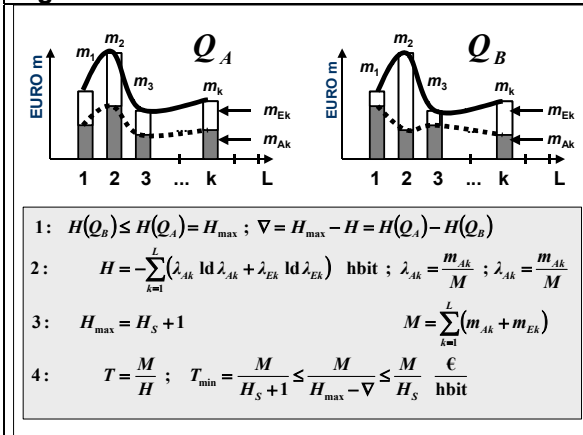

Figure 11: Inner variation of knowledge functions

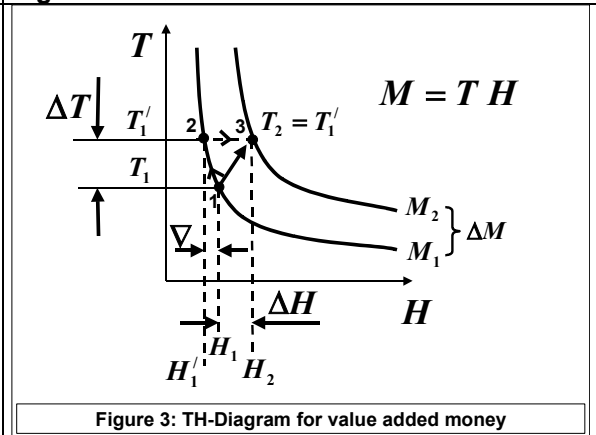

Figure 12: Money added value and innovation

After this formal introduction we demonstrate for a thrown coin that the use of complex alternatives is identical to the use of frequency diagrams. Let us assume we use a coin manipulated by knowledge. We decide to test the coin by 130 throws and have set thereby our basic real to $m = 130$. We know there exists the infinite set of $[130]$ complex alternatives, which represent the complete set of the possible outcomes of any test. So, knowledge is not presented in terms of a specific realisation but in terms of its complete function, given here by the uncountable set of complex alternatives. In this sense knowledge is a potential as it contains more possibilities than we can show in reality. That is necessary if knowledge shall be able to change the world in a way which is not determined by its given facts. We try now to find by measure that specific complex alternative which is related to the manipulated coin. Firstly we define what the "upper side" should be, that means we apply the number 1 to a real distinguishable appearance of reality (the one side of a coin). After a first throw the coin may present its "upper" side. We write therefore the complex alternative $(1 + 0i)$, whereby $m_A = 1$ is the applicative number, which indicates the appearance of the "upper side". The second throw shows not the "upper side", consequently we interpret that the "upper side" appears in its alternative state and write $(0 + 1i)$. After 130 throws we add the 130 found complex alternatives and may get $(50 + 80i)$ which indicates we have found the "upper side" in 50 cases. The result we can write also in the form $130 \cdot (5/13 + 8/13 i)$ (see line 4). If we apply the Shannon formula (row 4 of Formula 2) on the alternative norm $(5/13 + 8/13 i)$ we

get exactly a point on the Shannon curve (Figure 9), for example: $H = - (5/13 \cdot \log_2 5/13 + 8/13 \cdot \log_2 8/13)$. So, as this result is identical to a parallel measured frequency diagram, which has been established without use of complex alternatives, there is no conflict between usual statistical methods and complex alternatives.

In If we get an alternative norm of $(1/2 + 1/2i)$ knowledge has found a real distinguishable appearance which occurs to an other appearance alternatively. We speak of an identity, since both appearances occur identical like the both sides of an ideal coin appear. The Shannon formula presents for this case its maximum: $H_{max} = 1$. It is of importance that this identity – and we suppose identity in general - is not an effect of physical nature since it is impossible to find an ideal coin or an apparatus which presents it. Identity is a specific state of a knowledge function, is a feature knowledge can deal with. For example for the test of our coin we have used identity in our first step for identifying an "upper side".

In the following example we show how complex alternatives extend the frame of usual statistical methods. We construct a "black scale" with an ascending order of 100 points for indicating different appearances of black. Therefore we divide each part of our scale into 100 small squares which can be alternatively white or black. The possible combinations of mA black and mE white squares cover 100 different appearances of black. Standing before a large black wall we identify in 80 cases that the blackness of the wall is larger than that of the scale, so we get $(80 + 20i) = 100 \cdot (4/5 + 1/5i)$ (the basis real is here $m = 100$). By applying the Shannon formula on the alternative norm $(4/5 + 1/5i)$ we get again a point on the Shannon curve. The identity $(1/2 + 1/2i)$ indicates here a form of grey. So the identity of black is not black by itself it is grey since grey presents at its one alternativality black and as its other white. In this sense each scale is a set of complex alternatives and therefore a function of knowledge. By this example we see that we have to free ourselves from seeing in the Shannon curve only a representation of statistics.

With this background we can interpret the Shannon curve (right side Figure 9) as the "informative outcome" of complex alternatives. We name the result of applying the Shannon formula on a complex alternative the human potential H and measure it in the unit hbit (human bit). For $\lambda_A = \lambda_E$ we get $H = 1$, which is the maximum of the human potential and which indicates a found identity. The difference ∇ (Nabla) between this maximum and its actual value H is: $\nabla = H_{max} - H$. It indicates the "difference to identity" and shows how much we have to change the world (to "innovate") for getting a new identity. Therefore ∇ is also named innovation impulse (see below).

Entropy and Knowledge

It is shown how the second law of thermodynamics, the fundamental law of the increase of entropy S is influenced by knowledge.

We use the expression in Formula 2, line 8: $T = M / H$ (with $M = m$). M is the number of repeated measures (counts). Since each measure needs energy, M determines the needed energy: $E(M)$. We can interpret T as energy per alternativality (or identity): $T = E(M) / H$. For example knowledge is able to manipulate the natural

flow of water in a way that it turns the wheel of a water mill. Therefore knowledge identifies an identity between the down movement of free running water and its alternative down movement at the one side of a wheel. The smaller this identity is the more water is not used alternatively, the smaller is H the larger is the innovation impulse ∇ , the more we can change the world (innovate) for fulfilling that identity. We get the minimal T if knowledge has found an identity ($H_{\max} = 1$), therefore we get the numeral result $T = E(M)$. That means this form of temperature increases with the repeating of produced identities (e. g. repeating of measures as well as repeating of the turns of the water mill). In our example the water mill slows down the speed of the water stronger than it happens without the water mill. If S_p is the observable increase of the physical entropy and S_K that increase of entropy caused by knowledge, we can write: $S_K > S_p$. We can summarise: knowledge changes the world in a way that it accelerates the natural increase of entropy. This has been known to physics also up to now. The novelty is that we can formalize this and can derive that the largest effect is given if knowledge identifies identities.

A further operable knowledge feature is shown in Formula 2, line 8 by the expression $T = M / H$ (with $M = m$), which is named knowledge temperature. With our experience we interpret M as the number of repeated measures (counts). So this quotient is a measure of how "intensively present" the human potential H is, which means how often we have counted or decided. In the case of the dice it is 130 times. T is formally identical to the physical temperature (as H is comparable to the physical entropy).

Money Added Value

In the following we use in Figure 3 a TH-Diagram for applying physical concepts of thermodynamics to complex alternatives. We derive for the first time how money depends on knowledge features.

We can compose k -dimensional vectors of k complex alternatives \underline{m}_k , which will present operable knowledge features. If we use human skills and abilities as its components and money values for the m_{Ak} , m_{Ek} and if we present these vectors in a 2-dimensional structure as shown in Figure 10, page 10, symbolised by Q_A , Q_B we name it a Q-Distribution. Q-Distributions are specific economic knowledge functions. In (Kreft, 2003) is explained in detail how such Q-Distributions are established in companies. We give the name 'constituents' to the elements on the x -axis (the vector base). So, by using the Shannon curve in Figure 9 we have analysed a Q-Distribution with one constituent and we find all the derived results also on larger Q-Distributions. That is shown for the relation between H , ∇ in the line 1 of the formula in Figure 10. In line 2 is shown the extended Shannon formula for Q-Distributions, which is a sum of the elements of line 4 of Formula 2. The result H represents the human potential of a person who possesses the skills and abilities presented in its Q-Distribution. Line 3 shows that the maximal human potential H_{\max} is one unit larger than the numerical value of its usual Shannon information: $H_{\max} = H_S + 1$. We

get H_{\max} for identical applicative and interpretative contributions ($\lambda_{AK} = \lambda_{EK}$, see Q_A), whereby H_S is the pure Shannon information which presents the smallest informal contribution of a Q-Distribution when it is independent of its inner structure. That means only its outer structure is of importance. If the outer appearance is more even H_S becomes larger and otherwise it decreases. So each human potential contains by its Shannon information H_S a part which is related to its outer appearance. This is in accordance with the hierarchical relation between information and knowledge shown by Figure 1. In contrast the innovation impulse $\nabla = H_{\max} - H$ reflects the inner situation of Q-Distributions. ∇ is the higher the more the inner structure of the Q-Distribution is different to its outer appearance (see dotted lines in Q_A , Q_B). So, in Q_B the innovation impulse ∇ is larger than in Q_A . ∇ is like a distance to identity. ∇ is in any case in the range: $0 \leq \nabla \leq 1$. If its value is nearer to 1 we are near to identity T is proportional to M in which are summed up all the money values m of the Q-Distribution. The unit of T is money per human bit. The larger that T is, the more that one human bit is worth. Since H depends also on the inner structure of a Q-Distribution, it follows that T increases with the innovation impulse ∇ .

$$\begin{aligned}
 1: \quad & \Delta M = M_2 - M_1 = T_2 H_2 - M_1 = T_1' H_2 - M_1 \quad ; \quad \text{with} \quad T_2 = T_1' \\
 2: \quad & \Delta M = \frac{M_1}{H_1'} H_2 - M_1 = \frac{M_1 H_2 - M_1 H_1'}{H_1'} \quad ; \quad \text{with:} \quad \nabla = H_1 - H_1' \\
 3: \quad & \Delta M H_1' = M_1 H_2 - M_1 H_1' = M_1 (H_1 + \Delta H) - M_1 H_1' \\
 4: \quad & \Delta M (H_1 - \nabla) = M_1 (H_1 + \Delta H) - M_1 (H_1 + \nabla) \quad \text{with:} \quad \nabla = H_1 - H_1' \\
 5: \quad & \Delta M (H_S - \nabla) = M_1 (\nabla + \Delta H) \\
 6: \quad & \frac{\Delta M}{M} = \frac{\nabla + \Delta H}{H - \nabla}
 \end{aligned}$$

Formula 3: Money added values depending on operable knowledge

Each hyperbola branch of Figure 3 shows all the possible combinations of the T , H values of a Q-Distributions with fixed M . The "move" from the M_1 -curve to the M_2 -curve is mathematically executed in Figure 11. There we start in line 1 with the condition at point 1 of Figure 11, pass point 2 and reach by line 6 at point 3 of Figure 11. The important result in line 6 is that the formula presents on its left side the money added value $\Delta M / M$ and at the right side only knowledge features. Thereby we have determined for the first time how money values depend on knowledge. Because the innovation impulse ∇ appears positive in the counter of the ratio and negative in the nominator it dominates the outcome of $\Delta M / M$. Above we have shown that the innovation impulse ∇ is "like a distance to identity". From Figure 11 we see that ∇ shifts the $H_1 -$ value to the left, that means the temperature increases and we lose identities $\lambda_{AK} = \lambda_{EK}$. The move between point 1 and point 2 follows from the change of the inner appearance of a Q-Distribution, that is visualised by a change from Q_A to that of Q_B (see Figure 10). The step from point 2 to point 3 is done on a constant temperature level T_2 , whereby we come to a new money value $M + \Delta M$ on which identity is again reached, since we have H_2 always counted in a non reduced

form. Our move means, we have observed a non-identity on a lower level and found on a higher evaluated level identity again.

Related to our above example of the three trees we know on a higher level why trees have to show on a lower level their typical non-identities. We see from that higher level more what is "tree-like". The value ΔH indicates in the formula an increase in human potential which enlarges in all circumstances the money added value. The more we learn the larger is the possible effect. The only term which reduces the left side is the total amount of human potential H in the nominator of the formula. The higher H the more constituents are in a Q-Distribution the more complicate it is to find a new identity between all that constituents again on a higher level of $H + \Delta H$. If we start on a low levelled human potential H it is simpler to create additional values. This is what we can observe in modern economies. The higher the knowledge level (the higher H) the more complicated it is to find a specific effect (identities) which produces money added values.

Since on the y-axis of a Q-Distribution appear money values there is implicitly introduced the future aspect of knowledge by the specific features of money. For example, we get money amounts for brought efforts (products, working hours, services, help etc.). This relation to past is accompanied by one to future, since we can buy in the future different things which are always evaluated by the same amount of money. Supply and demand which determine in market economies prices reflect the knowledge effect behind money. We can see money as the by knowledge evaluated relation between past and future. So, money by itself is a carrier of knowledge functions. From the explanation of innovation we know that knowledge functions have also an inner structure, which evaluates the applicative and the interpretative aspects of knowledge.

AGENTS CONCEPTS AND KNOWLEDGE FUNCTIONS

One of the important development of the concept of economic agents is the emergence of economic features by the autonomous action of agents. We can see agents as program constructs which develop their environments in a preset of rules. From this development over time without further intervention of the modeller (Tessfatsion, 2001) shall arise economic features. If we assume that one essential feature of real economics is knowledge we have to ask how program constructs can establish knowledge. This has been for a long time up to now a not answered question of the theory of automata.

Considering especially the above analyse in the chapter "Knowledge and Alternativity", page 8 we have to state here some additional points:

A: Program constructs (like agents) which deal with complex alternatives shall show operable knowledge features.

B: The problem shall be reducible to the finding of the interpretative reals m_{Ek} of given applicative reals m_{Ak} of complex alternatives in an n-dimensional space.

Firstly we demonstrate our result derived in the chapter "Money Added Value", page 12 by a simple example shown in Figure 13, page 15. There we see in the top part from the left to right the development of a Q-Distribution of two constituents to one of three, whereby we assume that the sum M of the constituents is constant. Below are given the formulas for the economic temperature T . The temperature arises between Q_A and Q_B since the variation of the inner structure of Q_B (increase of ∇). In Q_C is added a new constituent in a way that the temperature is identical to that of Q_B . In the lower part are evaluated the new values of the constituents.

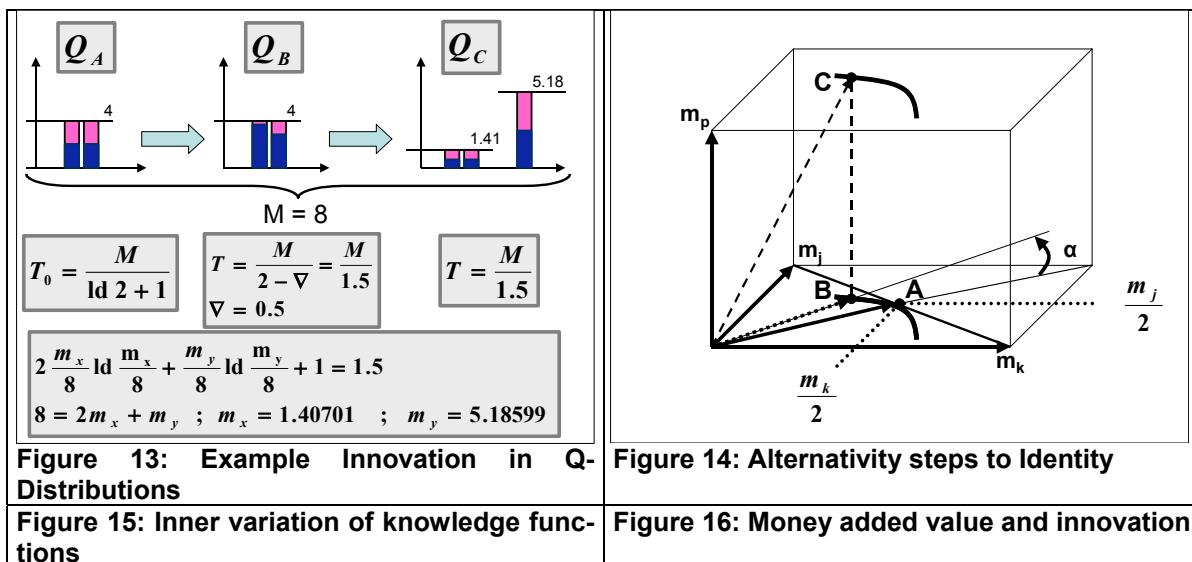

We can interpret the changing from the knowledge function Q_A to that of Q_C as an innovation since there arises a new constituent. Since the outer value M is constant we generate our relation to the outside world by a new combination of constituents. The important point is that inner variation of the constituents of Q_B is eliminated in Q_C . That means we have found a new identity. We reach at this results without the use of complex alternatives.

The following analyse is of more importance for agent concepts. In Figure 14 are demonstrated the principles if we use alternative complex numbers (see explanation Formula 2: Definition of complex alternatives, page 9). In Figure 14 we see a cube of the three constituents m_k, m_j, m_p , which symbolize the constituents of the Q-Distributions in Figure 13. For simplification we do not consider the imaginary unit, we only divide the constituents in two parts. We see by point A that we start with the two equal divided constituents m_k, m_j which thereby are equivalent to Q_A . We shift the vector by variation of the inner parts of Q_A from A to B and get a new vector which is equivalent to the distribution Q_B . Now we look for such a new constituent that the temperature for the combination of the new Q-Distribution Q_C remains constant. We have reached at the point C.

We come to the same result by a transformation of the coordinates.

Usually if we innovate in economics we estimate the value of the new constituent m_p . So we know the estimated $M + \Delta m$ and therefore we know the temperature T .

The curve of constant temperature is shown for the innovated distribution Q_C (in the top of the cube) and its projection into the space of the old distribution is shown in the plane m_k, m_j . So we know on this curve in the plane must be one point A which presents the inner variation of the start distribution established of m_k, m_j .

REFERENCES

Kreft H.D., 2001b, Human potential; How knowledge can be measured, KnowTech 2/3 Nov. Dresden; download: www.humatics.de

Kreft H.D., 2003, Humatics – Theorie der operablen Wissenseigenschaften, Geld und Wissen, Weissensee-Verlag, Berlin, ISBN 3-89998-021-2; download: www.humatics.de

Shannon C.E., 1948, Formula:
www.cm.bell-labs.com/cm/ms/what/shannonday/shannon_1948.pdf

Tesfatsion Leigh, 2003; Agent-Based Computational Economics, Leigh Tesfatsion, Iowa State University, ISU Economics Working Paper No. 1, August 24, 2003; www.econ.iastate.edu/tesfatsi/ ; tesfatsi@iastate.edu

Tesfatsion Leigh, 2001; Economic Agents and Markets as Emergent Phenomena; www.econ.iastate.edu/tesfatsi/; tesfatsi@iastate.edu

H.D. Kreft

REFERENCES

Vitae of H.D. Kreft

Dipl.-Ing. (B.Sc. eng.), born in 1943 in Hamburg, scientist, engineer and inventor, multiple entrepreneur, owner and participant of different companies.

COMPANY HOLDINGS

ADE - Angewandte Digital Elektronik GmbH,
ADE -Applied Digital Electronic Inc. / USA, Paoli
CLM CombiCard License Marketing
Vision Patents AG

More than 70 internationally patented inventions many of which are already being sold as products by well-known companies: Electronic house-door Key Ikontron, Ikon AG, Berlin; POMUX, electr. length measurement System, Max Stegmann Company, Donaueschingen; Chip card patents (Siemens, Gemplus, PAV)

1986. Frankfurt: **Arthur- Fischer- DABEL prize** "Invention and innovation for humankind"

1987. Frankfurt: **Innovation prize of the German Economy** for the non-contact Chip card

Since 1988. Bonn/Berlin: **Member of the Research and Development Committee of the DIHK** (Head of German Commercial Chambers)

1989, Berlin: **Chairman of the association "Free Elections GDR"**, first public presentations on the "fair economy" with representatives of the GDR citizens' movement

1996. Helsinki: **ESCAT- European SmartCard prize**

1997. Darmstadt: **GMD SmartCard prize** of the Society for Mathematics and Data Processing for smart card inventions

1999, Hamburg: Completion of the work **"Humatics"** (operability of knowledge, Thermoeconomics)

1999, Berlin: Awarded the **Federal Service Cross** of the Federal Republic of Germany at an award ceremony by German President Johannes Rau

23. 2. 2001, Wittlingen: Awarded the **Rudolf Diesel Gold Medal** for extraordinary achievements as an inventor at an award ceremony by First Minister Clement

March 2001, Berlin: **Book, Das Humanpotential**, Wissen und Wohlstandswachstum (Human potential, knowledge and prosperity) ISBN 3-89700-142-X, Berlin, VWF Verlag für Wissenschaft und Forschung GmbH

6. Sept. 2001, Helsinki: **Member of Hall of Fame** of ESCAT for latest achievements in the measurement of human knowledge

24. Oct. 2001, Neuss: Awarded the **Prize of Innovation** for exploring the operability of knowledge by Netz innovativer Bürger and Bürgerinnen (network of innovative citizens)

Dec. 2003, Berlin: **Book, Geld und Wissen**, (Money and Knowledge), Weißensee Verlag, ISBN 3-89998-021-2 (www.weissensee-verlag.de)

Further information: www.Hans-Diedrich-Kreft.de and www.humatics.de